

# ENGINEERING DRAWING

## (NSQF)

### 1<sup>st</sup> Year

---

**Common for All Engineering Trades under CTS**

---

**(Not applicable for Draughtsman Trade Group)**

**(For all 1 Year & 2 Year Trades)**



Directorate General of Training

**DIRECTORATE GENERAL OF TRAINING  
MINISTRY OF SKILL DEVELOPMENT & ENTREPRENEURSHIP  
GOVERNMENT OF INDIA**



**NATIONAL INSTRUCTIONAL  
MEDIA INSTITUTE, CHENNAI**

---

Post Box No. 3142, CTI Campus, Guindy, Chennai - 600 032

Copyright Free. Under CC BY License.

## Engineering Drawing (NSQF) - 1<sup>st</sup> Year

Common for all Engineering Trades under CTS (Not applicable for Draughtsman Trade Group)

### Developed & Published by



#### **National Instructional Media Institute**

Post Box No.3142

Guindy, Chennai - 32

INDIA

Email: Chennai-nimi@nic.in

Website: www.nimi.gov.in

#### **Printed by**

National Instructional Media Institute

Chennai - 600 032

First Edition :November 2019

**Rs.170/-**



## FOREWORD

The Government of India has set an ambitious target of imparting skills to 30 crores people, one out of every four Indians, by 2020 to help them secure jobs as part of the National Skills Development Policy. Industrial Training Institutes (ITIs) play a vital role in this process especially in terms of providing skilled manpower. Keeping this in mind, and for providing the current industry relevant skill training to Trainees, ITI syllabus has been recently updated with the help of comprising various stakeholder's viz. Industries, Entrepreneurs, Academicians and representatives from ITIs.

The National Instructional Media Institute (NIMI), Chennai, has now come up with instructional material to suit the revised curriculum for **Engineering Drawing 1<sup>st</sup> Year (For All 1 year & 2 year Trades)** NSQF Common for all engineering trades under CTS will help the trainees to get an international equivalency standard where their skill proficiency and competency will be duly recognized across the globe and this will also increase the scope of recognition of prior learning. NSQF trainees will also get the opportunities to promote life long learning and skill development. I have no doubt that with NSQF the trainers and trainees of ITIs, and all stakeholders will derive maximum benefits from these IMPs and that NIMI's effort will go a long way in improving the quality of Vocational training in the country.

The Executive Director & Staff of NIMI and members of Media Development Committee deserve appreciation for their contribution in bringing out this publication.

Jai Hind

**RAJESH AGGARWAL**

Director General/ Addl. Secretary  
Ministry of Skill Development & Entrepreneurship,  
Government of India.

New Delhi - 110 001

## PREFACE

The National Instructional Media Institute(NIMI) was set up at Chennai, by the Directorate General of Training, Ministry of skill Development and Entrepreneurship, Government of India, with the technical assistance from the Govt of the Federal Republic of Germany with the prime objective of developing and disseminating instructional Material for various trades as per prescribed syllabus and Craftsman Training Programme(CTS) under NSQF levels.

The Instructional materials are developed and produced in the form of Instructional Media Packages (IMPs), consisting of Trade Theory, Trade Practical, Test and Assignment Book, Instructor Guide, Wall charts, Transparencies and other supportive materials. The above material will enable to achieve overall improvement in the standard of training in ITIs.

A national multi-skill programme called SKILL INDIA, was launched by the Government of India, through a Gazette Notification from the Ministry of Finance (Dept of Economic Affairs), Govt of India, dated 27th December 2013, with a view to create opportunities, space and scope for the development of talents of Indian Youth, and to develop those sectors under Skill Development.

The emphasis is to skill the Youth in such a manner to enable them to get employment and also improve Entrepreneurship by providing training, support and guidance for all occupation that were of traditional types. The training programme would be in the lines of International level, so that youths of our Country can get employed within the Country or Overseas employment. The **National Skill Qualification Framework (NSQF)**, anchored at the National Skill Development Agency(NSDA), is a Nationally Integrated Education and competency-based framework, to organize all qualifications according to a series of **levels of Knowledge, Skill and Aptitude**. Under NSQF the learner can acquire the Certification for Competency needed at any level through formal, non-formal or informal learning.

The **Engineering Drawing** 1<sup>st</sup> Year (Comon for All 1 year & 2 year Engineering Trades under CTS) is one of the book developed by the core group members as per the NSQF syllabus.

The **Engineering Drawing** (Common for All 1 year & 2 year Engineering Trades under CTS as per NSQF) 1<sup>st</sup> Year is the outcome of the collective efforts of experts from Field Institutes of DGT, Champion ITI's for each of the Sectors, and also Media Development Committee (**MDC**) members and Staff of **NIMI**. NIMI wishes that the above material will fulfill to satisfy the long needs of the trainees and instructors and shall help the trainees for their Employability in Vocational Training.

NIMI would like to take this opportunity to convey sincere thanks to all the Members and Media Development Committee (MDC) members.

Chennai - 600 032

**R. P. DHINGRA**  
**EXECUTIVE DIRECTOR**



## ACKNOWLEDGEMENT

The National Instructional Media Institute (NIMI) sincerely acknowledge with thanks the co-operation and contribution of the following Media Developers to bring this IMP for the course **Engineering Drawing (1<sup>st</sup> Year (For All 1 year & 2 year Trades))** as per NSQF.

### MEDIA DEVELOPMENT COMMITTEE MEMBERS

Shri. M. Sangara pandian	-	Training Officer (Retd.) CTI, Guindy, Chennai.
Shri. G. Sathiamoorthy	-	Jr. Training Officer (Retd.) Govt I.T.I, DET - Tamilnadu.

### NIMI CO-ORDINATORS

Shri. Nirmalya Nath	-	Deputy General Manager, NIMI, Chennai - 32.
Shri. G. Michael Johny	-	Assistant Manager, NIMI, Chennai - 32.

NIMI records its appreciation of the **Data Entry, CAD, DTP Operators** for their excellent and devoted services in the process of development of this IMP.

NIMI also acknowledges with thanks, the efforts rendered by all other staff who have contributed for the development of this book.

## INTRODUCTION

Theory and procedure along with the related exercises for further practice

This book on theory and procedure along with related exercises contains theoretical information on **1<sup>st</sup> year Engineering drawing** (for engineering trades of 1 year and 2 year) and procedure of drawing/ sketching different exercise for further practice are also available. Wherever required, BIS specification has been used..

Exercise for further practice

The practice exercise is given with Theory and procedure for 1<sup>st</sup> Year book made obsolete as it was felt that, it is very difficult to work in workbook using drawing instruments. It is well known fact that, any drawing is prepared on suitable standard size of drawing sheets only.

The instructor is herewith advised to go through the instructions given below and to follow them in view of imparting much drawing skill in the trainees.

Acquiring the above said ability and doing small drawings is not a simple task. These books will provide a good platform for achieving the said skills.

**Time allotment:**

**Duration of 1<sup>st</sup> Year : 80 Hrs**

Time allotment for each module has been given below. Common to all 1 year and 2 year Engineering Trades.

S.No	Title	Exercise No.	Time allotment
1	Engineering Drawing Introduction	1.1.01 - 1.1.04	1
2	Drawing Instrument	1.2.05 - 1.2.07	1
3	Free hand drawing	1.3.08 - 1.3.14	10
4	Lines	1.4.15 & 1.4.16	2
5	Drawing of Geometrical figures	1.5.17 - 1.5.21	8
6	Lettering & Numbering	1.6.22	6
7	Dimensioning and its Practice	1.7.23 - 1.7.25	4
8	Sizes and layout of drawing sheets	1.8.26	2
9	Method of presentation of Engineering Drawing	1.9.27 & 1.9.28	2
10	Symbolic representation – different symbols used in the trades	1.10.29 - 1.10.33	6
11	Projections	1.11.34 - 1.11.37	15
12	Orthographic projection from isometric projection	1.12.38	15
13	Reading of fabrication drawing	1.13.39	8
			80 Hrs

### Instructions to the Instructors

It is suggested to get the drawing prepared on A4/A3 sheets preferably on only one side. If separate table and chair facility is available for every trainee then it is preferred to use A3 sheets and if the drawing hall is provided with desks then A4 sheets may be used. However while preparing bigger drawings on A4 sheets suitable reduction scale to be used or multiple sheets may be used for detailed and assembly drawings.

First the border and the title block to be drawn only for the first sheet of the chapter. Eg. for conical sections only first sheet will have the title block whereas the rest of the sheets of that chapter will have only borders.

Serial number of sheet and total no. of sheets to be mentioned on each sheet.

The completed sheet to be punched and filled in a box file/ suitable files and preserved by the trainees carefully after the approval of instructors, VPS and Principals of the Institute.

The file may be referred by the authority before granting the internal marks at the end of 1<sup>st</sup> year.

## CONTENTS

Exercise No.	Title of the Exercise	Page No.
	<b>Engineering Drawing Introduction</b>	
1.1.01	Introduction to engineering drawing	1
1.1.02	Conventions	4
1.1.03	Views of engineering drawing sheets	5
1.1.04	Method of folding of printed drawing sheets as per BIS SP: 46-2003	7
	<b>Drawing Instrument</b>	
1.2.05	Drawing instruments - Drawing board, T - square, drafter (drafting machine)	9
1.2.06	Drawing instruments - Setsquares, protractor and scale	11
1.2.07	Drawing Instruments box and pencils	12
	<b>Free hand drawing</b>	
1.3.08	Free hand drawing of lines	15
1.3.09	Free hand drawing - Polygons and ellipse	20
1.3.10	Free hand drawing of geometrical figures and block with dimension	24
1.3.11	Free hand drawing of transferring measurement from the given object	25
1.3.12	Free hand drawing of solid figures, cubes, cuboids, cone, prism, pyramid, frustum of cone with dimensions	29
1.3.13	Freehand drawing of hand tools and measuring tools used in common trades	32
1.3.14	Freehand drawing of simple fasteners (bolts, nuts and rivets etc.) trade related sketches	49
	<b>Lines</b>	
1.4.15	Lines - Definition, types and applications in drawing as per BIS: 46-2003 and classification of lines	51
1.4.16	Lines - Drawing lines of given length (straight, curved), drawing of parallel lines, perpendicular line and methods of division of line segment	55
	<b>Drawing of Geometrical figures</b>	
1.5.17	Drawing of geometrical figures - Definition, nomenclature and practice of angle, measurement and its types, and types of angle and triangle	59
1.5.18	Drawing of geometrical figures - Method of bisecting practice of angles and triangles	61
1.5.19	Geometrical figures - Square, rectangle, rhombus, parallelogram, circle and its elements	66
1.5.20	Drawing of geometrical figures - Practice of square, rectangle, parallelogram, rhombus and circle	68
1.5.21	Drawing of geometrical figures - Different polygons and their values of included angles. Inscribed and circumscribed polygons	74
	<b>Lettering &amp; Numbering</b>	
1.6.22	Lettering and numbering - Single stroke, double stroke and inclined	77

Exercise No.	Title of the Exercise	Page No.
	<b>Dimensioning and its Practice</b>	
1.7.23	Dimensioning - Definition, and its types, types of arrow heads and leaderline with text	85
1.7.24	Dimensioning and its practice - Methods of dimensions and position of dimensioning (aligned, unidirectional)	87
1.7.25	Symbols preceding the value of dimension and dimensional tolerance	97
	<b>Sizes and layout of drawing sheets</b>	
1.8.26	Sizes and layout of drawing sheets - Selection of sizes, title Block, its position & content and item reference on drawing sheet (item list)	100
	<b>Method of presentation of Engineering Drawing</b>	
1.9.27	Method of presentation of engineering drawing - Pictorial view and isometric view	104
1.9.28	Method of presentation of engineering drawing - Orthographic views	114
	<b>Symbolic representation – different symbols used in the trades</b>	
1.10.29	Symbolic representation - different symbols used in the trades - Fastener (bolts, nuts and rivets)	116
1.10.30	Symbolic representation of bars and profile sections	119
1.10.31	Symbolic representation of weld, brazed and soldered joints	120
1.10.32	Symbolic representation of electrical and electronic elements	122
1.10.33	Symbolic representation of piping joints and fittings	126
	<b>Projections</b>	
1.11.34	Projections - Concept of axes plane and quadrant	128
1.11.35	Projections - Orthographic projection	131
1.11.36	Projection - Method of 1st angle and 3rd angle projections (Definition and difference)	136
1.11.37	Projection - Symbol of 1st angle and 3rd angle projection as per IS specification	138
	<b>Orthographic projection from isometric projection</b>	
1.12.38	Drawing of orthographic projection from isometric projection	139
	<b>Reading of fabrication drawing</b>	
1.13.39	Reading of fabrication drawing for sheet metal worker trade	143

## LEARNING / ASSESSABLE OUTCOME

On completion of this book you shall be able to

- **Read and apply engineering drawing for different application in the field of work.**

# SYLLABUS

**1<sup>st</sup> Year**

**Common for all Engineering trades under CTS  
(Not applicable for Draughtsman trade Group)**

**Duration: One Year**

S.no.	Syllabus	Time in Hrs
<b>I</b>	<p><b>Engineering Drawing – Introduction</b></p> <p>Introduction to Engineering Drawing and Drawing Instruments –</p> <ol style="list-style-type: none"> <li>1 Conventions</li> <li>2 Viewing of engineering drawing sheets.</li> <li>3 Method of Folding of printed Drawing sheet as per BIS SP: 46-2003</li> </ol>	<b>1</b>
<b>II</b>	<p><b>Drawing Instrument</b></p> <ol style="list-style-type: none"> <li>1 Drawing board, T-square, Drafter (Drafting M/c), Set squares, Protector, Drawing Instrument Box (Compass, Dividers, Scale, Diagonal Scales etc.), pencils of different grades, Drawing pins/ Clips.</li> </ol>	<b>1</b>
<b>III</b>	<p><b>Free hand drawing of –</b></p> <ol style="list-style-type: none"> <li>1 Lines, polygons, ellipse etc.</li> <li>2 Geometrical figures and blocks with dimension</li> <li>3 Transferring measurement from the given object to the free hand sketches.</li> <li>4 Solid objects - Cube, Cuboids, Cone, Prism, Pyramid, Frustum of Cone with dimensions.</li> <li>5 Free hand drawing of hand tools and measuring tools, simple fasteners (nuts, bolts, rivets etc.) trade related sketches</li> </ol>	<b>10</b>
<b>IV</b>	<p><b>Lines</b></p> <ol style="list-style-type: none"> <li>1 Definition, types and applications in drawing as per BIS: 46-2003</li> <li>2 Classification of lines (Hidden, centre, construction, extension, Dimension, Section)</li> <li>3 Drawing lines of given length (Straight, curved)</li> <li>4 Drawing of parallel lines, perpendicular line</li> <li>5 Methods of Division of line segment</li> </ol>	<b>2</b>
<b>V</b>	<p><b>Drawing of Geometrical figures:</b></p> <p>Definition, nomenclature and practice of –</p> <ol style="list-style-type: none"> <li>1 Angle: Measurement and its types, method of bisecting.</li> <li>2 Triangle: different types</li> <li>3 Rectangle, Square, Rhombus, Parallelogram.</li> <li>4 Circle and its elements</li> <li>5 Different polygon and their values of included angles. Inscribed and circumscribed polygons</li> </ol>	<b>8</b>

S.no.	Syllabus	Time in Hrs
<b>VI</b>	<b>Lettering &amp; Numbering</b> 1 Single Stroke, Double Stroke, Inclined.	<b>6</b>
<b>VII</b>	<b>Dimensioning and its Practice</b> 1 Definition, types and methods of dimensioning (functional, non-functional and auxiliary) 2 Position of dimensioning (Unidirectional, Aligned) 3 Types of arrowhead 4 Leader line with text 5 Symbols preceding the value of dimension and dimensional tolerance.	<b>4</b>
<b>VIII</b>	<b>Sizes and layout of drawing sheets</b> 1 Selection of sizes 2 Title Block, its position and content 3 Item Reference on Drawing Sheet (Item list)	<b>2</b>
<b>IX</b>	<b>Method of presentation of Engineering Drawing</b> 1 Pictorial View 2 Orthographic View 3 Isometric View	<b>2</b>
<b>X</b>	<b>Symbolic representation – different symbols used in the trades</b> 1 Fastener (Rivets, Bolts and Nuts) 2 Bars and profile sections 3 Weld, Brazed and soldered joints 4 Electrical and electronics element 5 Piping joints and fitting	<b>6</b>
<b>XI</b>	<b>Projections</b> 1 Concept of axes plane and quadrant 2 Orthographic projections 3 Method of first angle and third angle projections (definition and difference) 4 Symbol of 1 <sup>st</sup> angle and 3 <sup>rd</sup> angle projection.	<b>15</b>
<b>XII</b>	<b>Orthographic projection from isometric projection</b>	<b>15</b>
<b>XIII</b>	<b>Reading of fabrication drawing</b>	<b>8</b>
	<b>Total</b>	<b>80</b>

---

**Introduction to engineering drawing**

---

**Communication**

There are many different ways of communicating ideas, informations, instructions, requests, etc. They can be transmitted by signs or gestures, by word of mouth, in writing, or graphically. In an industrial context the graphical method is commonly used, communication being achieved by means of engineering drawings.

If oral and written communication only were used when dealing with technical matters, misunderstandings could arise, particularly in relation to shape and size. The lack of a universal spoken language makes communication and understanding even more difficult because of the necessity to translate both words and meaning from one language to another.

However, the universally accepted methods used in graphical communication through engineering drawings eliminate many of these difficulties and make it possible for drawing prepared by a British designer to be correctly interpreted or “read” by, for example, his German, French or Dutch counterpart.

Equally important, the components shown on the drawings could be made by suitably skilled craftsmen of any nationality provided they can “read” an engineering drawing.

Conventionally prepared engineering drawing provide the main means of communication between the “ideas” men (the designers and draughtsman) and the craftsmen (machinists, fitters, assemblers, etc.). For the communication to be effective, everyone concerned must interpret the drawing in the same way. Only then will the finished product be exactly as the designer envisages it.

To ensure uniformity of interpretation the British Standards Institution have prepared a booklet entitled BS 308:1972, Engineering Drawing Practice. Now in three parts, this publication recommends the methods which should be adopted for the preparation of drawing used in the engineering industry.

The standards and conventions in most common use and hence those required for a basic understanding of Engineering Drawing are illustrated and explained in this book.

**Limitations of sign language**

- 1 Information/feelings cannot be conveyed effectively
- 2 Chances of misunderstanding the information / feelings
- 3 Both the communicator and the receiver to be present at the same place

**Limitations of graphical language**

- 1 Information /feelings can be conveyed effectively but still there are chances for imagination (communication gap).
- 2 Viewer may image anything in his mind due to the absence of written language.

**Limitations of vocal language**

- 1 Speaker and the listener should be aware of same language.
- 2 Still there are chances of misunderstanding due to communication gap.
- 3 Some languages (without alphabets) are existing on tongues only.
- 4 Written language can also be misunderstood as each and every word gives more than one meaning.

**Limitations of computer language**

- 1 Used only by computer programmers.
- 2 Cannot be used for general communication.

**Conclusion**

Effective communication is possible when graphical language is supported by written language/vocal language and vice versa.

Engineering drawing is a language which uses both graphical language and written language for effective communication

Eg. In FM radios jockeys use vocal language

Eg. News papers use graphical language + Written language

Eg. In television they use Graphical language (motion/ still pictures) + written language + vocal language

For Effective communication

**Engineering drawing is a graphical language which also uses written language for effective communication**

**Importance of Engineering Drawing**

The economical success of any country is mainly depended on its industrial development. Due to the globalization any industry of our country expected to be of global market standard. Due to the above said reason our Indian product required to be of very high quality with respect to size of dimension, fit, tolerance and finish etc.



To produce a best standard product all the technical personnel (Engineers to Craftsman) in an industry must have a sound knowledge in engineering drawing because engineering drawing is the language of engineers. Engineering drawing is a universal language. Different types of lines are its alphabets. Technical personnel in any industry including craftsmen are expected to communicate anything concerning a part or a component by drawings involving lines, symbols, convention and abbreviations etc.

With our spoken languages it is impossible to express the details of a job or a product. Engineering drawing knowledge and practice are must for designing or producing a component or part. Even a small mistake in the drawing may reflect very badly in the product. Therefore reading and doing engineering drawing are very much essential for craftsmen and engineers

A drawing is a graphical representation of an object, or part of it, and is the result of creative thought by an engineer or technician. When one person sketches a rough map in giving direction to another, this is graphic communication. Graphic communication involves using visual materials to relate ideas. Drawings, photographs, slides, transparencies, and sketches are all forms of graphic communication. Any medium that uses a graphic image to aid in conveying a message, instructions, or an idea is involved in graphic communication.

One of the most widely used forms of graphic communication is the drawing. Technically, it can be defined as **"a graphic representation of an idea, a concept or an entity which actually or potentially exists in life"**

Drawing is one of the oldest forms of communicating, dating back even farther than verbal communication. The drawing itself is a way communicating necessary information about an abstract, such as an idea or concept or a graphic representation of some real entity, such as a machine part, house or tools. There are two basic types of drawings: Artistic and Technical drawings.

## Technical drawings

Technical drawings allows efficient communication among engineers and can be kept as a record of the planning process. Since a picture is worth a thousand words, a technical drawing is a much more effective tool for engineers than a written plan.

The technical drawing, on the other hand is not subtle, or abstract. It does not require an understanding of its creator, only on understanding of technical drawings. A technical drawing is a means of clearly and concisely communicating all of the information necessary to transform an idea or a concept in to reality. Therefore, a technical drawing often contains more than just a graphic representation of its subject. It also contains dimensions, notes and specifications.

### Fields of use:

Technical drawing is the preferred method of drafting in all engineering fields, including, but not limited to, civil engineering, electrical engineering, mechanical engineering and architecture.

### Purpose of studying engineering drawing:

- 1 To develop the ability to produce simple engineering drawing and sketches based on current practice
- 2 To develop the skills to read manufacturing and construction drawings used in industry.
- 3 To develop a working knowledge of the layout of plant and equipment.
- 4 To develop skills in abstracting information from calculation sheets and schematic diagrams to produce working drawings for manufacturers, installers and fabricators.

### Main types of Engineering drawing:

Regardless of branch of engineering the engineering drawing is used. However based on the major engineering branches, engineering drawing can be classified as follows: (Fig 1)

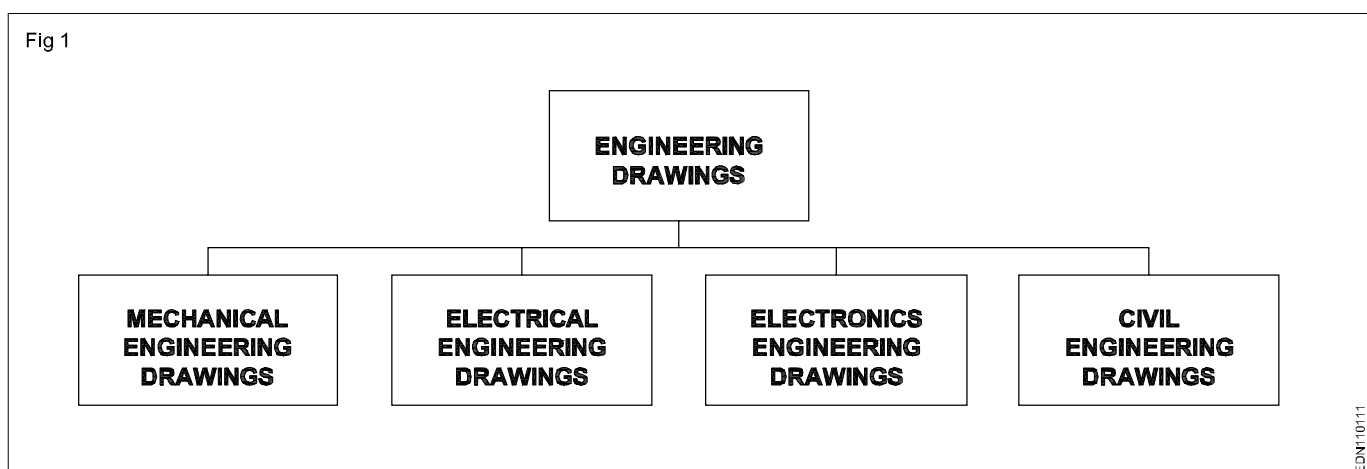



## Mechanical engineering drawings:

Some examples of mechanical engineering drawings are part and assembly drawings, riveted joints, welded joints, fabrication drawings, pneumatics and hydraulics drawings, pipeline diagrams, keys coupling drawings etc. (Fig 2)

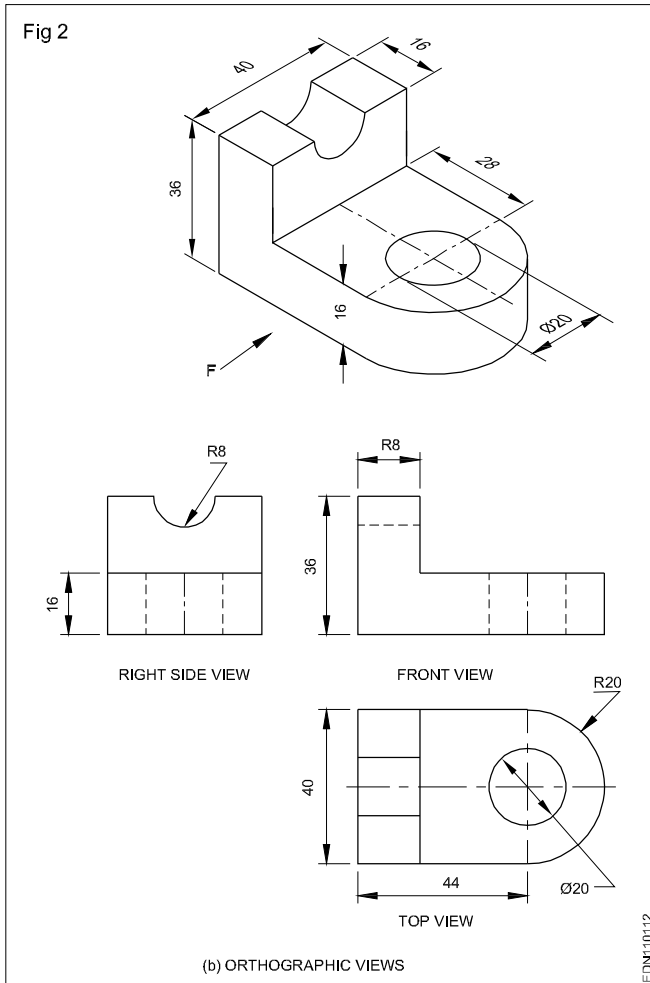

Answer the following questions.

- 1 Discuss the different types of drawings?
- 2 Explain the different applications of technical drawing?
- 3 What is graphical communications?

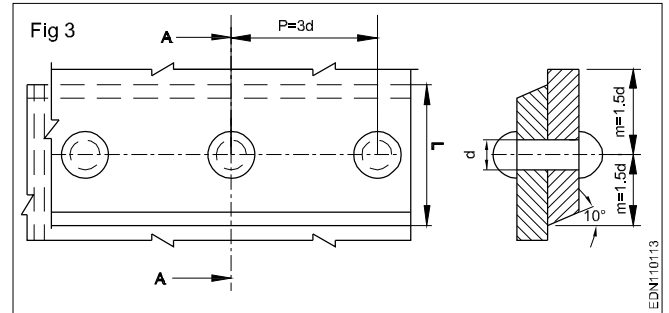

## Electrical Engineering drawings

Wiring diagrams of home and industries, circuit diagrams, electrical installation drawings etc.

Example

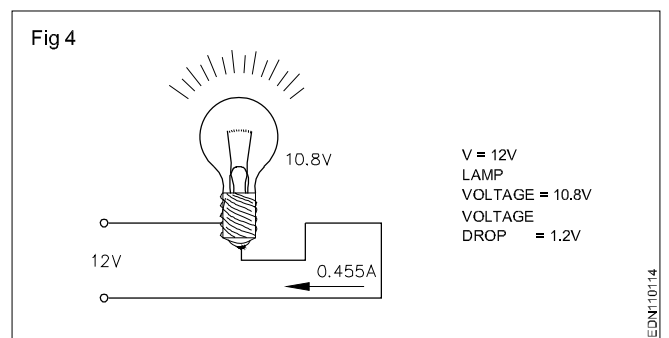

The voltage supply to a filament lamp is 10.8V. The voltage should be 12V. (Fig 4)

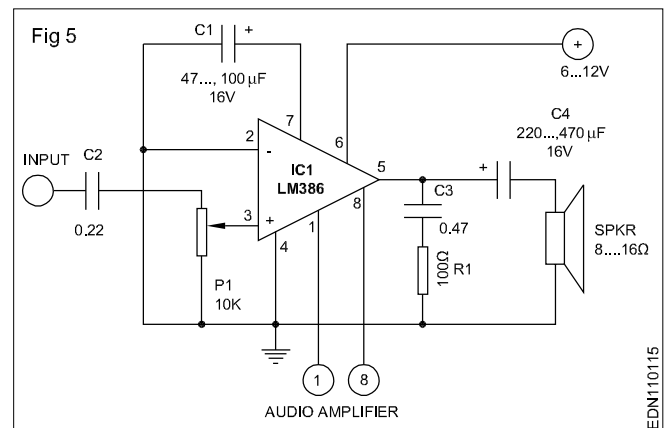

## Audio amplifier (Fig 5)

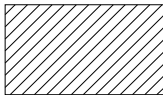

**Conventions**

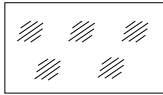
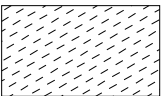
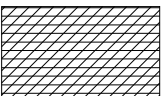
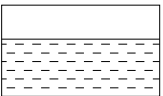
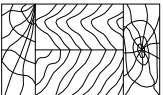
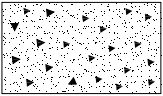
TYPE	CONVENTION	MATERIALS
Metals		Steel, Cast Iron, Copper and its Alloys, Aluminium and its alloy, etc
		Lead, Zinc Tin White-metal, etc.
Glass		Glass
Packing and Insulating materials		Porcelain, Stoneware, Marble, Slate etc
		Asbestos, Fibre, Felt, Synthetic resin, Products, Paper, Cork, Linoleum, Rubber, Leather, Wax, insulating & Filling Materials etc
Liquid		Water, Oil, Petrol, Kerosene etc
Wood		Wood, Plywood etc
Concrete		Concrete

**Views of engineering drawing sheets**

**Drawing paper:** These are of two types:

- Hand-made paper
- Mill-made paper

Hand-made papers have rough surfaces, pale in colour and not used for regular work, but meant for charts.

Mill-made papers are most commonly used for regular work, and are available in different sizes and rolls. They are specified by their weight in kg per ream or density in grams per square meter.

**Size of drawing sheets** (in mm): While working or handling, the papers are liable to tear on the edges. So slightly large size (untrimmed) sheets are preferred. They are trimmed afterwards. IS:10811:1983 lays down such as designation of preferred trimmed and untrimmed sizes.

The basic principle involved in arriving at the sizes of the drawing paper is as under. The area of the biggest size (A0) is  $1\text{m}^2$  and its breadth and length are in the ratio  $1:\sqrt{2}$ . Let  $x$  and  $y$  are the sides of the paper. The surface area of A0 is  $1\text{m}^2$ , then the sides are  $x = 0.841\text{ m}$  and  $y = 1.189\text{ m}$ . (Fig1)

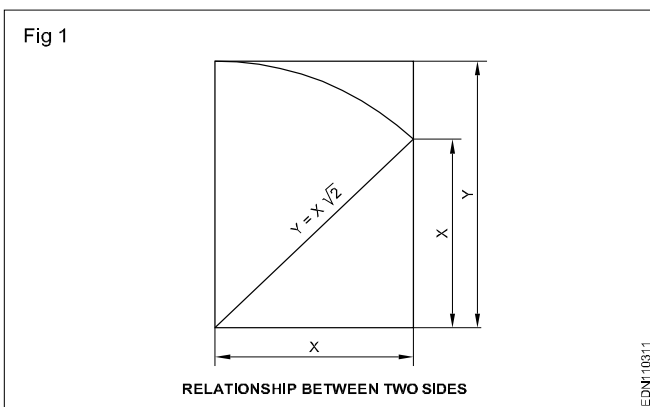

Two series of successive sizes are obtained by either halving or doubling along the length. The area of the successive sizes are in the ratio of 1:2.

**Designation of sheets:** The drawing sheets are designated by symbols such as A0, A1, A2, A3, A4 and A5. A0 being the largest. Table 1 below gives the length and breadth of the above sizes of sheets. (Trimmed and untrimmed)

The relationship between two sides is same as that of a side of a square and its diagonal.

TABLE 1

Designation	Trimmed size	Untrimmed size
A0	841 x 1189	880 x 1230
A1	594 x 841	625 x 880
A2	420 x 594	450 x 625
A3	297 x 420	330 x 450
A4	210 x 297	240 x 330
A5	148 x 210	165 x 240

For drawings which cannot be accommodated in above sheets, elongated series are used. Elongated series are designated by symbols A1 x 3; A2 x 4 etc.

Special elongated series increasing its widths, double, treble etc. are designated as follows A3 x 3, A3 x 4, A4 x 3, A4 x 4, A4 x 5. Please refer Table 2

TABLE 2

**Special elongated series**

Designation	Size
A3 x 3	420 x 891
A3 x 4	420 x 1189
A4 x 3	297 x 630
A4 x 4	297 x 841
A4 x 5	297 x 1051

**Exceptional elongated series**

Designation	Size
A0 x 2	1189 x 1682
A0 x 3	1189 x 2523
A1 x 3	841 x 1783
A1 x 4	841 x 2378
A2 x 3	594 x 1261
A2 x 4	594 x 1682
A2 x 5	594 x 2102
A3 x 5	420 x 1486
A3 x 6	420 x 1783
A3 x 7	420 x 2080
A4 x 6	297 x 1261
A4 x 7	297 x 1471
A4 x 8	297 x 1682
A4 x 9	297 x 1892

A4 x 3 means the length of A4 size is retained and the other side is 3 times the width of A4.

$$A4 \times 3 = 297 \times 630 \text{ (} 210 \times 3 \text{)}$$

Fig 2 & 3 shows how the sheet sizes are formed by halving/doubling and similarity of format.

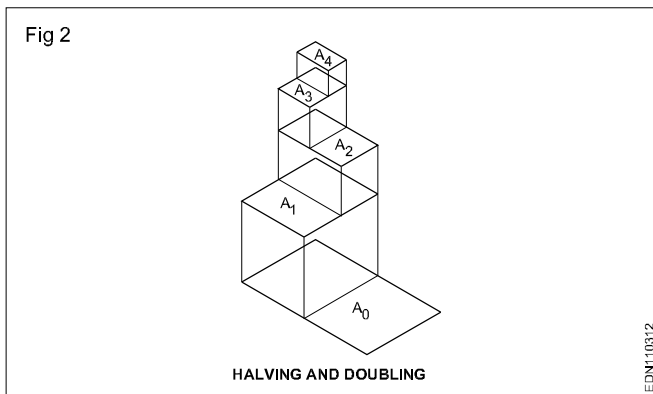

White drawing papers which do not become yellow on exposure to atmosphere are used for finished drawings, maps, charts and drawings for photographic reproductions. For pencil layouts and working drawings, cream colour papers are best suited.

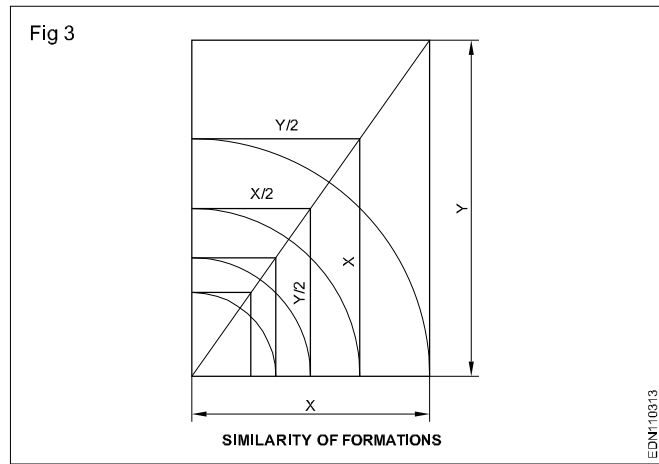

**Quality drawing paper:** The drawing papers should have sufficient teeth or grain to take the pencil lines and withstand repeated erasing.

A backing paper is to be placed on the drawing board before fixing drawing/tracing paper, to get uniform lines. Before starting the drawing, the layout should be drawn. (Ref: IS:10711)

**Method of folding of printed drawing sheets as per BIS SP: 46-2003**

**Method of folding of printed drawing sheets as per BIS SP: 46-2003**

When drawings sheets are in more numbers, they have to be folded and kept in order to save the trace required for preserving them (Fig 1).

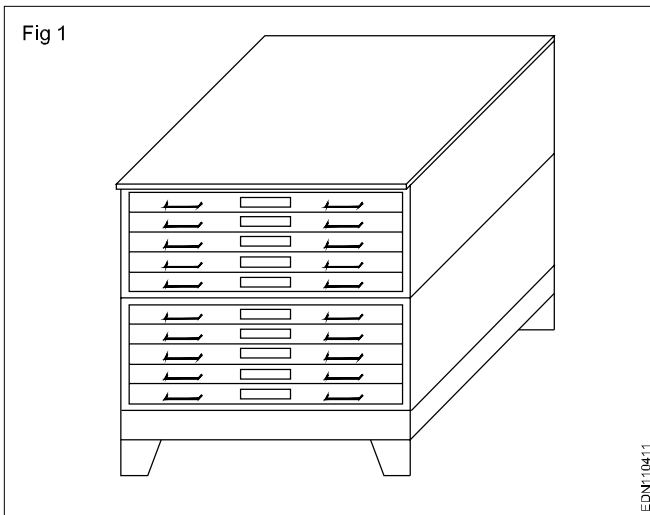

When the drawings are to be released to shop floor for reference during manufacturing of a component

**Applicability**

Folding of drawings applies to only the drawings which are released for shop floor for manufacturing of components / reference. Original drawings will never be taken out of drawing office and they should be kept under safe custody. Drawings which are prepared on tracing sheets/ transparencies like cloth, polymer, acrylic polymer transparencies should never be folded. They should be kept in polythene folders and kept in filing cabinets. Sometimes the blue prints/photo copies of drawings which are released to shop floor are also laminated for extending their life.

**Requirement**

While folding the drawings following care to be taken.

It is required to fold the drawings such that, they should not get defaced damaged.

Drawing sheet to be folded such that the title block is easily visible to retrieve it and keeping it back.

The following is the method of folding printed drawing sheets as recommended by BIS (Fig 2)

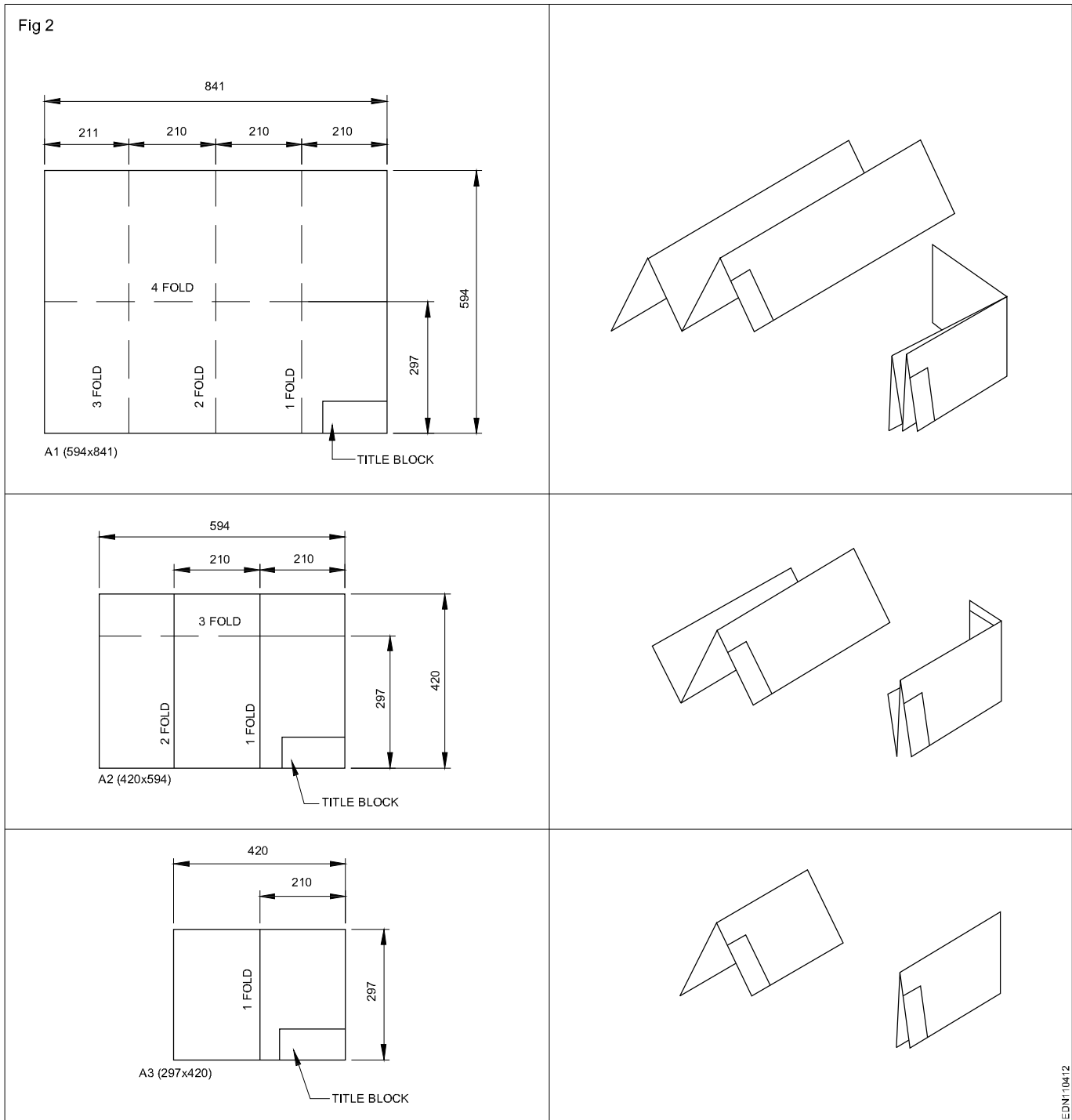

**Drawing instruments - Drawing board, T - square, drafter (drafting machine)**

The following are the commonly used equipment in a drawing office.

**Drawing board** (Fig 1): Drawing board is one of the main equipment of Draughtsman. It is used for supporting the drawing paper/tracing paper for making drawings. It is made of well seasoned wood strips of about 25 mm thick or masonite, free from knots and warping. It should be softer enough to allow insertion and removal of drawing pins. Two battens are fastened to the board by screws, in slotted joints. They prevent warping and at the same time permit expansion and contraction of the strips due to the change of moisture in the atmosphere.

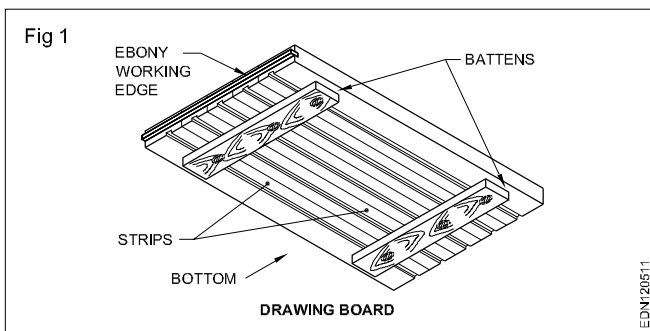

One of the shorter edges of the drawing board, is provided with an “ebony edge” (hard wood) fitted perfectly straight.

Standard drawing boards are designated as follows as per IS:1444-1989.

Sl. No.	Designation	Size (mm)
1	D0	1500 x 1000 x 25
2	D1	1000 x 700 x 25
3	D2	700 x 500 x 15
4	D3	500 x 350 x 15

The working edge (ebony) must be straight.

Now-a-days the drawing boards are available with laminated surfaces. The flatness can be checked by placing a straight edge on its surface. If no light passes between them, the surface is perfectly flat.

**‘T’ Square:** It is of ‘T’ shape, made of well seasoned wood. It has two parts., head and blade. One of the edge of the blade is the working edge. The blade is screwed to this head such that the working edge is at right angle to head. (Fig 2a)

The standard ‘T’ square are designated as follows with dimensions shown in mm; as per IS:1360-1989.

Sl. No.	Designation	Blade length
1	T0	1500
2	T1	1000
3	T2	700
4	T3	500

The ‘T’ square is used with its head against the ebony edge of the drawing board to draw horizontal lines, parallel lines and to guide/hold the setsquares, stencils etc.

Fig 2b shows how the ‘T’ square is used.

‘T’ square should never be used as a hammer or as guide for trimming papers

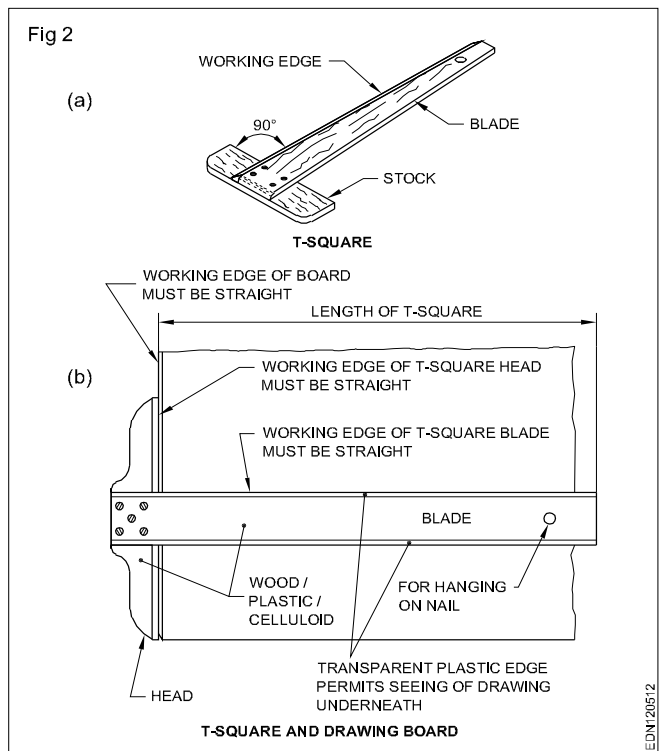

**Drafting in the machine** (Fig 3): It serves the functions of a Tee square, set square, protractor and scale. They come in different sizes and a pattern called ‘Pantagraph’ type. It is fitted on the top left side, edge of the drafting board, mounted on an adjustable frame or table. It requires large area of working place. The angle of the drafting board can be adjusted by pedal operating system. There are two counter weights to balance the angular position of the board and the drafting head. It is more suitable for production drawing office.

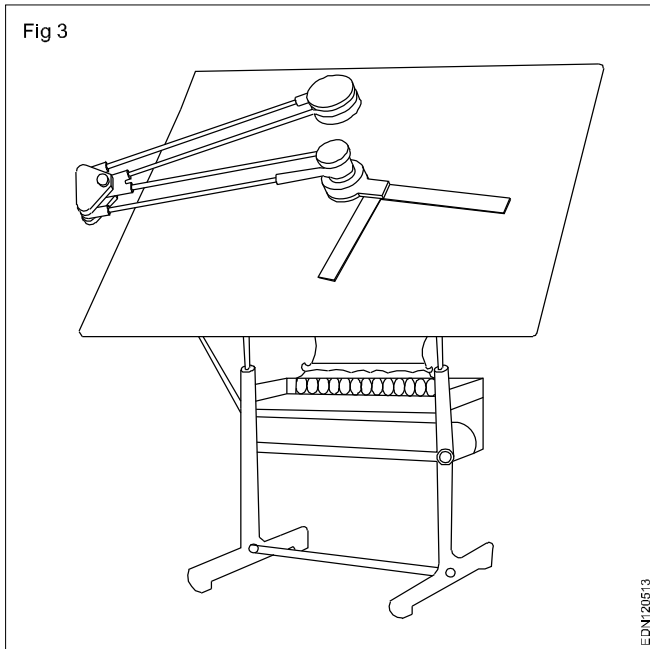

On the other end, a protractor head H with swivelling and locking arrangement is fitted with two scales at right angles.

The protractor head has a spring loaded clutch relieving handle, which rotates and locks at  $15^\circ$  intervals automatically. For setting any angle other than multiples of  $15^\circ$ , the clutch spring is released and by rotating the centre knob, the zero line is set to the required angle and the friction clutch knob is tightened. It is capable of rotating  $180^\circ$ , thereby any angle can be set.

The scales are bevelled on both sides, graduates to 1:1 & 1:2. They can be reversed with the help of dovetail slide fitting.

There is a fine adjusting mechanism on the drafting head to set the scale parallel to the edge of the board. The scales also can be adjusted if there is any error in measuring  $90^\circ$  between them.

Mini drafter is an important device used for making drawing quickly & accurately. This instrument has the combination of T-square, setsquare, protractor and scales, it helps to draw the drawings at a faster rate. (Fig 4,5 & 6)

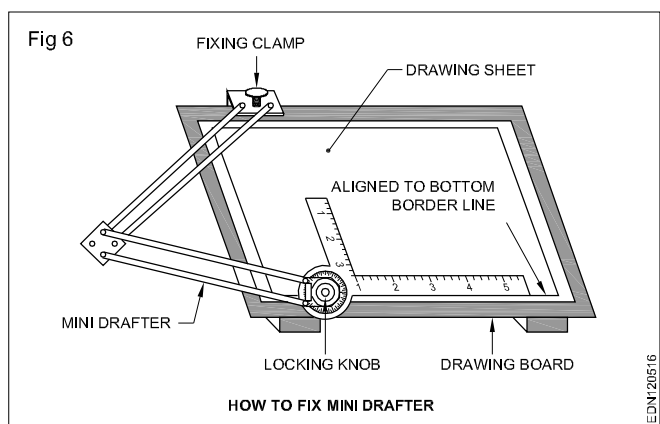
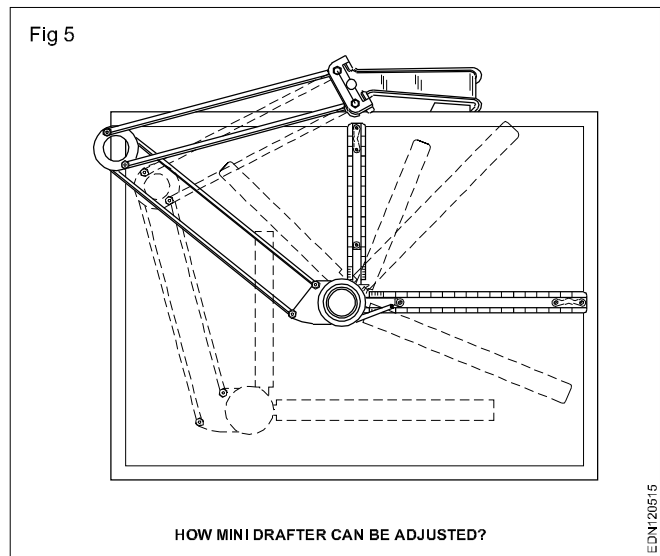
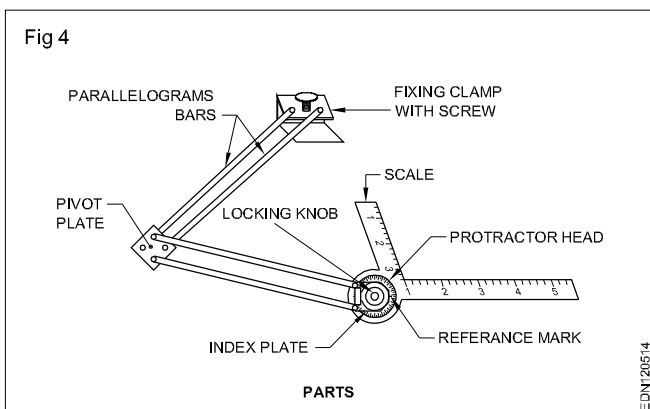

**Erasing shield:** When, on a drawing, if a part of a line or some lines among many other lines need to be erased or modified, in normal way of erasing will damage the other nearby lines. In such a situation an erasing shield is effectively useful. It is a thin metallic sheet having small openings of different sizes and shapes. A suitable opening is aligned to the line to be erased and the line is removed by the eraser. (Fig 7)

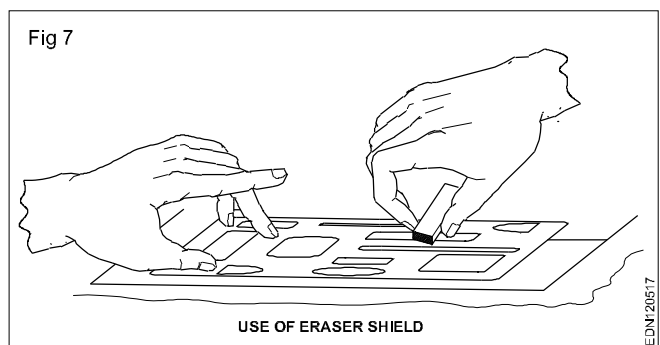



**Drawing instruments - Setsquares, protractor and scale**

**Setsquare** (IS:1361-1988): Transparent celluloid/Plastic setsquares are preferred and are commonly used rather ebonite ones. They are two in number, each having one corner with 90°. The setsquare with 60°-30° of 250 mm long and 45° of 200mm long is convenient for use. Setsquares sometimes loose their accuracy due to internal strains. So they should be tested periodically. (Fig 1)

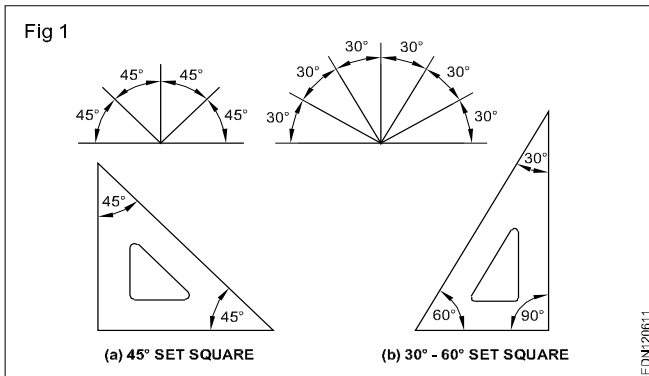

Sometimes set squares have french curves. Set squares are used to draw all straight lines except horizontal lines. It is convenient to draw horizontal lines using Mini drafter.

With the help of Mini drafter and manipulating the 45°, 30°-60° setsquares, angular lines in the multiples of 15°; Parallel lines to a given inclined line and perpendicular to can be drawn.

Set squares with graduated, bevel edge and french curve openings are preferable. They are also used to draw smooth curves. Setsquare should never be used as guide for trimming papers.

**Scales:** Scales are used to transfer and or to measure the dimensions. They are made of wood, steel, ivory, celluloid or plastic, stainless steel scales are more durable. different types of scales used are shown in Figs 1,2 & 3. They are either flat, bevel edged or triangular cross-section. Scales of 15cm long, 2cm wide or 30cm long 3.5cm wide flat scales are in general use. Thin section or bevel edged scales are preferred over thick flat scales. Parallax error will be nil or least while using thin/tapered edge scales. (Fig2)

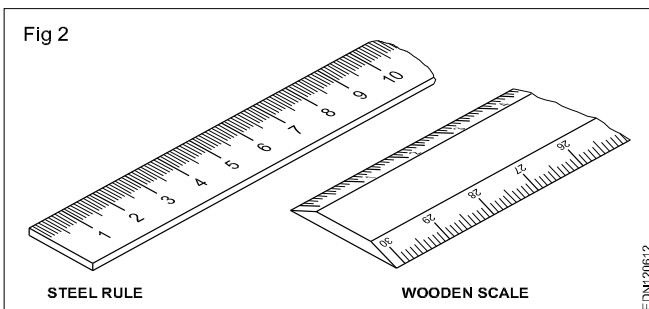

**Protractor:** Protractor is an instrument for measuring angles. It is semi-circular or circular in shapes and is made of flat celluloid sheet.

The angles can be set or measured from both sides, aligning the reference line and point 'O' with the corner point of the angle.

Figure 3 shows how to read or set the angle. Protractor can also be used to divide a circle or drawing sectors.

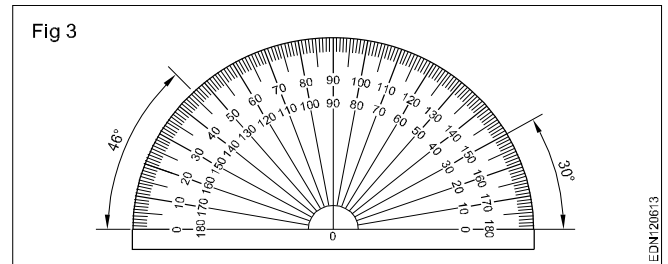

**French curves**

These are made in many different shapes, normally come in sets of 6, 12, 16 etc. French curves are best suited to draw smooth curves/ arcs (which cannot be drawn by a compass) with ease. To draw a smooth curve using french curve first set it by trial against a part of the line to be drawn, then shift it to the next portions.

Each new portion should fit atleast three points on the curve just drawn. It should be seen that the curve (radius) is increasing or decreasing smoothly and no corner should be formed on the curve(Fig 4).

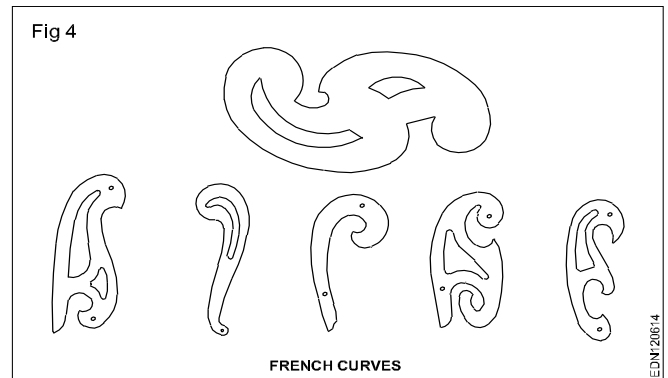
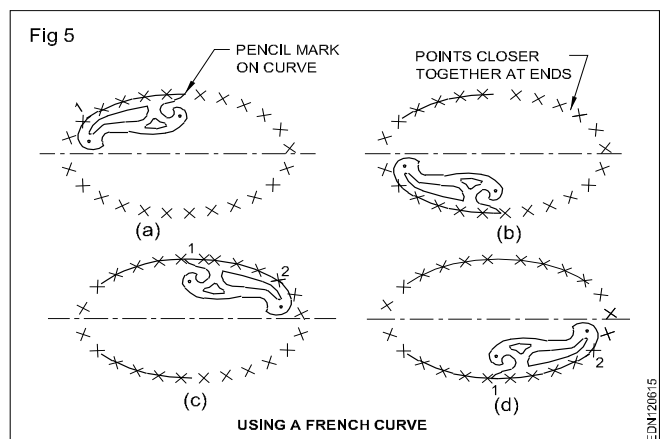

Fig 5 show how to use the french curve and draw a smooth curves. They are made of transparent celluloid (no bevel edge).



**Drawing Instruments box and pencils**

The quality of a good drawing does not only depend on the talent of the craftsmen but also on the quality of instruments he uses.

Drawing instruments are generally sold in sets in boxes, but they are also available separately. The main parts of high grade instruments are generally made of nickel or brass. They must be rust proof. Tool steel is used for making the blades of the inking pen, bow instruments and various screws.

An instrument box contains the following: (Fig 1a to h)

- Large compass (with attachment facility) (a)
- large divider (b)
- Bow compasses, bow divider (c)
- Lengthening bar (d)
- Pen point for attachment (e)
- Screw driver (f)
- Lead case (g)
- Liner (h)

**Large compass** (Fig 2) : It has a knee joint in one leg that permits the insertion of pen or pencil point or attaching lengthening bar with pen or pencil point attached to it. It is used for drawing large circles/arcs also for taking large measurements. The pin on the other leg can be swivelled to vertical position when drawing large circles, while drawing the circles of arcs it should be held in such a way that the needle point leg and pencil point leg should be bent so as to make perpendicular to the paper.

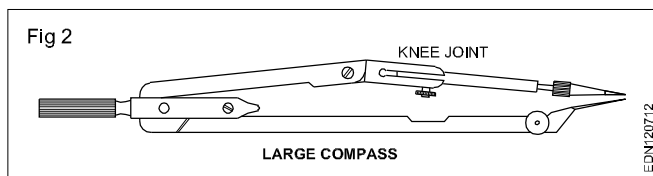

**As a rule while drawing concentric circles, small circles should be drawn first before the centre hole gets worn.**

**Large divider:** It is used to transfer dimensions and dividing lines into a number of equal parts. Divider with adjustable joints is preferable rather than plain legs. (Fig 3)

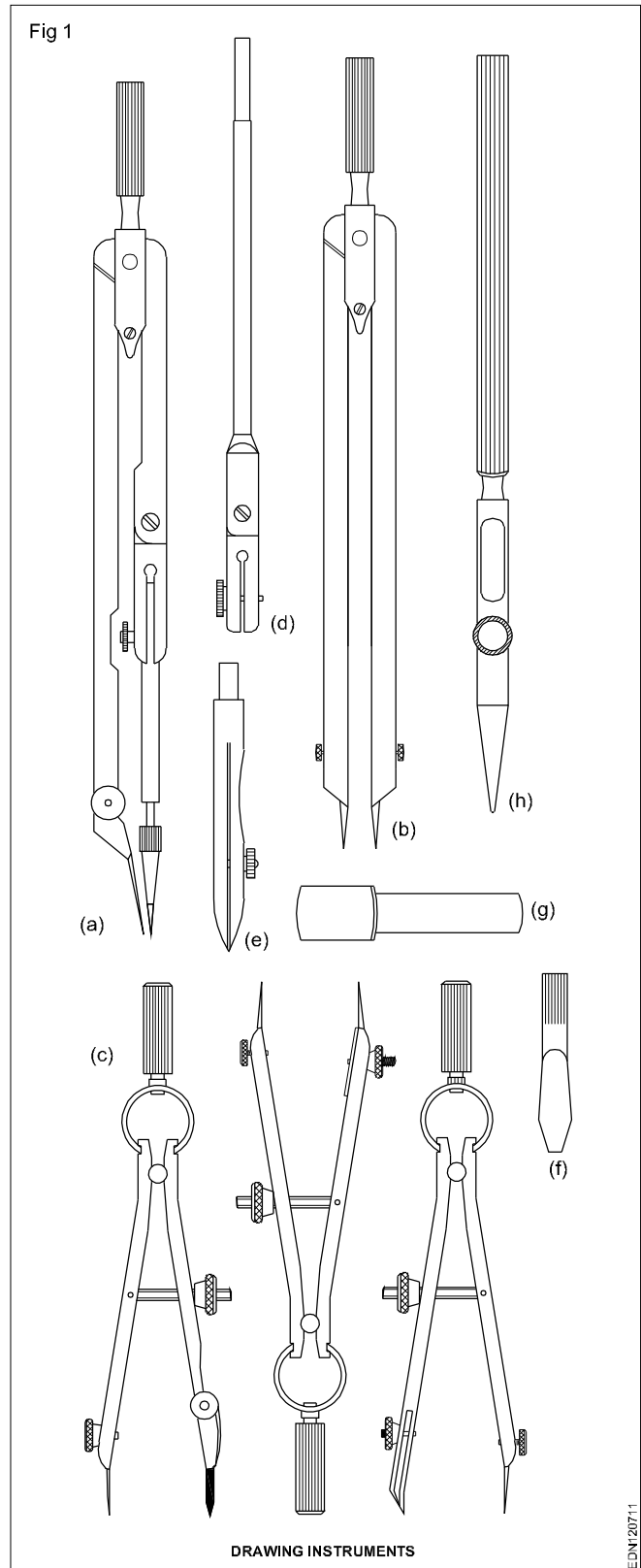
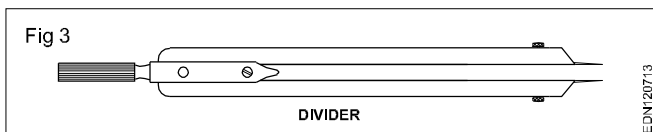

**Bow instruments:** Bow pencil and bow pen compass are used for drawing circles of approximately 25 mm radius. Bow divider is used for marking or dividing smaller spaces. There are two types (i) Integral legs with spring action (4e) (ii) two legs held with a curved spring on top with handle on it.

Bow instruments may have adjusting wheel and nut. To draw circles, it is better to mark the required distance separately and set the instruments and check. Then only the circles or arcs should be drawn on the drawing.

Fig 4 shows different types of bow instruments. Adjustment should be made with the thumb and middle finger. The instrument is manipulated by twisting the knurled head between the thumb and finger.

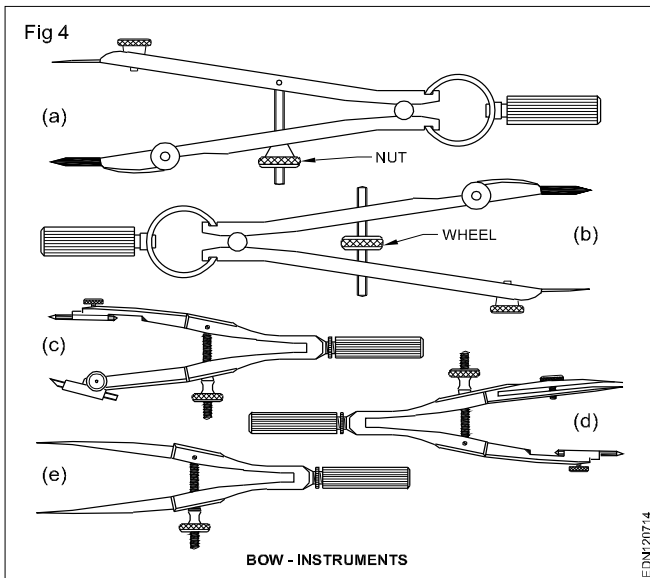

**Drop spring bow pencil and pen (Fig 5):** Drop spring bow pencil and pen are designed for drawing multiple identical small circles. Example: rivet holes, drilled/reamed holes. The central pin is made to move freely up and down through the tube attached to the pen or pencil unit. It is used by holding the knurled head of the tube between thumb and middle finger while the index finger is placed on the top of the pin. The pin point is placed on the centre point of the circle to be drawn (Fig 5) and pencil or pen is lowered until it touches paper. The instrument is turned clockwise and the circle is drawn.

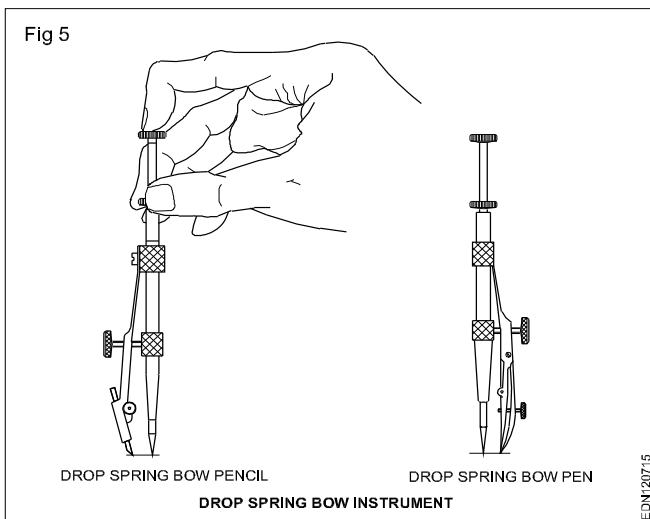

**Inking pen or liner or ruling pen (Fig 6):** It is used to ink the straight lines drawn with the instruments but never for free hand lines or lettering.

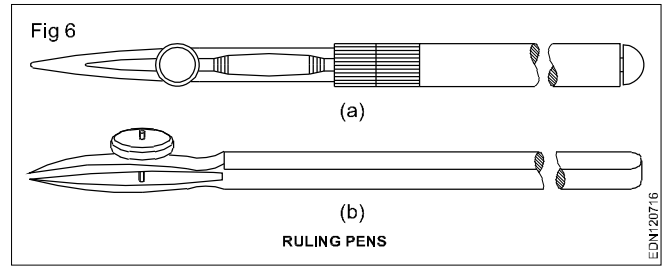

**Lengthening bar (Fig 7):** To draw larger circles, it is fitted to the compass. The pencil point or pen point is inserted to its end.



Replaceable spare pencil, pen and needle points for compass are available in the instrument box.

**Screw driver (Fig 8):** Used for adjusting the screws of the instruments.

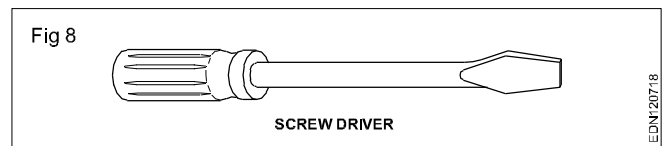

**Lead case (Fig 9):** Lead case is the box for holding the pencil leads.

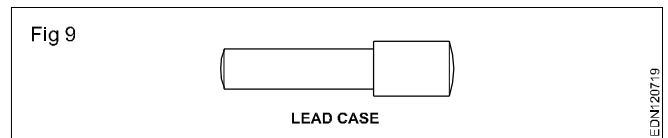

**Pin, Clip, Cello tape:** Drawing sheet should be fastened on to the drawing board firmly on temporary basis so that it does not shake during preparing drawing. For this purpose the pins, clips and cello tapes are used (Fig 10)

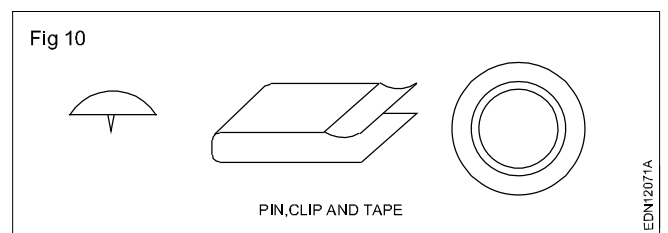

### Pencils, Grade and Selection

**Pencils (Fig 11):** In drawing office, standard pencils (lead encased in wood) and semi-automatic pencils are made use. Pencil leads are made of graphite with kaolin (clay) of varying proportion to get the desired grades. More the kaolin higher the hardness.

**Grades of pencils:** Pencils are graded according to the hardness or softness of the lead.

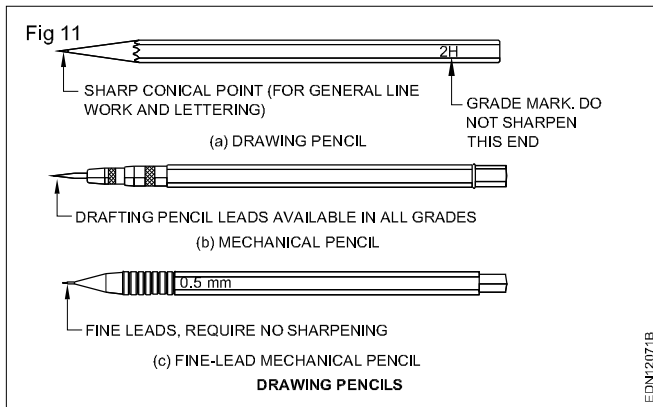

**Hardest pencil is 9H grade and softest pencil is 7B grade.** Selection of grade of pencils depends on the type of line work required and paper on which it is used.

Softer lead pencils are used to produce thicker and darker line work, but they wear out quickly. Medium grade of H, 2H are used for general line work as well as for lettering.

Harder grade leads produce lighter and thinner lines. Most construction line work is done with 4H, 5H and 6H pencil leads, producing thin but also sufficiently dark by exerting pressure. Depending upon the individuals touch and the style of writing, right pencil may be selected.

For any drawing on drawing paper or tracing paper, lines should be black, particularly drawings which are to be reproduced. For this purpose, the pencil chosen must be soft enough to produce jet black lines as well hard enough not to smudge easily. The point should not crumble under normal working pressure. The pencils should not be hard and cut grooves on the paper while drawing with normal pressure, Pencils H, 2H or 3H depending upon the paper (quality) and weather conditions are selected.

In summer the pencil leads become softer due to rise in temperature, so slightly harder pencils can be made use of softer grade pencils are used on smooth surfaces for lettering and arrow head. During rainy season or when humidity is more, the drawing paper expands and wrinkles form, pencil leads become harder. So softer pencils are to be used. Whatever may be grade of pencil you use, always prefer quality pencils/leads viz., Venus, Kohinoor, Apsara etc.

For better line work, i.e., dense black lines, prefer paper which is not having too much teeth (roughness).

**Selection of pencils:** Pencil grades vary from one brand to another brand. Select the grades of the pencil depending upon the type of line work. For construction lines, you can choose 2H or 3H, for lettering and object lines grade H pencils. In general H, HB and 2H are used.

H medium hard  
HB medium soft  
2H hard

Pencils used for drawing are always hexagonal in cross sections as they do not roll easily even when they are placed on slope surfaces. Its cross section helps in rotating the pencil, while drawing lines, to give uniform line thickness.

Now-a-days automatic (Mechanical) pencils or clutch pencils are available in different sizes (lead dia 0.3, 0.5, 0.7 or 0.9 mm). They are easy to handle as there is no reduction of holding length pencil leads can be replaced, as per required grade of hardness. They produce lines of uniform width without sharpening. (Fig 11)

**Free hand drawing of lines**

**Sketch by free hand**

Follow the procedure and sketch the following practice No.1 to 17 in A3/A4 sheets.

**Practice**

**1 To draw horizontal thick and thin lines. (Fig 1)**

- Sketch two vertical thin guide lines AB & CD.
- Mark points on the vertical lines AB & CD, 5 mm intervals approximately.
- Draw the lines by free hand between the two points sketch thick and thin alternatively.

**Lengthy lines can be drawn with the forearm motion and short lines are drawn with the wrist motion.**

**Keep uniform pressure while sketching.**

**Horizontal lines are drawn from left to right. (Fig 1B)**

**While sketching straight lines between two points keep your eyes on the point to which the line is to go rather than the point of pencil.**

**Avoid of drawing whole length of line in one single stroke.**

**Prevent using eraser often.**

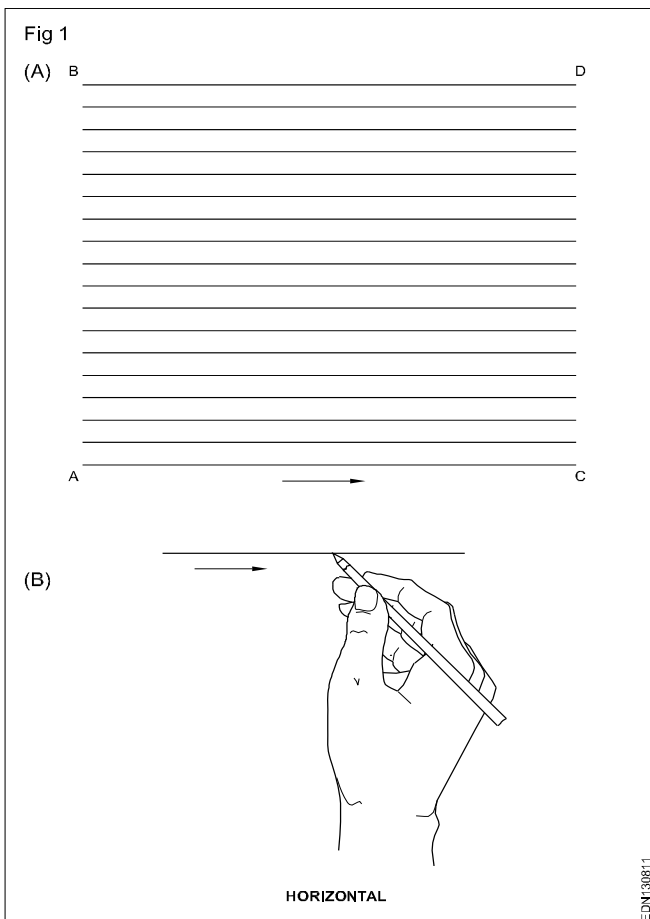

**2 To draw vertical lines in thick and thin. (Fig 2)**

- Sketch two horizontal thin guide lines AB & CD.
- Mark points on the horizontal lines AB & CD, 5 mm intervals.
- Sketch the line in free hand between the two points with thick and thin alternatively.

**Vertical lines are drawn from top to bottom. (Fig 2B)**

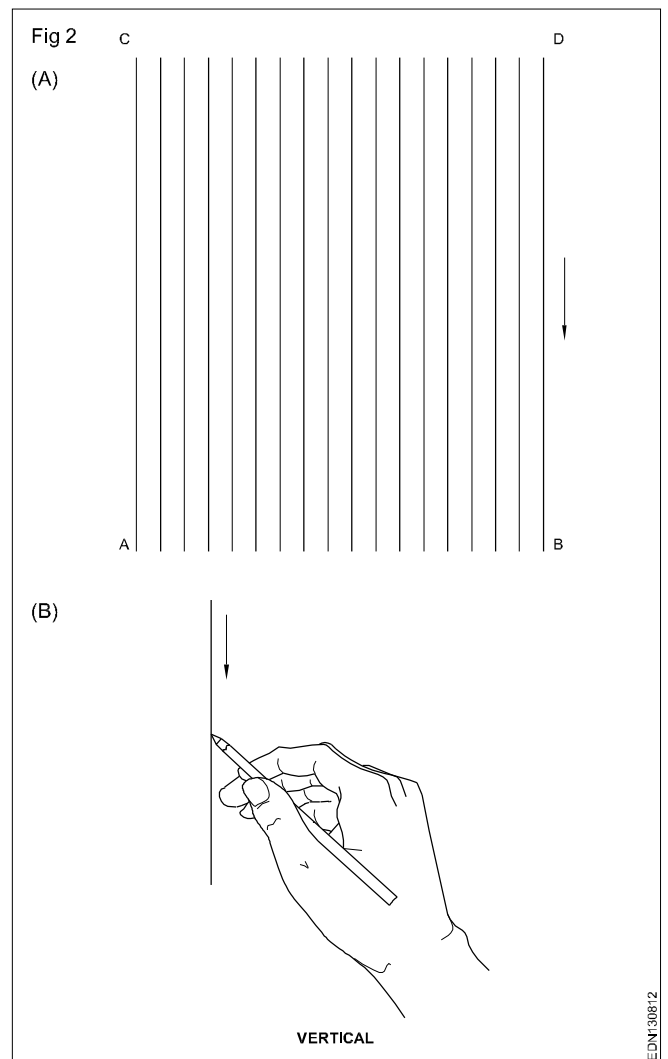

**3 Sketch the inclined lines as shown in figure with thick and thin lines. (Fig 3)**

- Sketch two axis AB & CD.
- On the horizontal and vertical axis AB and CD, mark points with 5 mm intervals.
- Draw thick and thin lines in the direction as shown in the figure alternatively.

Inclined lines running upward are drawn left to right i.e bottom to top. (Fig 3B)

The pencil point need not to be too sharp.

Hold the pencil freely and not close to the point.

It is better that the pencil can be hold 30 mm away from the tip of the pencil lead.

Fig 3

(A)

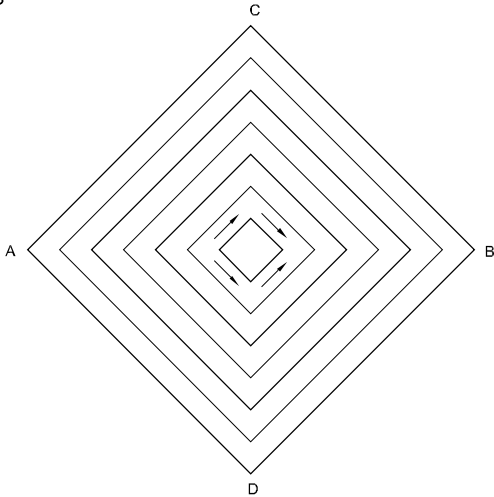

(B)

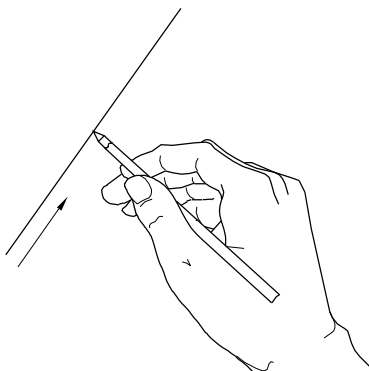

INCLINED

EDN130813

**4 Sketch the given plane figure as shown. (Fig 4)**

- Draw the horizontal straight line in free hand and mark off 60 mm approximately.
- Draw a vertical straight line of 60 mm long from the base.
- Draw horizontal & vertical parallel lines and form a square box of 60 mm sides.
- Darken the lines of the surfaces in figure using thick line.
- Erase the unwanted lines and complete the plane figure.

**Do not place any dimensions in the figure.**

Fig 4

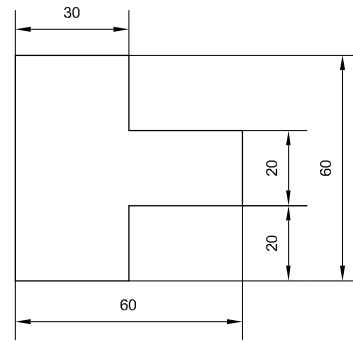

EDN130814

**5 Sketch the plane figure as shown. (Fig 5)**

- Sketch a square box of 30 mm side in thin lines.
- Mark off the dimensions as shown in figure approximately.
- Thicken the required lines.
- Erase the unwanted lines and complete the figure.

Fig 5

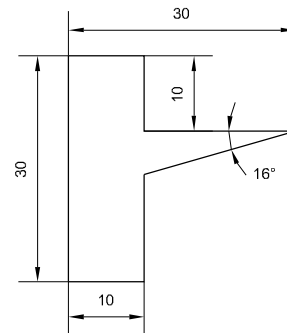

EDN130815

**6 Sketch the plane figure as given. (Fig 6)**

- Form a square box of 30 mm side in thin lines.
- Set of the dimensions and angle as shown in figure.
- Draw the lines and remove the unwanted lines.
- Complete the figure.

Fig 6

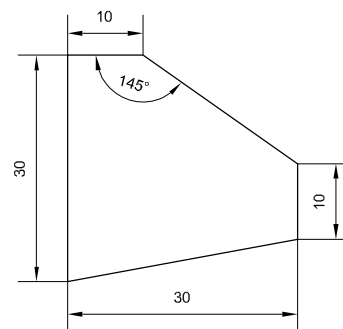

EDN130816

**7 Sketch a circle of diameter 50 mm. (Fig 7)**

- Sketch a square box of given diameter, mark the mid points and join the mid points of horizontal and vertical sides. (Fig 7A)
- Join the corners (diagonals) of the square box and mark the radius of the given diameter. (Fig 7B)

- Join all the 8 points by a smooth curve and complete the circle. (Fig 7C)
- Erase the unwanted lines and darken the curve. (Fig 7D)

**Side of the square = Diameter of the circle**  
**Radius of circle = Half of the square side.**

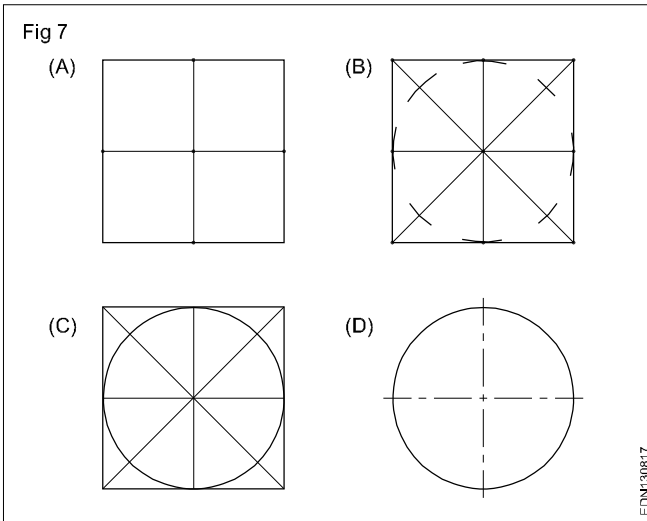

**8 Sketch the template as shown in figure. (Fig 8)**

- Sketch a square box of 60 mm side.
- Sketch the semi-circle on right side of the square as shown in figure.
- Darken the lines as in figure and complete the shape of the template.

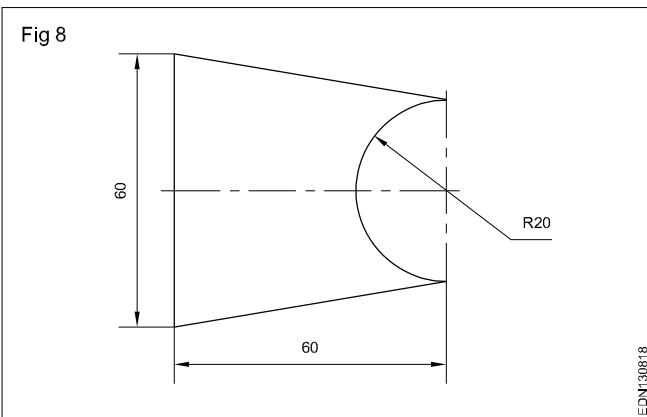

**9 Sketch the given figure. (Fig 9)**

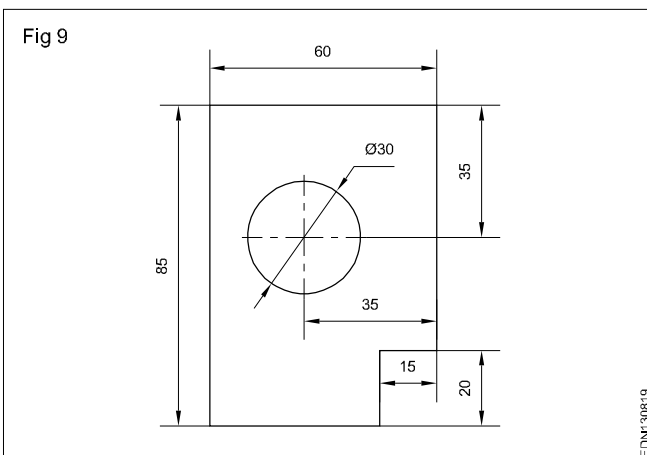

- Sketch a rectangular box of 85 mm x 60 mm.
- Mark of the dimensions as shown in figure.
- Follow the method given in Ex.7,8 and sketch the circle.
- Thicken the required lines.
- Erase the unwanted lines and complete the figure.

**10 Sketch the blank shown in figure. (Fig 10)**

- Sketch a rectangular box of 75 mm x 60 mm as is figure.
- Mark the other dimensions as shown in figure.
- Thicken the required lines of the template.
- Erase the unwanted lines and complete the figure.

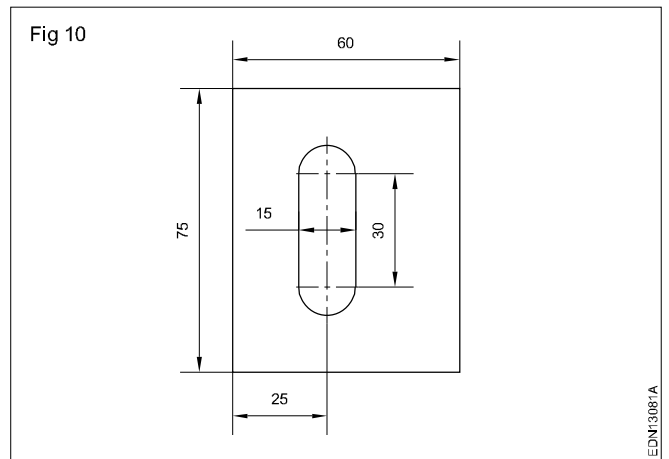

**11 Sketch the curved shape blank plane figure as given in figure. (Fig 11)**

- Draw a vertical straight line and horizontal straight line intersecting each other at right angles.
- Mark off 20 mm on either side of the vertical line from the intersecting point of the straight lines.
- Sketch semi-circle of R 20 mm top and bottom as in figure.
- Join the two semi-circles with vertical lines.
- Sketch the three circles of  $\phi$  10 mm.
- Darken the lines and complete the figure.

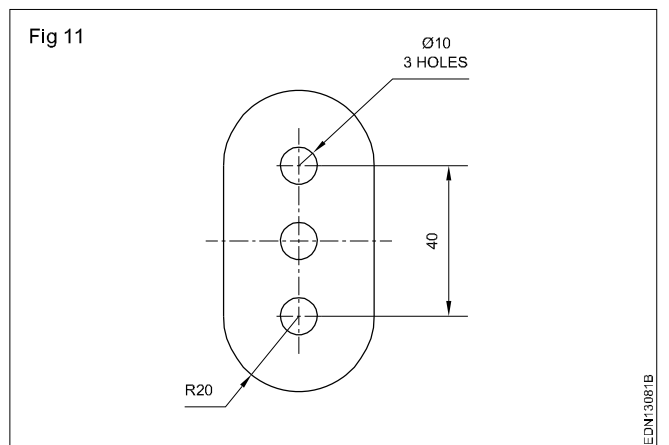



**12 Sketch the template as shown. (Fig 12)**

- Draw a vertical straight line.
- Draw two horizontal straight lines intersecting the vertical line keeping 40 mm away.
- Sketch the two curves as in figure and join the curves.
- Erase the unwanted lines and complete the figure.

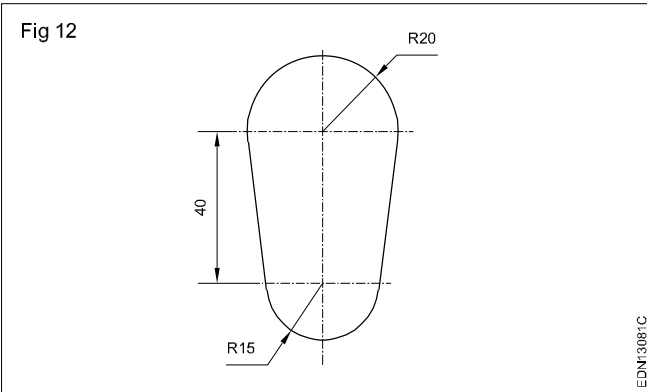

**13 To sketch an ellipse of given major and minor axis. (Fig 13)**

- Draw a horizontal and a vertical line intersecting each other at right angles.
- On the horizontal line mark the half of the major axis on either side of the centre and similarly half of the minor axis on the vertical line.
- Through these points draw horizontal and vertical parallel lines and form a rectangular box.
- Sketch the small arcs with thin lines.
- Join the other portion by smooth curve and complete the ellipse.

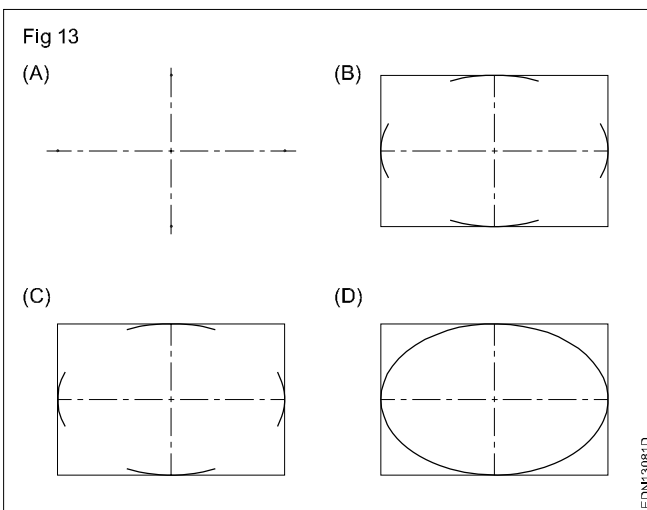

**14 Draw the pattern of 50 mm side by free hand. (Fig14)**

- Draw a square by free hand.
- Divide one horizontal and one vertical side into each ten equal parts.
- Draw a thin horizontal and vertical line through the parts marked.

- Darken the squares as per exercise drawing.
- Rub off the thin construction lines and complete the exercise.

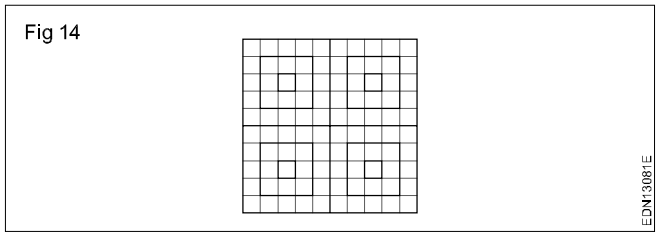

**15 Draw the pattern of sides 70 mm and 35 mm by free hand proportional to the size. (Fig 15)**

- Draw a rectangle proportionately.
- Join the diagonals.
- Draw parallel lines to the diagonals approximately at 10 mm distance from each other as shown in the exercise.

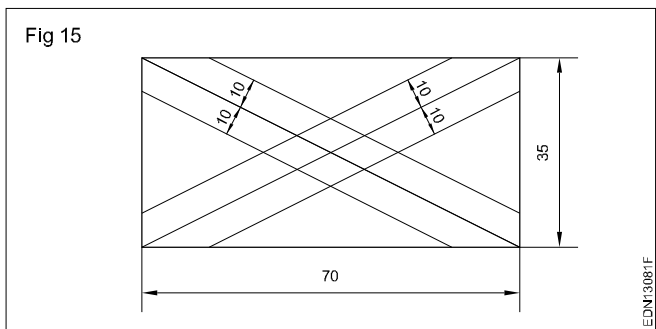

**16 Draw a square ABCD of side 80 mm approximately by free hand. (Fig 16)**

- Join diagonals (thin line).
- Draw the perpendicular bisectors from two adjacent sides (free hand).
- On side AB, mark EF = 20 mm.
- Join E and F to centre of square.
- Draw a line at a distance 10 mm parallel to EF.
- The parallel line cuts the inclined lines EO and FO at G and H.
- Join GH, GE and HF.
- Follow the procedure and draw trapeziums similar to EFHG on the remaining three sides.
- Join the lines shown in the Fig 16 and rub off the thin line and finish the drawing.

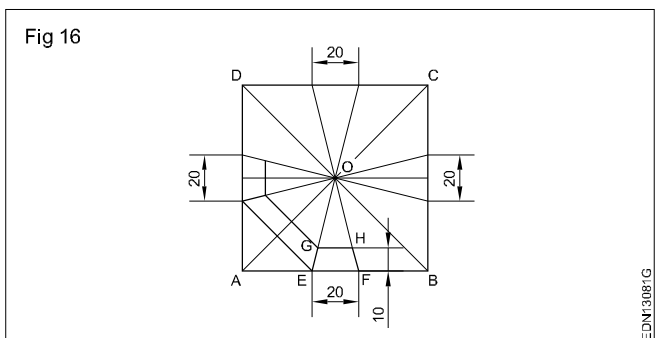



**17 Sketch the given pattern by free hand. (Fig 17)**

- Mark the mid point of the line AB.
- Draw free hand circles of  $\phi$  35 and  $\phi$  50 on the mid point of the vertical line.
- Draw two circles  $\phi$  20 mm using A and B are the centres.
- Draw two circles of  $\phi$  10 from points A and B.
- Complete the drawing after removing unwanted lines.

**Plane figures for which the procedure are not given follow the constructional methods given in Skill sequences and the Procedures for plane figures and complete them.**

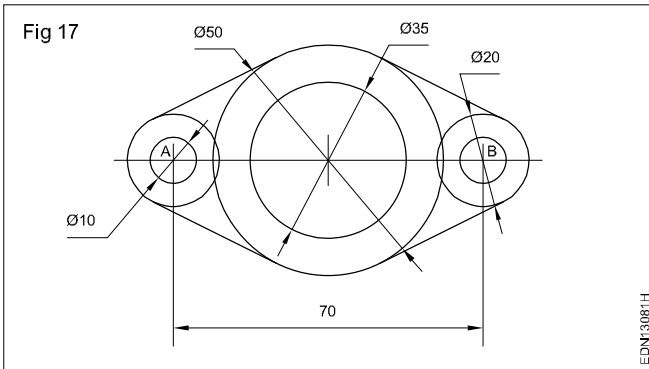

**Types of lines**

A point represents a location in space, having no width or height. It is represented by drawing intersection of lines or a dot. (Fig 18)

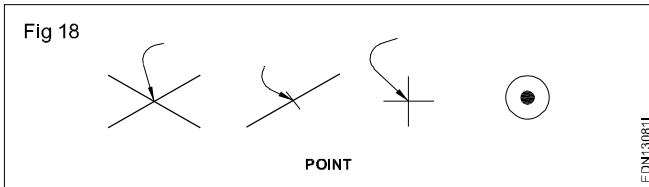

Line is the path of a point when it moves. It has no thickness and are of two types:

- Straight line
- Curved line

**Straight line:** It is the path of a point when it is moving in a particular direction. It has only length and no width. (Fig19) Also a straight line is the shortest distance between two points. Straight line, depending on its orientation are classified as Horizontal, Vertical and Inclined or Oblique line.

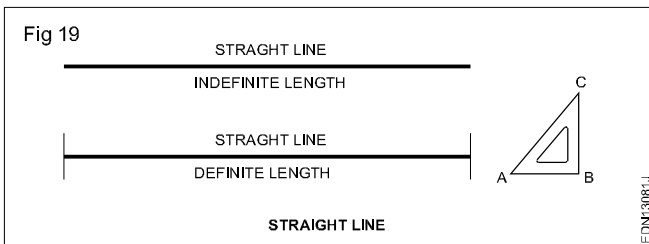

**Horizontal line (Fig 19):** Horizontal lines are those which are parallel to a horizontal plane. Example of horizontal plane is the surface of a still water. (Fig 20)

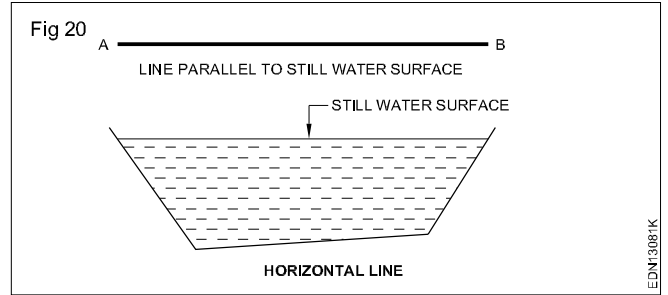

**Vertical line (Fig 21a):** Lines which are perpendicular to horizontal lines are called vertical lines. It can be treated as a line along the plumb line of the plumb bob or parallel to a plumb line. (Fig 21b)

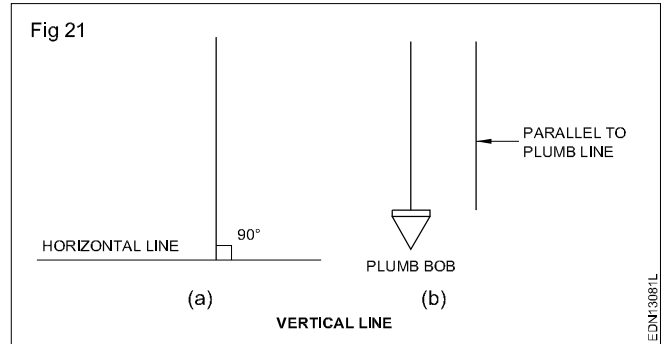

**Inclined line or Oblique line:** A straight line which is neither horizontal nor vertical is called an inclined line. (Fig22)

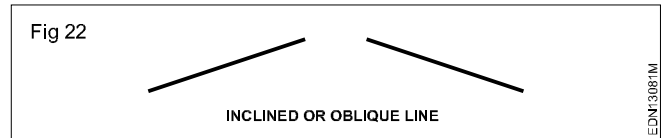

**Curved line:** It is the path of a point which always change its direction. Examples of curved lines are shown in (Fig23).

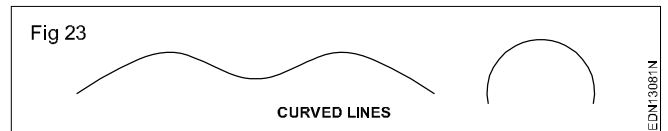

**Parallel lines:** They are the lines with same distance between them. They may be straight lines or curved line. Parallel lines do not meet when extended. (Fig 24)

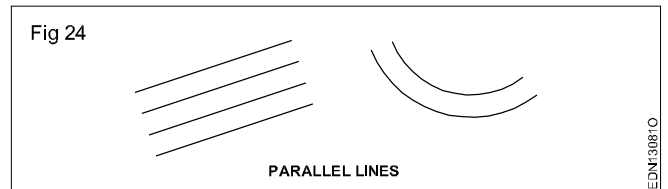

**Perpendicular lines:** When two lines meet at 90°, the two lines are said to be perpendicular to each other. One of the lines is called as reference line. (Fig 25)

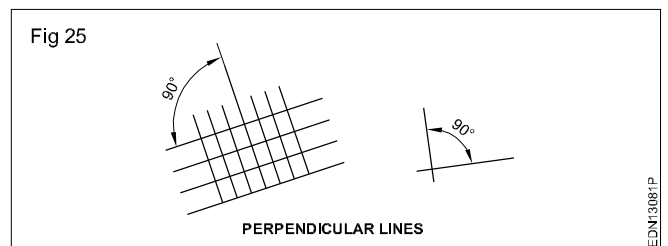

**Free hand drawing - Polygons and ellipse**

**Names of polygons:** Polygons are named in terms of their number of sides as given below: (Fig 1)

S.No	Name	No. of sides
1	Pentagon – a	Five sides
2	Hexagon – b	Six sides
3	Heptagon – c	Seven sides
4	Octagon – d	Eight sides
5	Nonagon – e	Nine sides
6	Decagon – f	Ten sides
7	Undecagon – g	Eleven sides
8	Duodecagon – h	Twelve sides

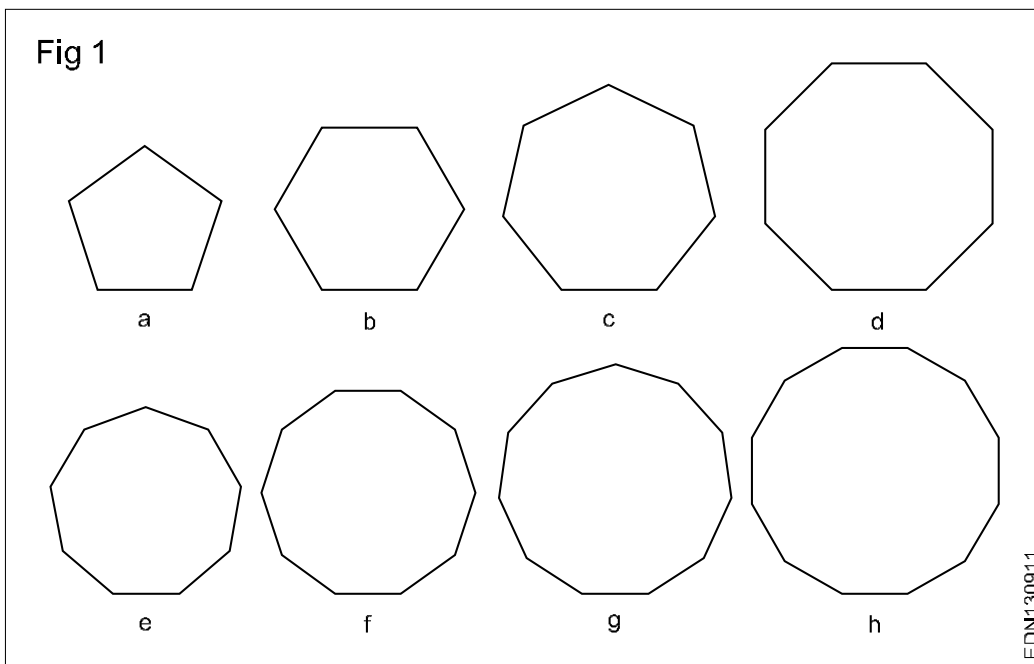

- Pentagon inscribed polygon. (Fig 2)

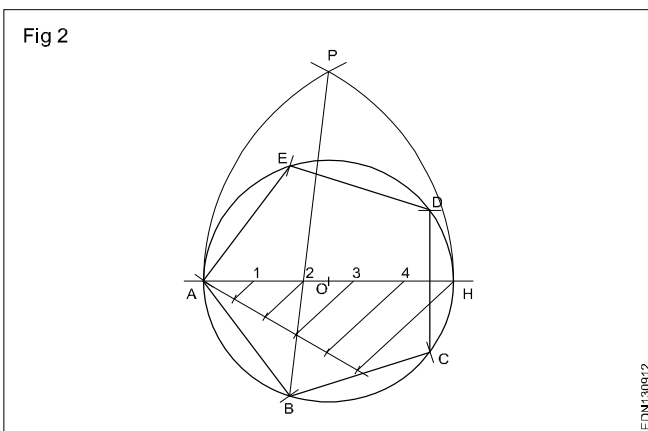

- Pentagon circumscribed polygon. (Fig 3)

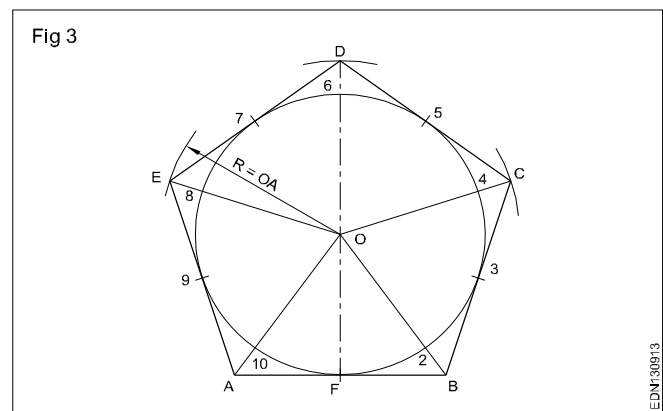

- O as centre and OF as radius describe a circle of dia 50 mm.
- Draw the line DF vertically beyond the top of the circle.

- Divide the circle into 10 equal parts. (Twice as many equal parts as the number of sides)
- Points 1,3,5,7 and 9 are the tangent points of the pentagon.
- Join O2, O4, O6, O8, O10 and extend to a convenient length.
- Draw a tangent to the circle through point 1 (F).

### Hexagon

- The sum of the interior angle and the corresponding external angle is  $180^\circ$ . (Fig 4)

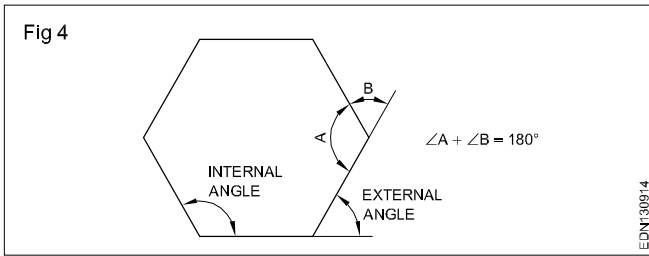

- Hexagon arc method (Fig 5)

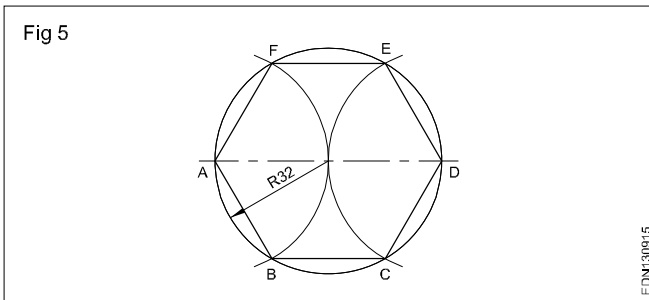

- Hexagon arc method (Fig 6)

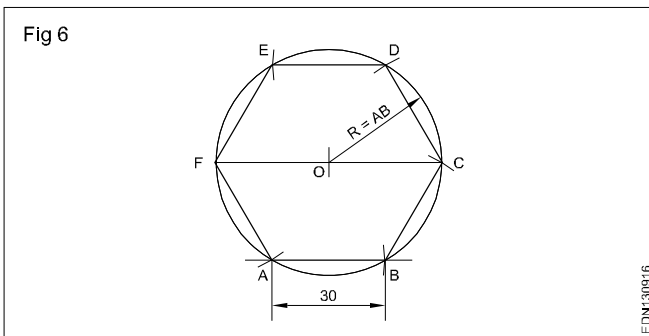

- Hexagon across flats method (Fig 7)

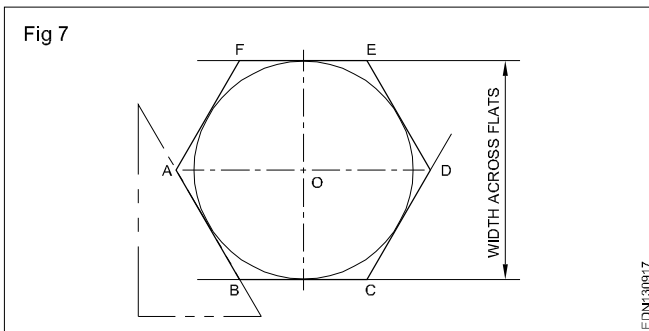

- Hexagon regular heptagon (Fig 8)

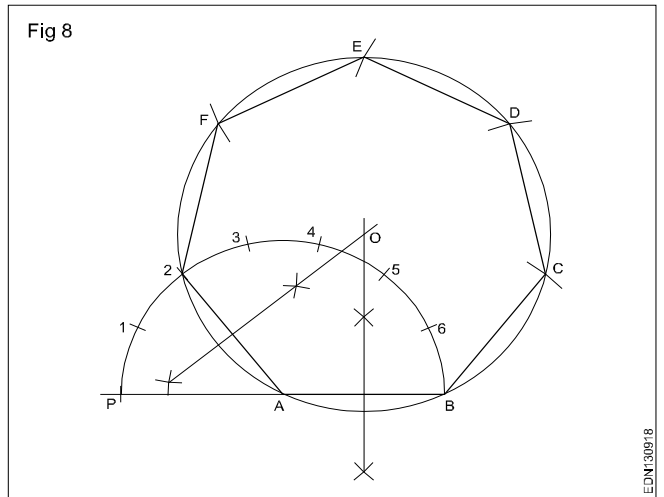

- Semi-circular method heptagon (Fig 9)

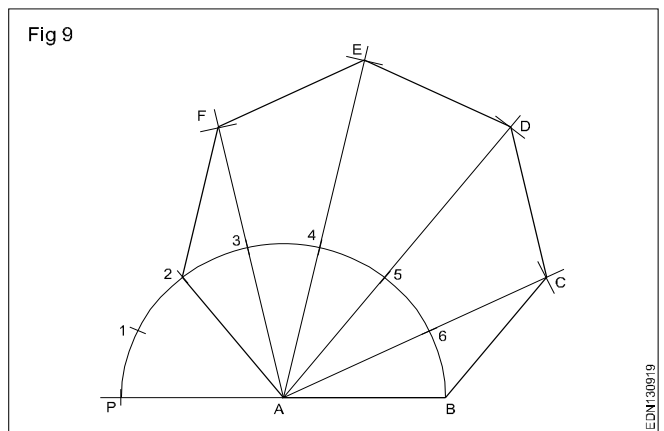

- Hexagon perpendicular bisector method. (Fig 10)

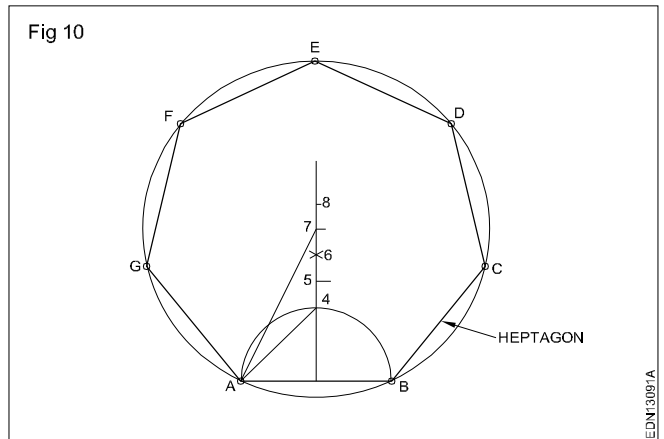

- Special method octagon (Fig 11)

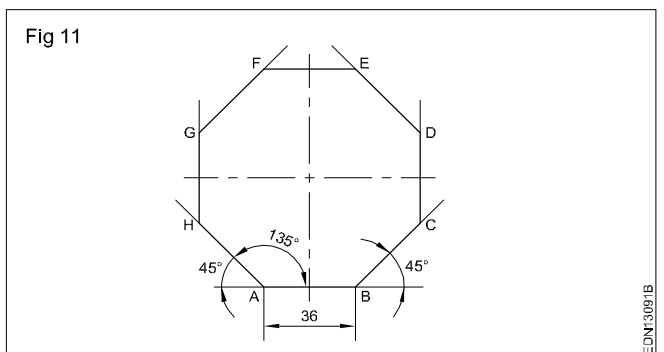

# Freehand drawing of ellipse

## Elements of an ellipse (Fig 1)

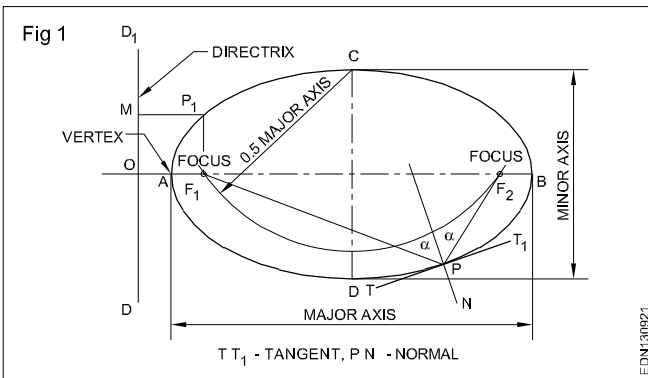

**Major axis:** It is the longest distance which passes through the centre, at right angle to the fixed lines called the directrix. AB is the major axis.

**Minor axis:** It is the maximum distance which bisects the major axis at right angle. It will be parallel to the directrix. CD is the minor axis.

**Directrix:** It is a straight line perpendicular to the major axis.

**Focus:** When an arc is drawn with C or D as centre and radius equal to half the major axis i.e.  $\frac{AB}{2}$ , it is cut at two

points  $F_1$  and  $F_2$  on the major axis.  $F_1$  and  $F_2$  are the focal points of an ellipse  $F_1$  or  $F_2$  is the focus. The sum of the distances from  $F_1, F_2$  to any point on the curve i.e.,  $F_1P + F_2P$  is always constant and equal to the major axis.

**Focal radii:** The distances from point P on the curve to the focal points  $F_1$  and  $F_2$  are called focal radii. Sum of the focal radii is equal to the major axis.

**Eccentricity:** The ratio between the distances from the vertex to focus and vertex to the directrix is called the eccentricity and is always less than one.

$AF_1/AO$  is less than one.

It can also be stated as the ratio of the distance from focus onto any point on the curve, say  $P_1$  and the perpendicular distance of  $P_1$  from the directrix. i.e.  $P_1F_1/P_1M$  is a constant.

**Vertex:** The end points of the major axis on the curve are called vertex. (A, B)

**Tangent and normal to an ellipse:** Normal is the line bisecting the angle  $F_1PF_2$  in Fig 1. Tangent is a line at  $90^\circ$  to the normal and touching the ellipse.

Directrix, axis, focus, vertex and tangent are the elements common to ellipse, parabola and hyperbola.

All ellipse can be constructed in different methods:

- Rectangle method (oblong)
- Concentric circle method
- Arcs method

- String and pins method
- Paper trammel method
- 4 centre method
- Conjugate diameters method
- Eccentricity method

**Practical applications:** In general, a circle in a pictorial drawing is represented by an ellipse. The use of elliptical shape is rarely used for engineering applications. Ellipse is dealt extensively in mathematical books. Elliptical shape is adopted for better aesthetics.

- 1 Construct an ellipse by concentric circle method. Major axis 80 mm. Minor axis 40 mm. (Fig 2)

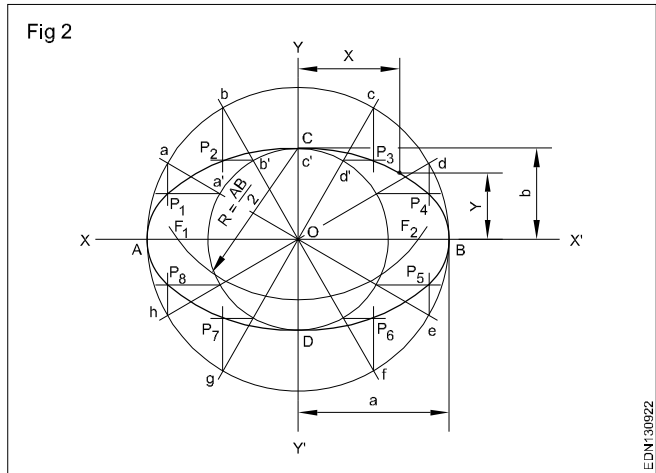

- Draw the major axis AB (80 mm) and minor axis CD (40 mm), bisecting at right angle at O.
- 'O' as centre OA and OC as radius, draw two concentric circles.
- Draw a number of radial lines through 'O' (say 12) cutting the two circles.
- Mark the points on the outer circle as a,b,c.
- Similarly mark the corresponding intersecting points on inner circle as a',b',c'.
- From points such as a,b,c... draw lines parallel to minor axis.
- From points such as a', b',c'.... draw lines parallel to the major axis to intersect with the corresponding vertical lines at points  $P_1, P_2, P_3$ .... etc.
- Join all these points with a smooth curve by free hand or using "french curve" and form the ellipse.
- To find the 'Foci' - with half the major axis (a) as radius and with 'C' on the minor axis as centre, draw an arc cutting the major axis, at two points, mark them as  $F_1F_2$  the focus points of the ellipse.

- 2 Construct an ellipse by four centre method - Major axis = 80 mm and Minor axis = 40 mm - Type A. (Fig 3)

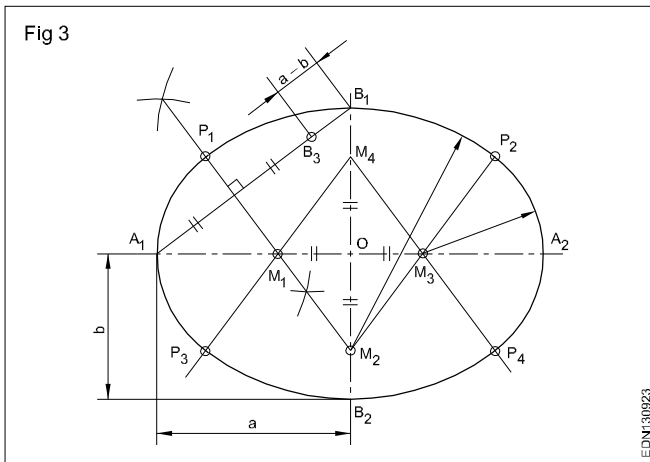

- Draw the major axis  $A_1A_2$  and minor axis  $B_1B_2$ .
- Set off  $B_1M_2$  and  $B_2M_4$  equals to  $A_1B_1$ .
- Join  $A_1B_1$  and set off  $B_1B_3$  equal to  $a-b$  ( $a = OA_1$ ,  $b = OB_1$ )
- Draw a bisector on  $A_1B_3$  which intersects  $A_1A_2$  at  $M_1$ .
- Similarly obtain  $M_3$ .  $M_2$  &  $M_4$  as centres and  $B_1M_2$  as radius, draw arcs  $P_1P_2$  &  $P_3P_4$ .
- $M_1M_3$  as centres and  $M_1P_1$  as radius, draw arcs  $P_1P_3$  &  $P_2P_4$  and complete the ellipse.

3 Construct an ellipse by four centre method - Major axis = 80 mm and Minor axis = 40 mm - Type B. (Fig 4)

- Draw the rectangle EFGH (80 x 40) and draw AB & CD represent major and minor axis.
- Join EC
- Bisect AE and mark P the mid-point.

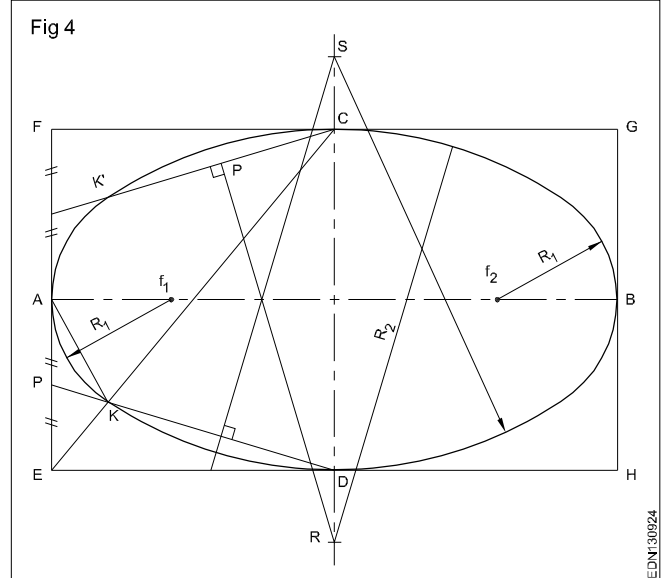

- Join DP meeting EC at K.
- Draw perpendicular bisector of KD and extend DC and locate point 'S'.
- 'S' as centre SD as radius draw the arc KD.
- Similarly get the point 'R'.
- Join AK and draw perpendicular bisector on it, and meet AB at  $f_1$ .
- ' $f_1$ ' as centre,  $Af_1$  as radius, draw an arc  $KK'$ .
- Mark centre ' $f_2$ ' so that  $Bf_2 = Af_1$ .
- Now R, S,  $F_1$  &  $F_2$  are the four centres of the ellipse.

Similar to the procedure followed for drawing curves KD and  $KK_1$  and complete the ellipse

**Free hand drawing of geometrical figures and block with dimension**

**Free hand sketching:** Apart from making drawing using instruments, often craftsman will be required to make drawings by free hand.

Free hand sketching is an easiest method to express the shape of a piece part or a component by an engineer or craftsman.

Here are a few examples of situation wherein free hand sketches will have to be necessarily made.

- On the site sketching for production/maintenance.
- Recording of initial idea of a design.
- For quick exchange of ideas among designer, draughtsman, technician.
- Urgency (free hand sketching takes less time)

To make free hand drawings/sketches, the craftsman has to acquire new skills and one has to have considerable practice to be able to make good free hand sketches. Ability to make good free hand sketches is an asset to any craftsman.

Free hand sketches are not usually made to scale. However, they should be as nearly to the proportions as possible.

**Materials for free hand sketching:** A4 size sheet (preferably a pad instead of loose papers) pencils of soft grade. Example H, HB, and a good quality eraser are the only materials required. For drawing different darkness, the pencil points should be sharpened to conical shape.

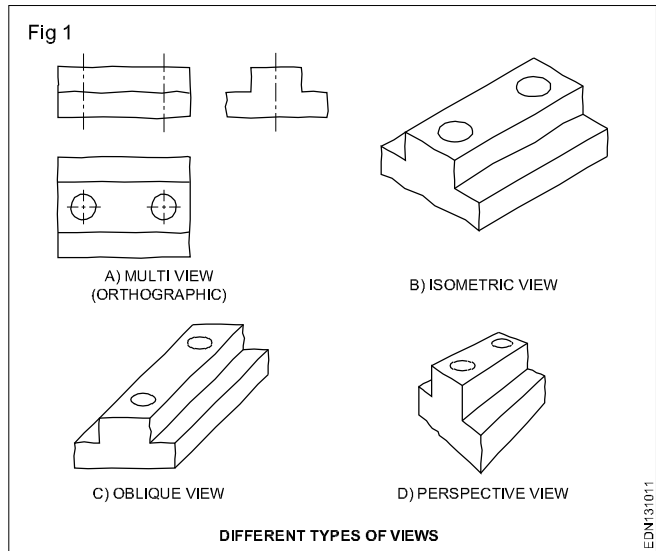

**Cube (Fig 2)**

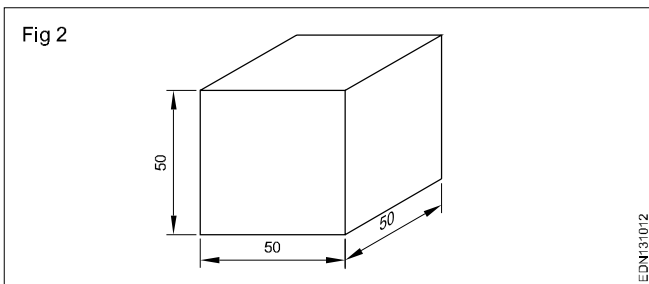

**Square block (Fig 3)**

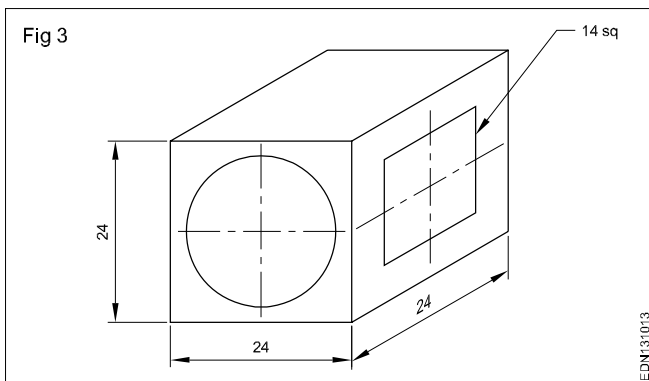

**Rectangular block (Fig 4)**

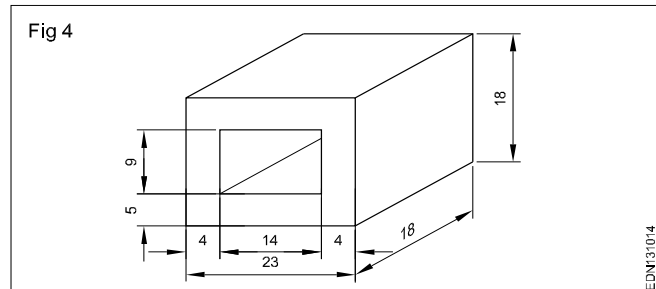

**Square block (Fig 5)**

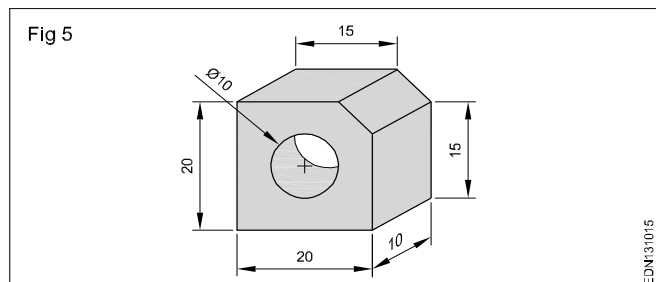

**Cylinder (Fig 6)**

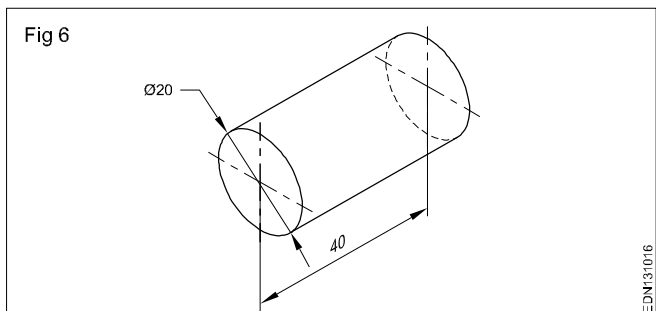

Free hand drawing of transferring measurement from the given object

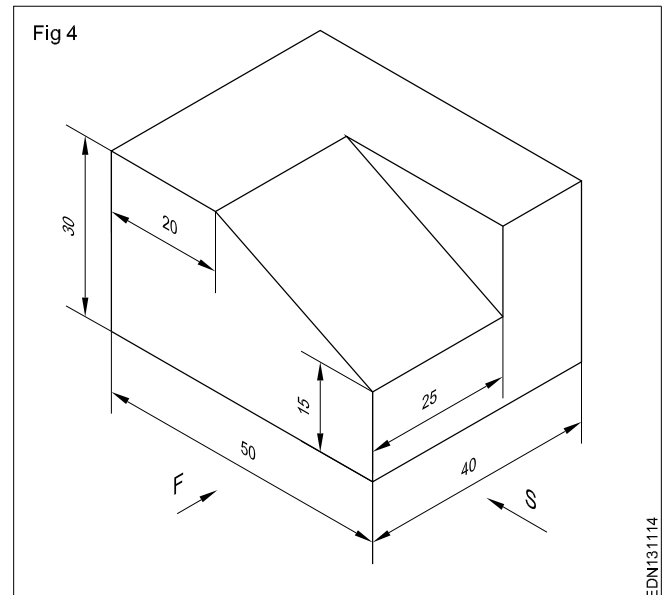
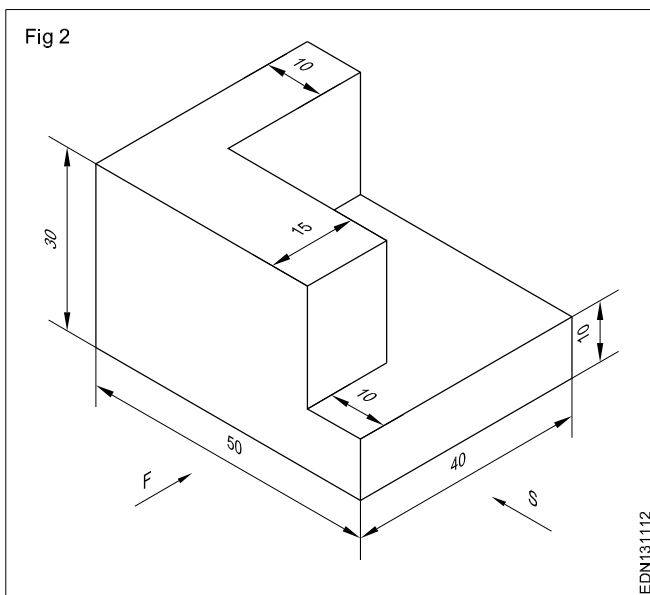
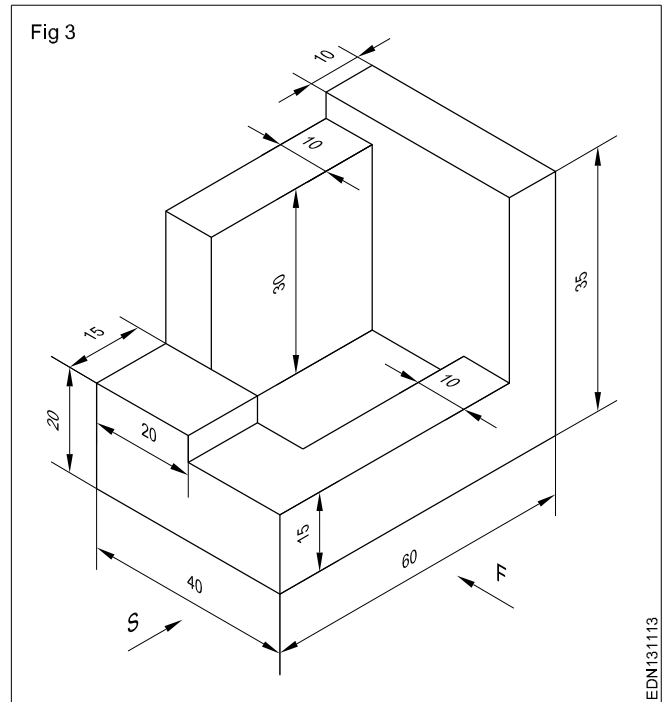
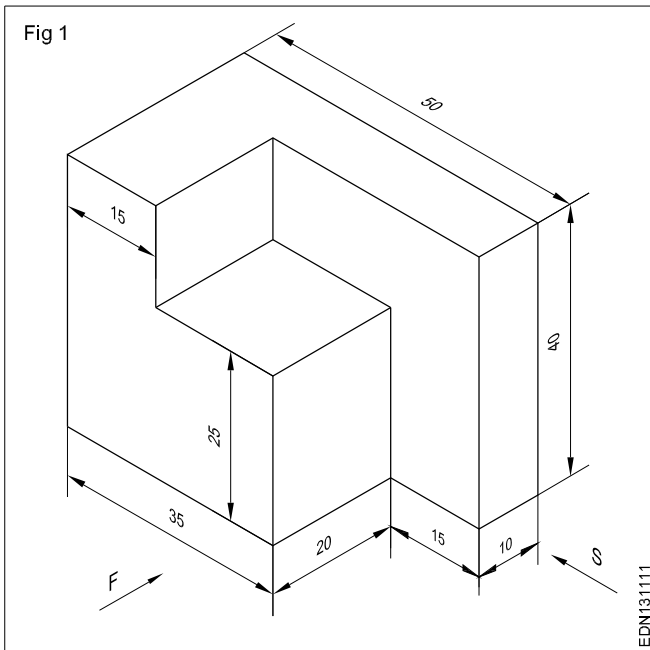

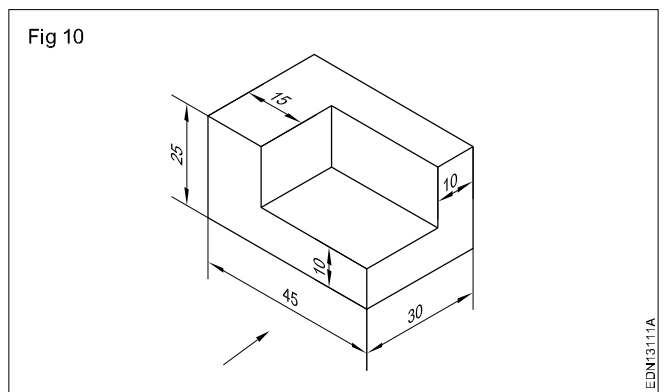
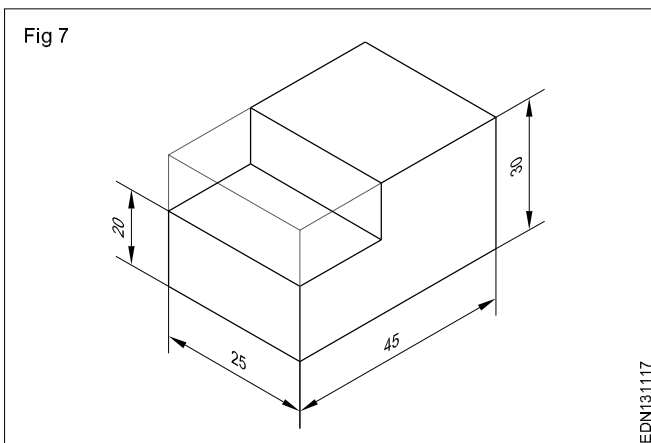
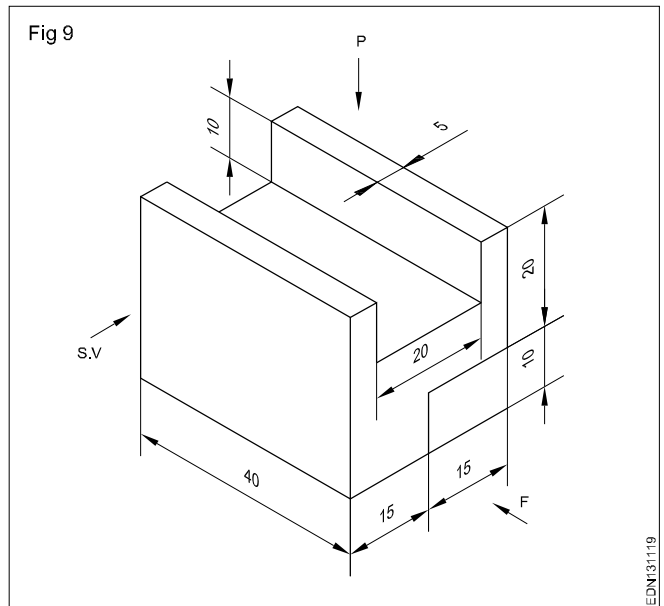
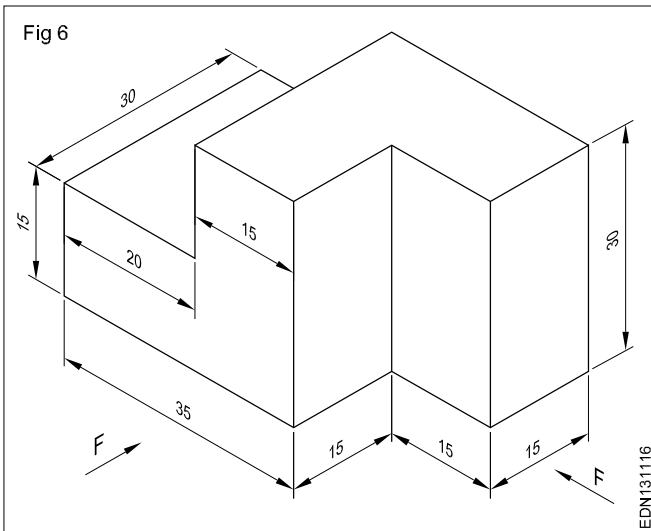
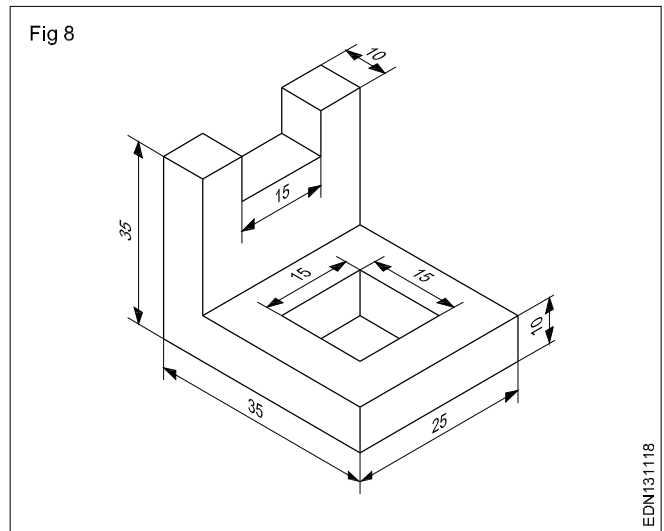
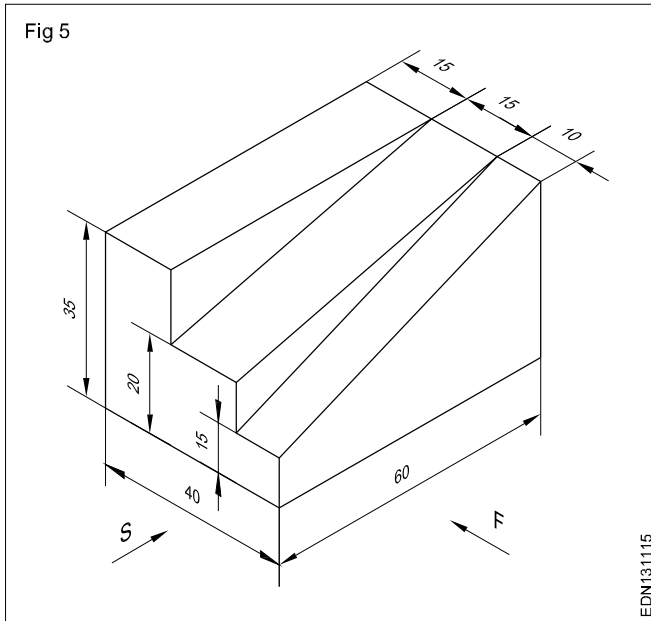



Transfer all the dimensions from the figures 1 to 10 of page nos.25 & 26 to the given objects below

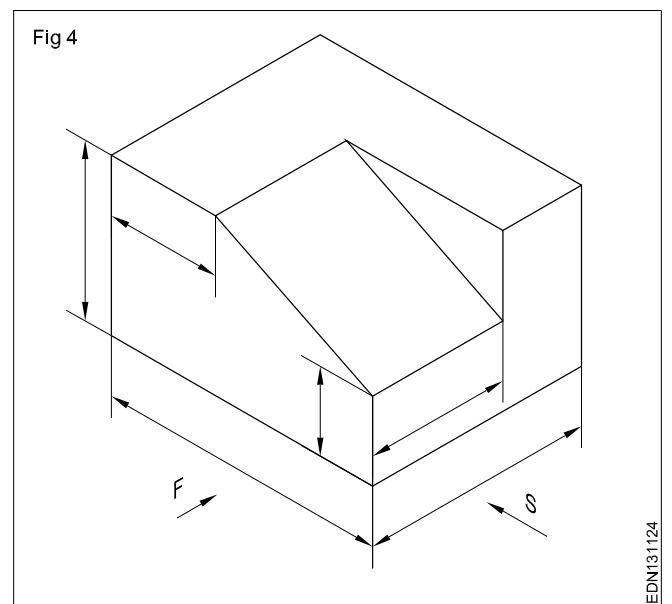
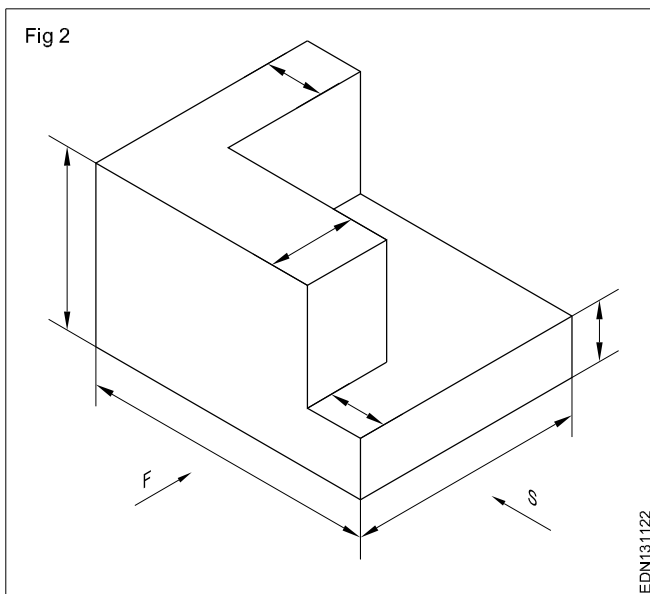
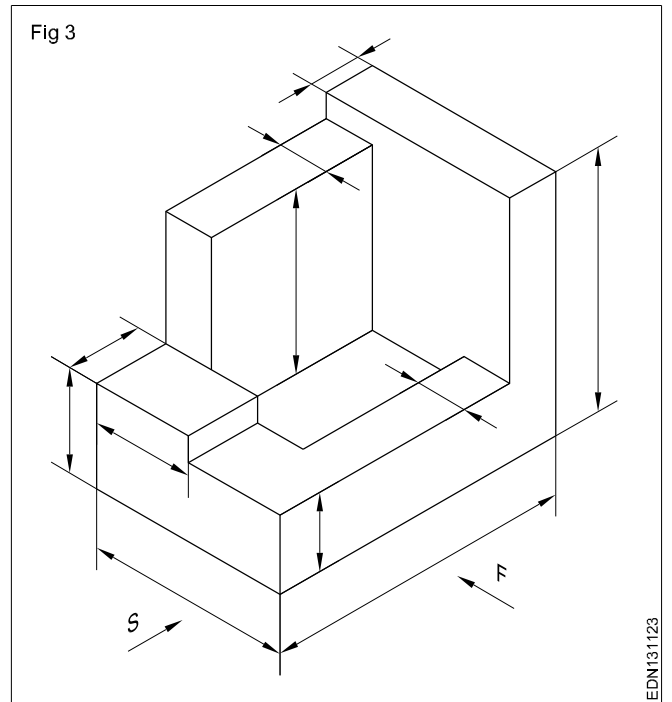
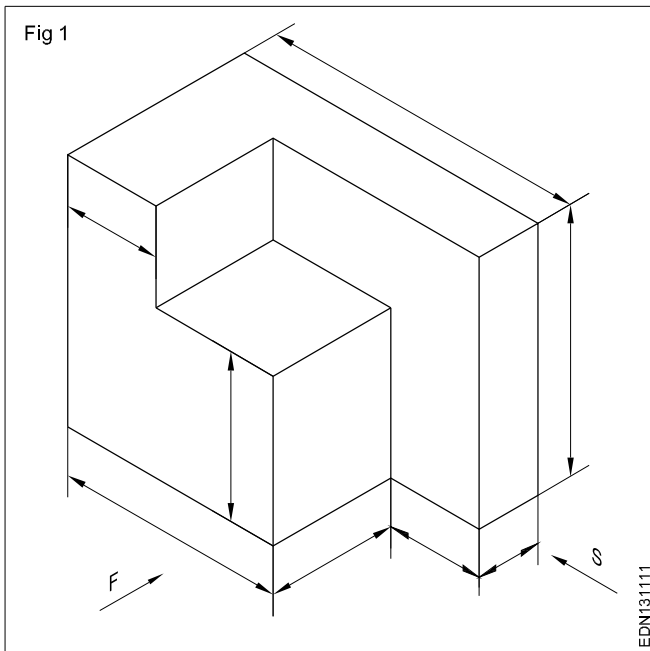
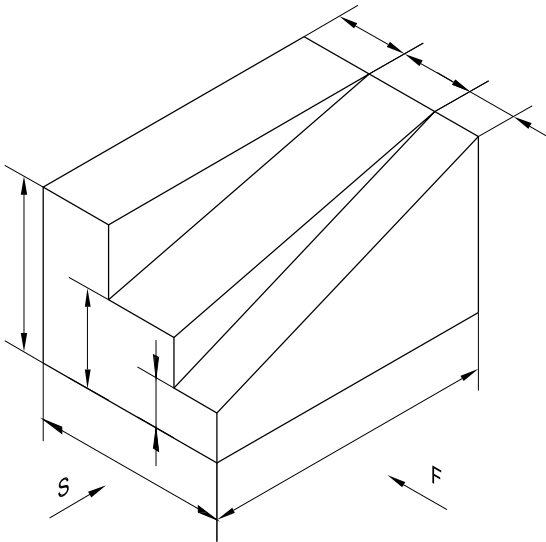
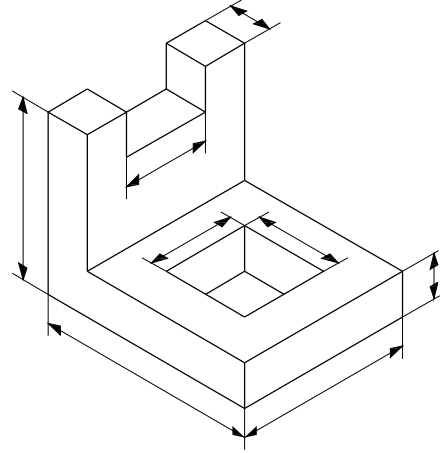

Fig 5



EDN131125

Fig 8



EDN131128

Fig 6

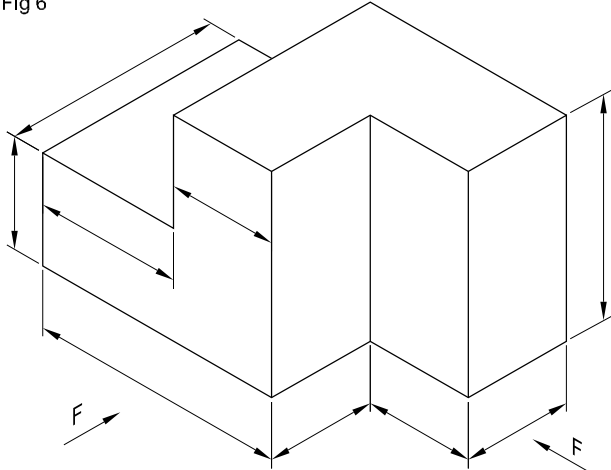

EDN131126

Fig 9

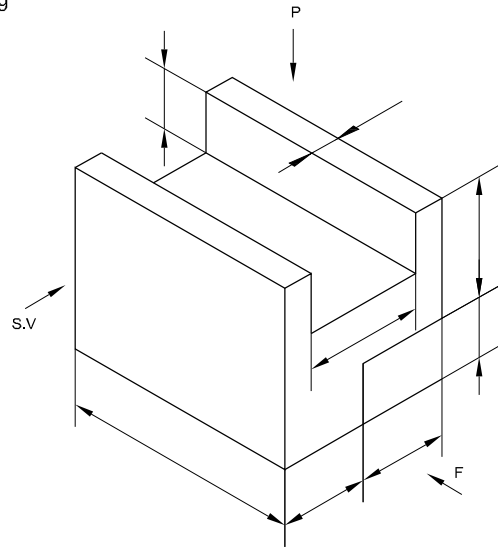

EDN131129

Fig 7

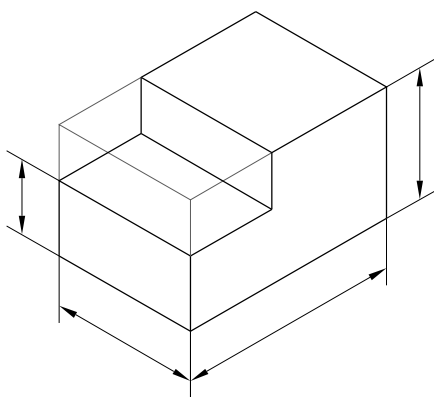

EDN131127

Fig 10

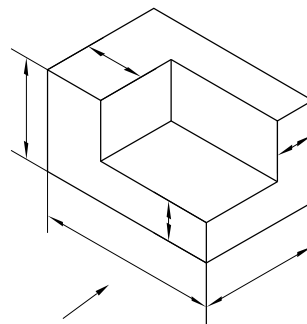

EDN13112A

**Free hand drawing of solid figures, cubes, cuboids, cone, prism, pyramid, frustum of cone with dimensions**

**Cube (Fig 1)**

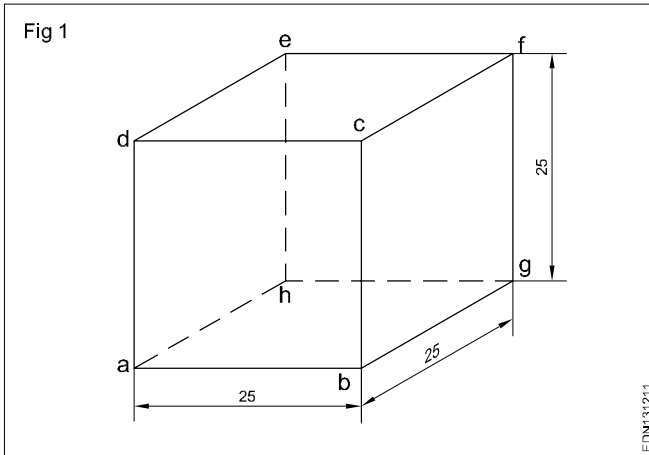

- Draw square of a, b, c and d.
- Draw 30° lines from point b, c and d for the length of 25mm.
- Mark point g from b, f from c and e from d as shown in figure.
- Joint all points.

**Cuboid (Fig 2)**

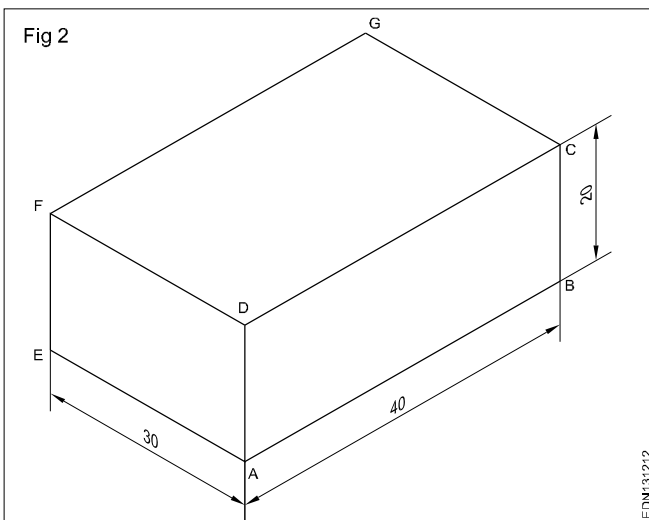

Draw the isometric drawing of a cuboid of base 30 mm x 40 mm and the height 20 mm. (Fig 2)

Draw the three isometric axes through point 'A'.

- Mark AB = 40mm, AE = 30mm and AD = 20mm representing the three sides of cuboid.
- Draw two vertical lines parallel to the line EF and BC from point E and B respectively.

- Similarly draw two more lines parallel to AB and AE mark G interesting point from F and C.
- Draw lines parallel to DC and FG Draw lines parallel to DF and GC.
- Join all the points.

**Cylinder (Fig 3)**

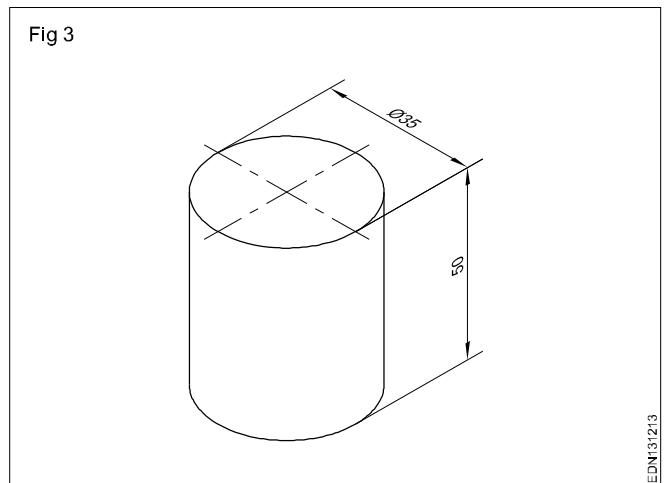

**Rectangular prism (Fig 4)**

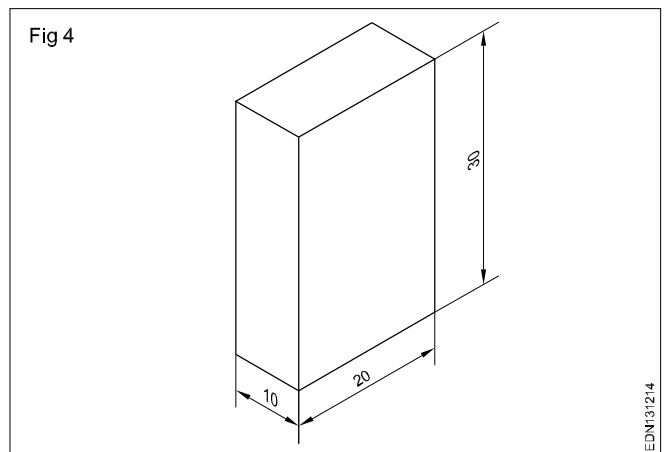

**Square Prism (Fig 5)**

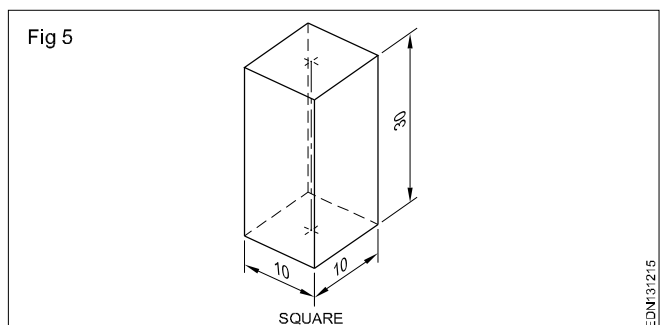

### Triangular Prism (Fig 6)

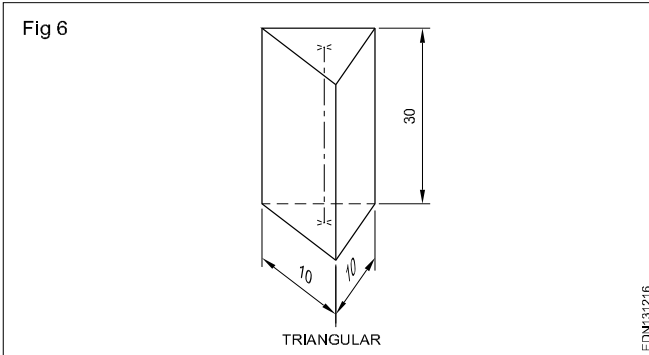

### Pentagonal prism (Fig 7)

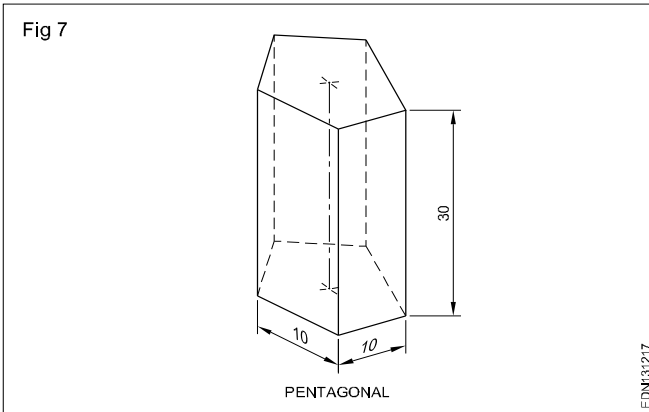

### Hexagonal prism (Fig 8)

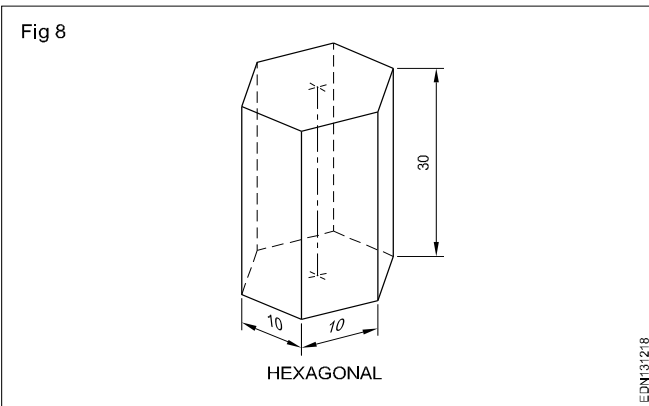

**Cone:** When a right angled triangle revolves about one of its side forming the right angle, a cone is generated. Cone forming has a circular face and a slant curved surface. (Fig9)

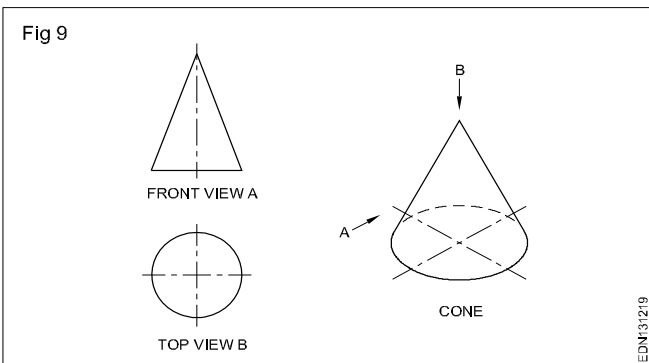

**Pyramids:** Pyramids are polyhedron solids having a base surface whose shape may be triangular, square or polygon and as many slant triangular faces as there are sides in the

base. All the slant triangular faces join at a common point called APEX.

Similar to prisms, pyramids also are known by the shape of their base viz triangular, square, rectangular, pentagonal, hexagonal etc. The imaginary line joining the centre of the base to the apex is called the AXIS.

Fig 10 shows some pyramids and their views.

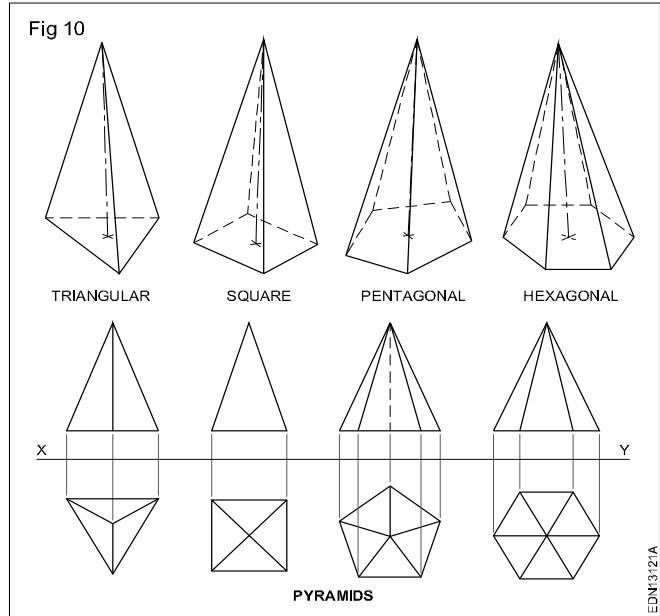

When a semi-circle revolves about its diameter a sphere is generated. A sphere has no flat surface. (Fig 11D)

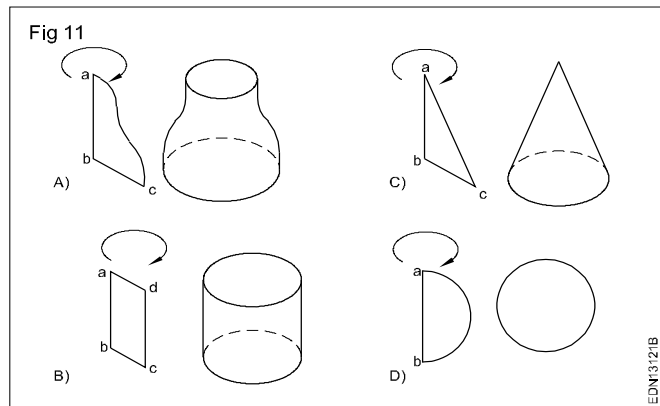

The term solids of revolution is a mathematical concept and a physical requirement in geometry.

**Frustums:** Pyramid/cone is cut parallel to the base and the top portion is removed. The remaining bottom portion is called frustum of a pyramid/cone.

If the cutting plane is at an angle to the axis/base, of the pyramids or cone they are called "Truncated pyramids or cones".

Fig 12&13 shows frustums and truncated pyramids.

All items we use are solids. Their shapes may confirm to individual geometrical solids like prisms, cones or other combination.

Figure 13 shows some items.

Draw the isometric view of a cone whose base diameter 40 mm and height 60 mm when its base rest on horizontal plain surface. (Fig 14)

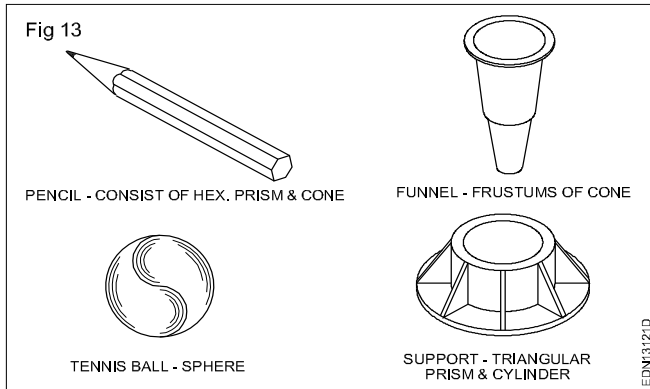
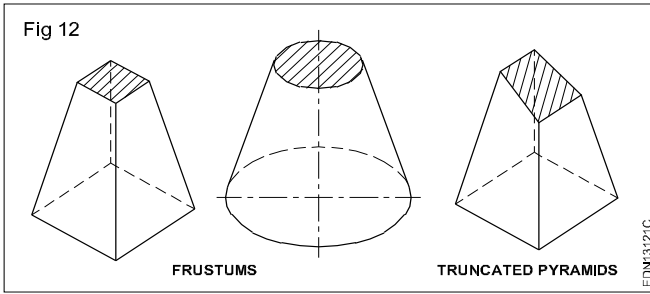

- Draw the front view and top view of the cone in the true scale as shown in the Fig 14a.

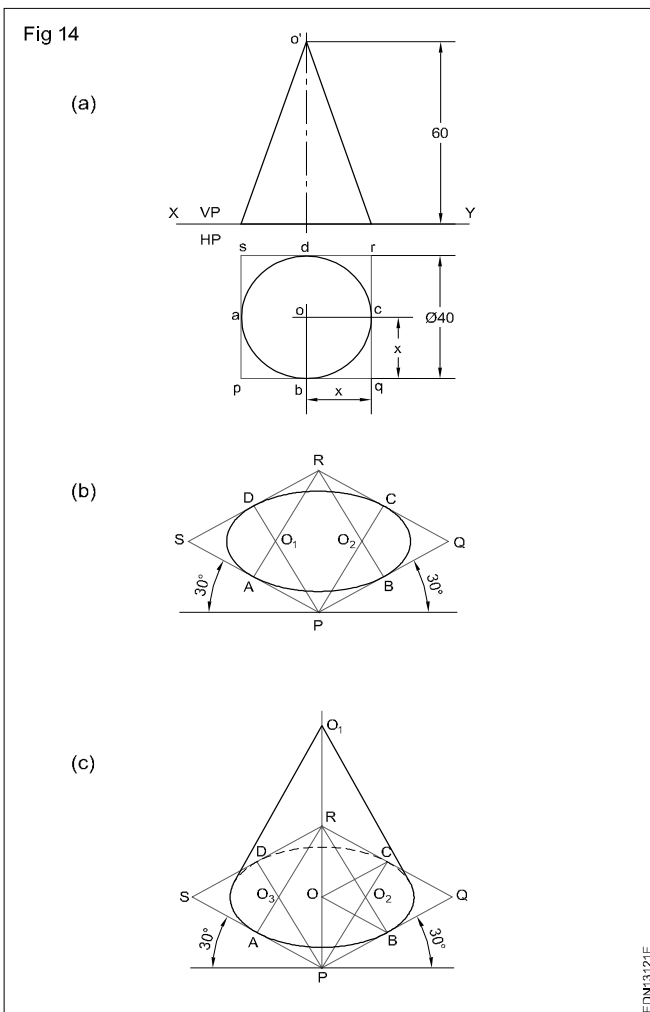

- Draw the isometric view of the base circle, (by four centre method) (Fig 14b)
- Mark the centre and draw vertical line  $0.0_1$  such that  $0.0_1$  equals to 60 mm in isometric scale.

- From 'O' draw tangents to the isometric circle of the base and complete the required isometric view of the cone. (Fig 14c)

Draw the isometric views of a hexagonal pyramid of side base 30 mm and height 75 mm given its position as under:

- Its base resting on HP and the edge of the base parallel to VP. (Fig 15)

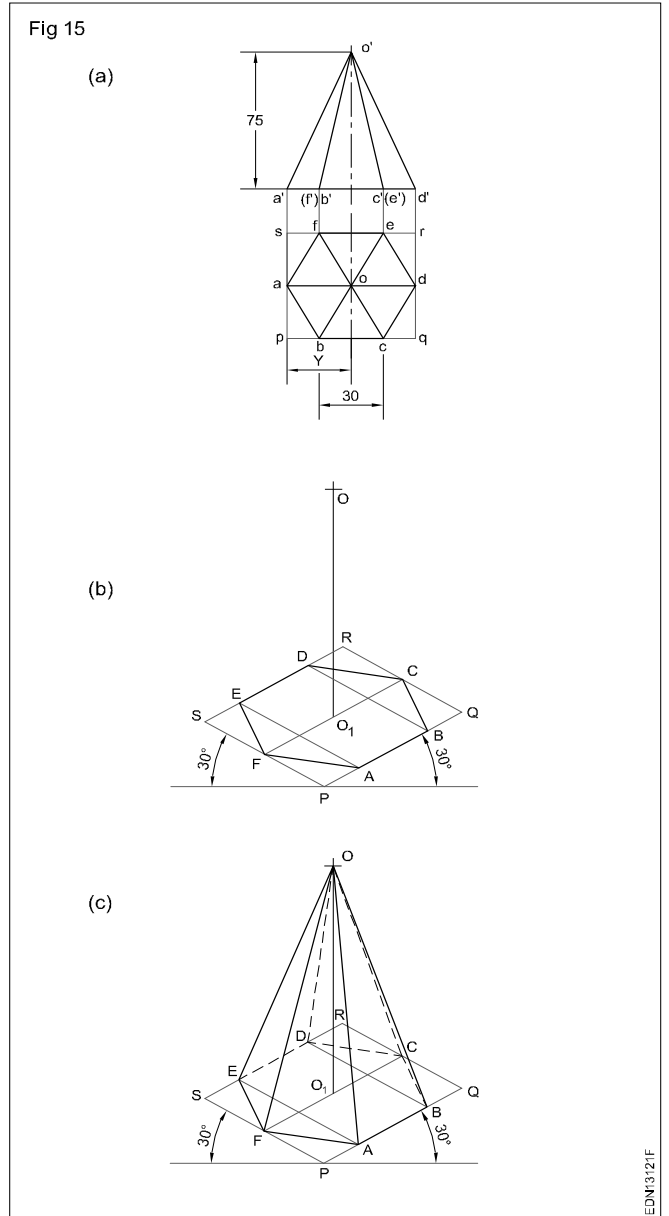

- Draw the top view and front view of the pyramid (true scale) and enclose the top view in the rectangle PQRS. (Fig 15a)
- Draw the parallelogram with two of its adjacent edges at  $30^\circ$  to the horizontal. (Fig 15b)  $PQ$  = Isometric length of  $pq$  and  $PS$  = Isometric length of  $PS$ .
- Draw an isometric hexagon ABCDEF in the parallelogram PQRS. (Fig 15b)
- Mark the centre 'O' and draw a vertical line from point 'O' of height to 75 mm in isometric scale.
- Join 'O' with ABCDEF to complete the required isometric projection of the hexagonal pyramid. (Fig 15c)

**Freehand drawing of hand tools and measuring tools used in common trades**

**Hand Tools**

Files (Fig 1)

- a Curved cut file
- b Rasp cut file
- c Single cut file
- d Double cut file

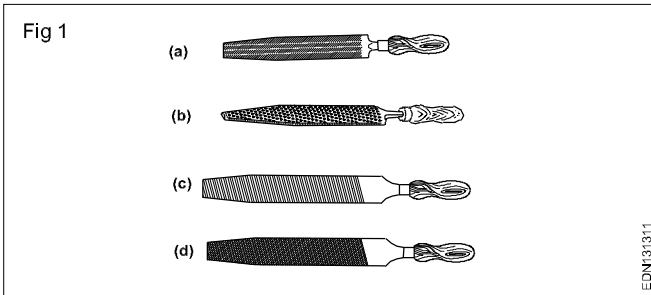

Scriber (Fig 2)

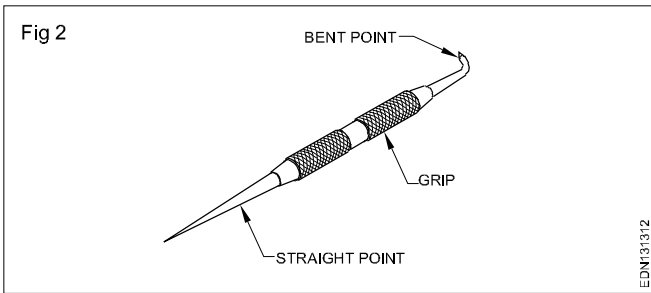

Divider (Fig 3)

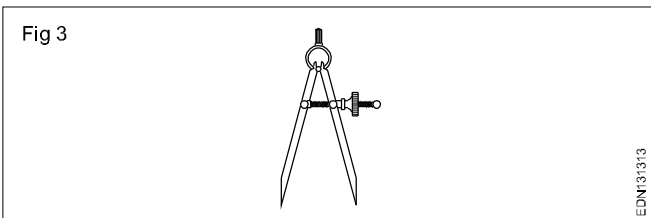

Outside caliper (Fig 4)

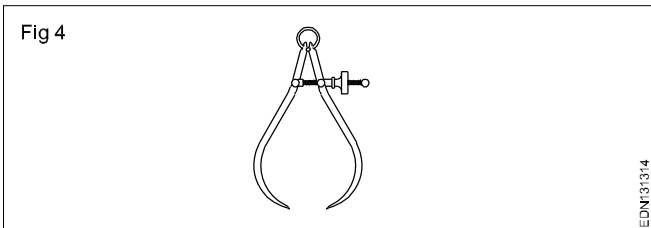

Inside caliper (Fig 5)

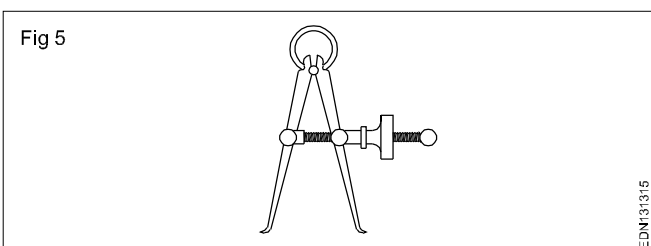

Hacksaw (Fig 6)

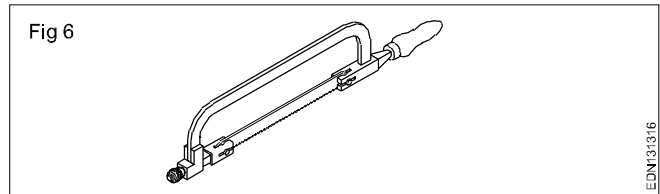

Ball pein hammer (Fig 7)

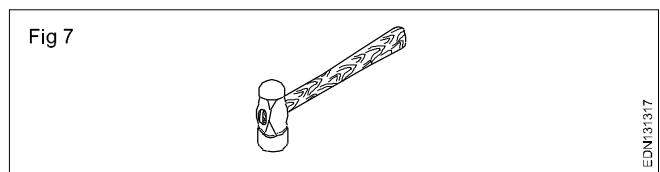

Chisel (Fig 8)

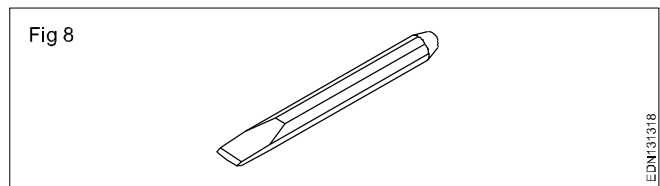

'C' clamp (Fig 9)

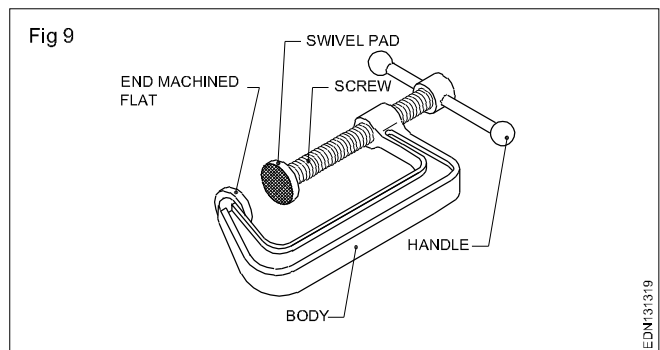

Screw driver (Fig 10)

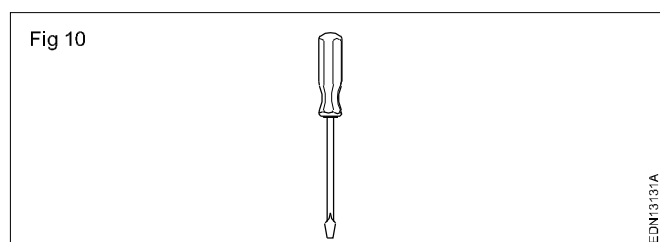

Bench vice (Fig 11)

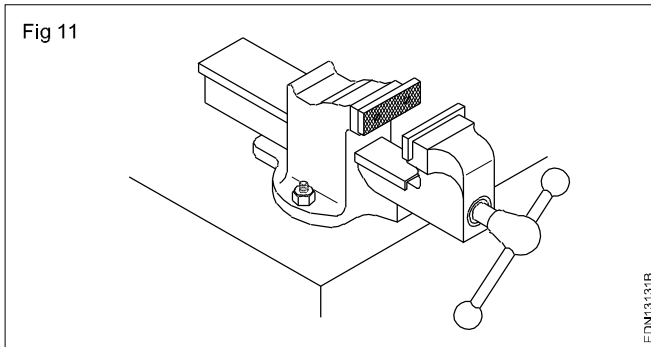

Centre punch (Fig 12)

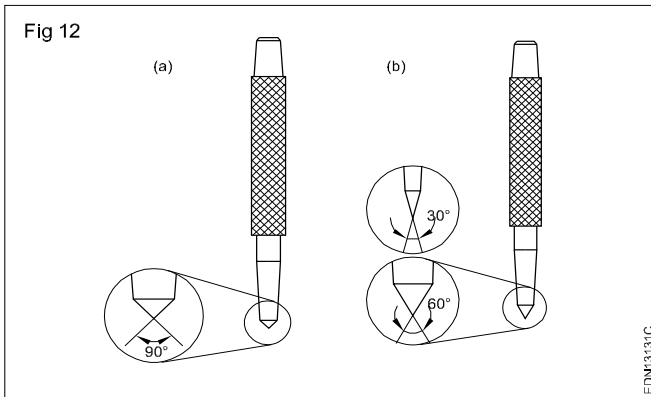

Cutting plier (Fig 13)

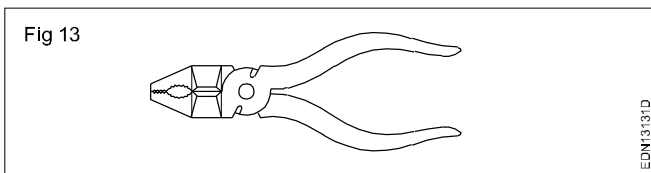

Open end spanner (Fig 14)

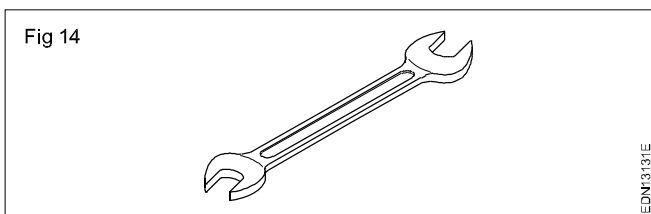

Marking gauge (Fig 15)

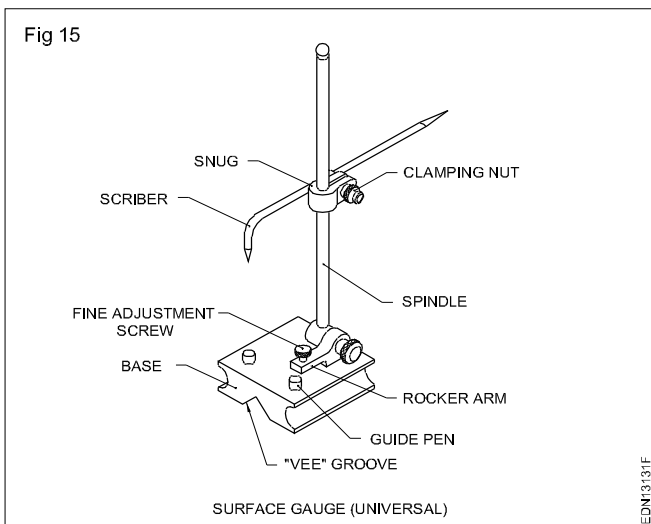

Hammers (Fig 16)

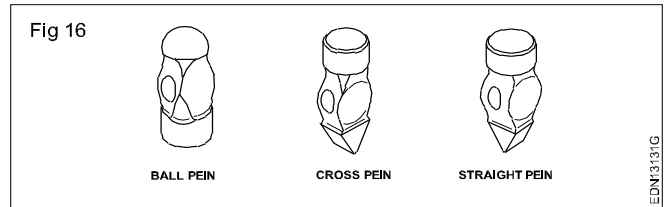

Measuring Tools

Steel rule (Fig 17)

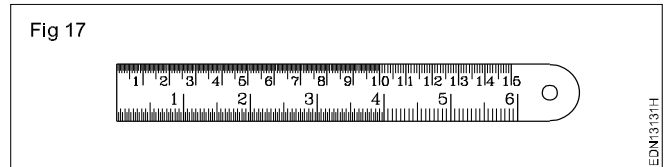

Try square (Fig 18)

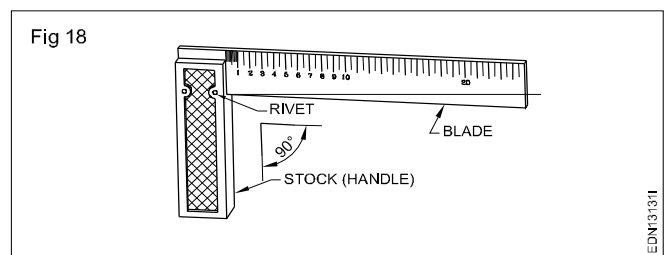

Vernier caliper (Fig 19)

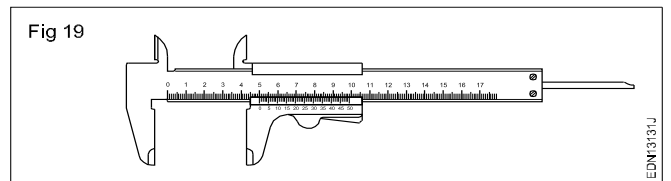

Micrometer (Fig 20)

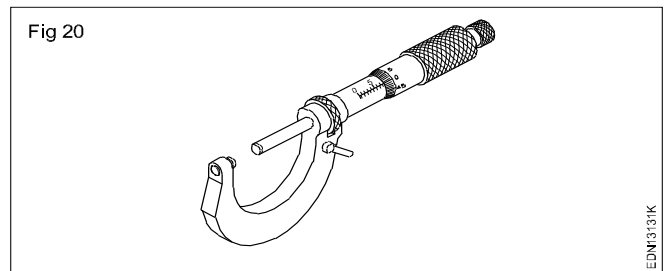

Vernier height gauge (Fig 21)

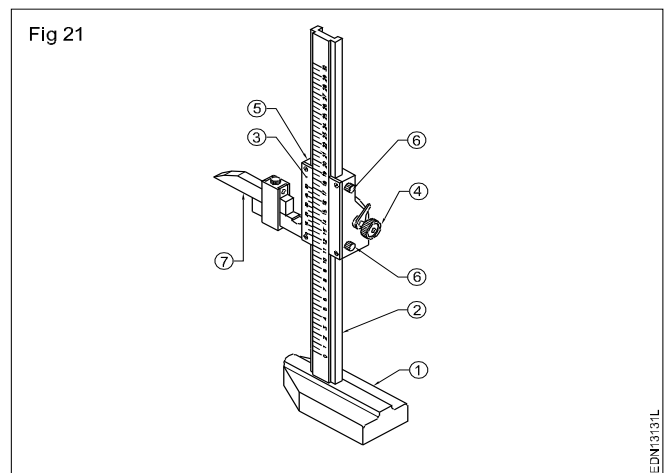

Feeler gauge (Fig 22)

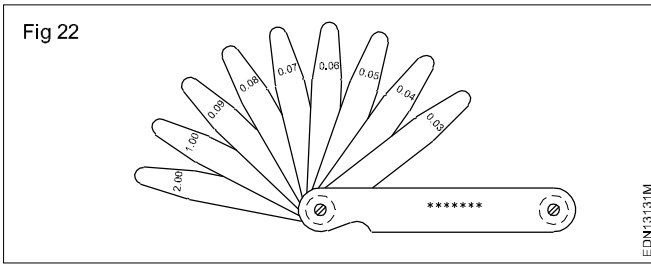

Bevel protractor (Fig 23)

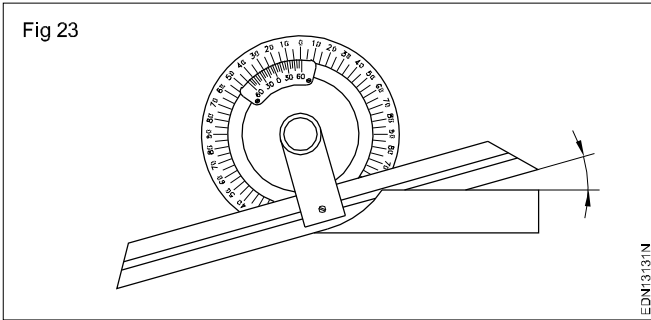

Slip gauge box (Fig 24)

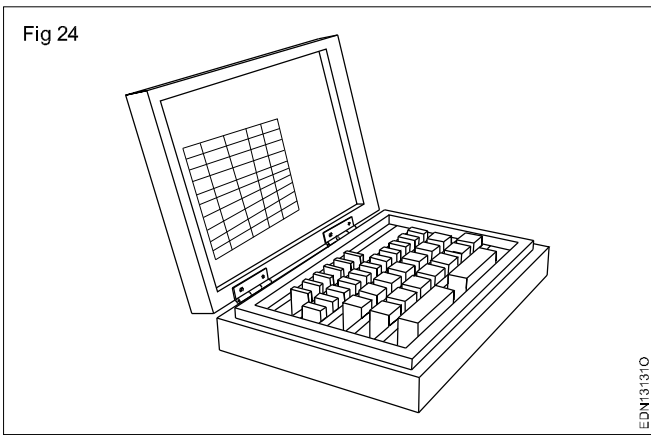

Sine bar with dial gauge (Fig 25)

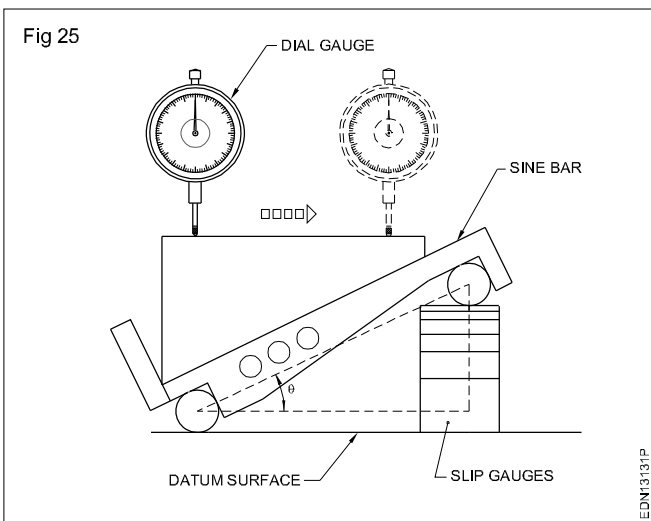

Combination set (Fig 26)

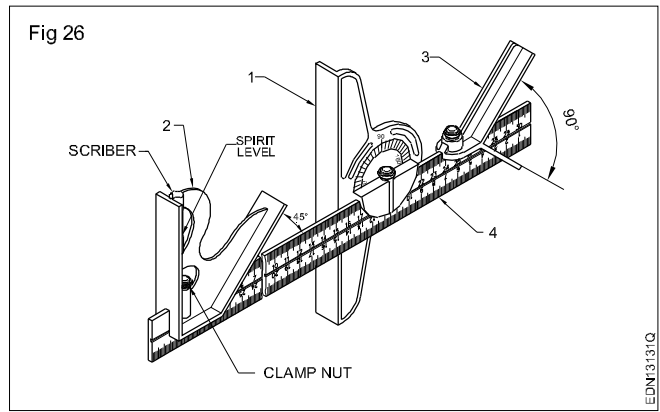

Vernier depth gauge (Fig 27)

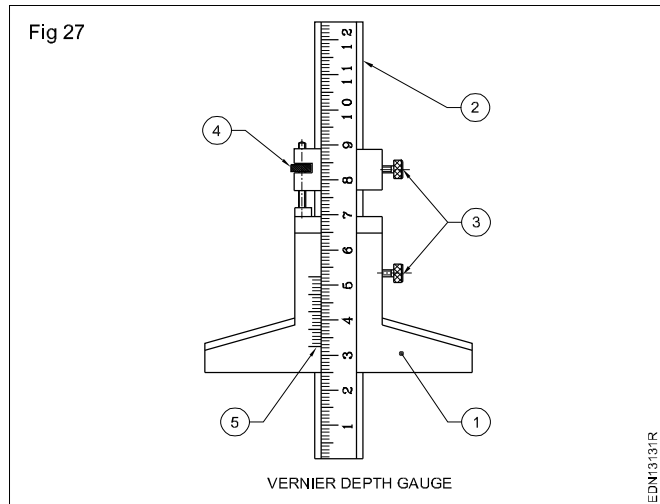

Depth micrometer (Fig 28)

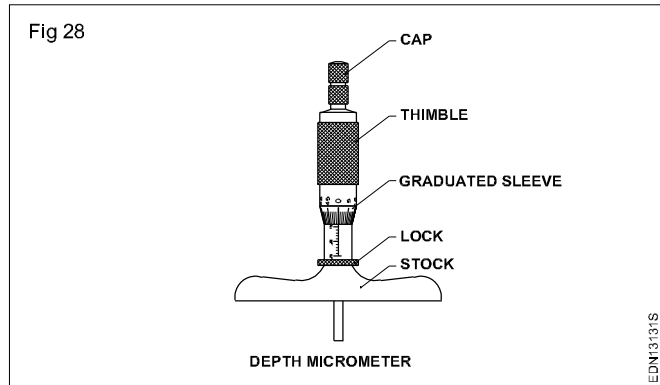



# Freehand drawing of hand tools and measuring tools used in electrician, electronics mechanic and wireman trades

Screw driver (Fig 1)

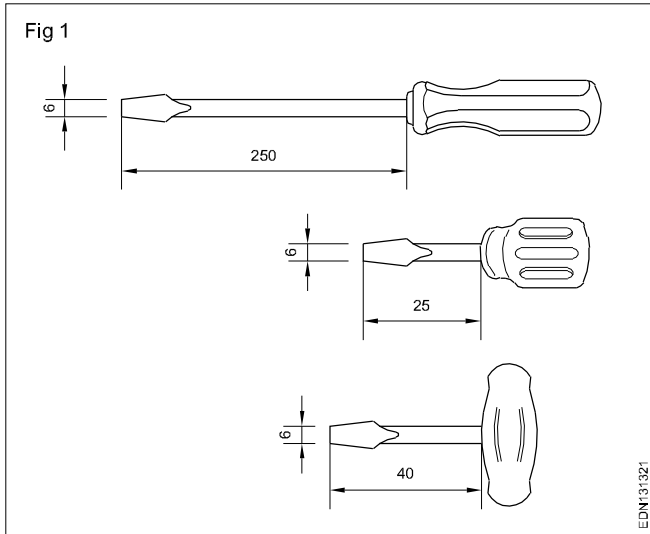

Instrument screw driver (Fig 4)

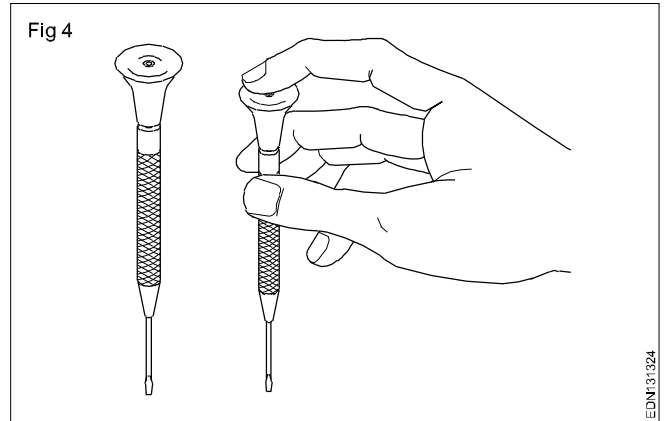

Screw driver with cross type tips (Fig 2)

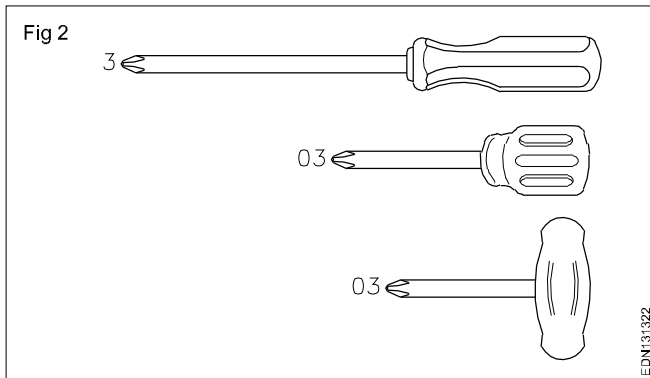

Screw driver interchangeable tips (Fig 5)

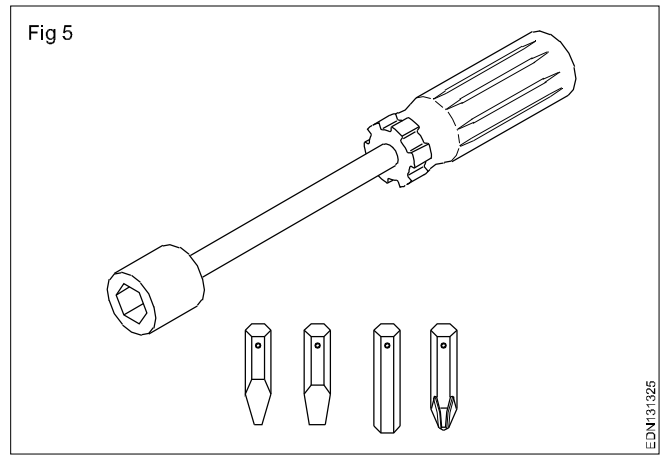

Screw tips aided screw heads (Fig 3)

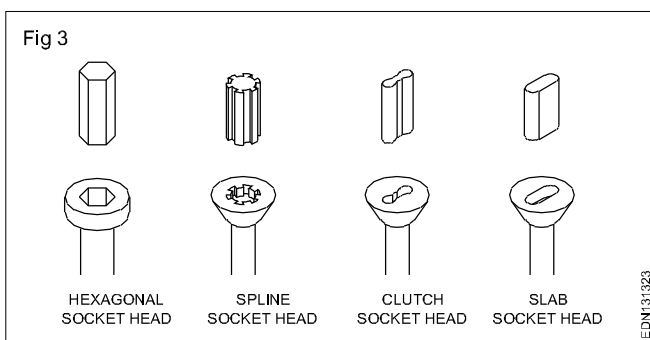

Special type screw driver (two rectangular recesses) (Fig 6)

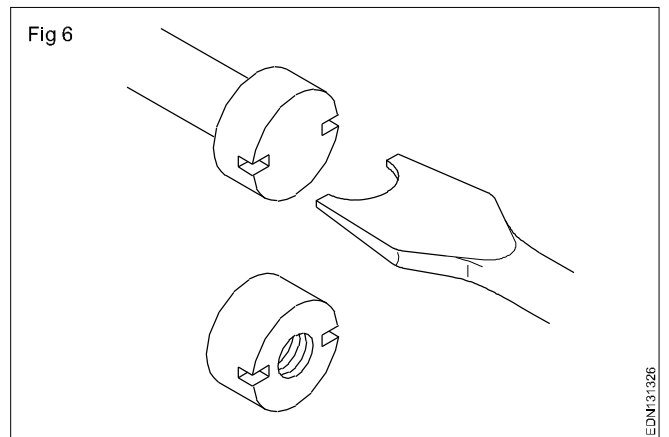

Special type screw driver (two round recesses) (Fig 7)

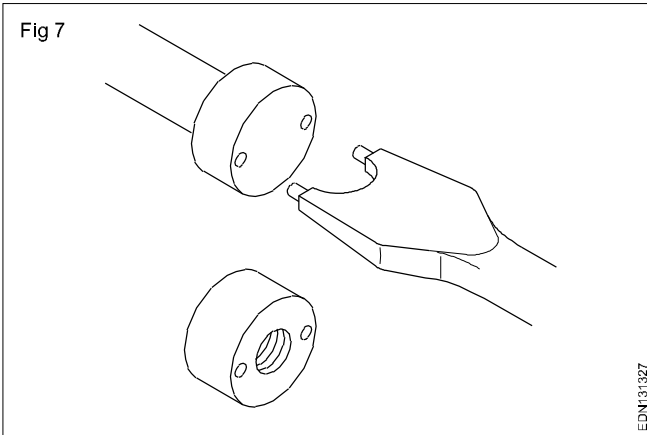

Pliers (Fig 8)

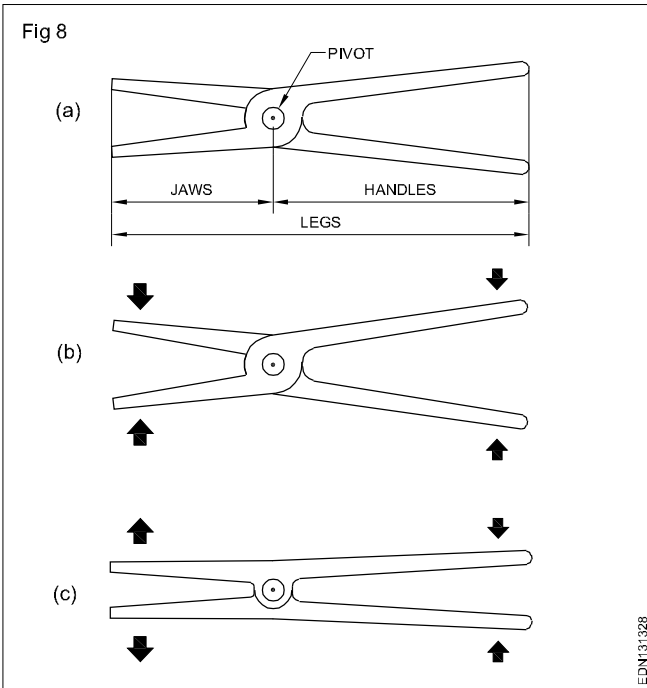

Analog multimeter (Fig 9)

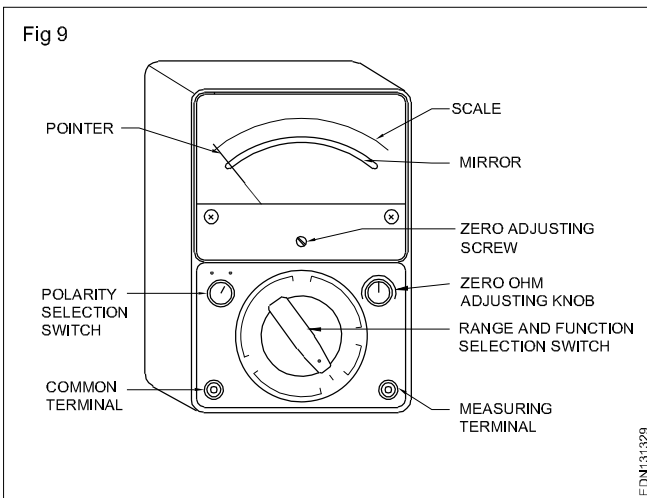

Melted solder blocking flux cores (Fig 10)

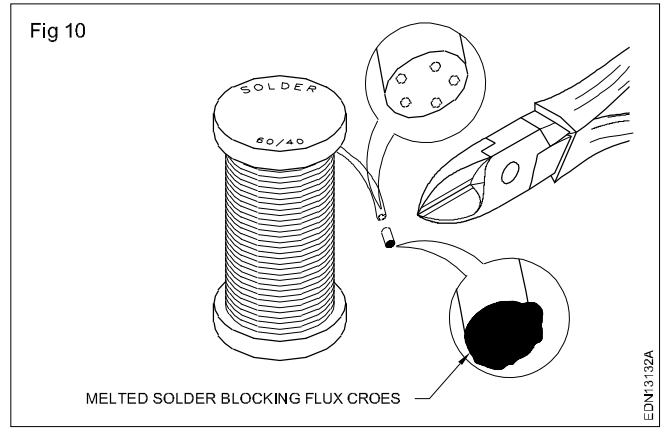

Soldering iron (Fig 11)

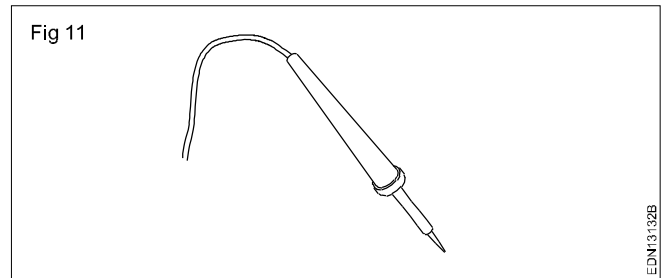

Ratchet brace (Fig 12)

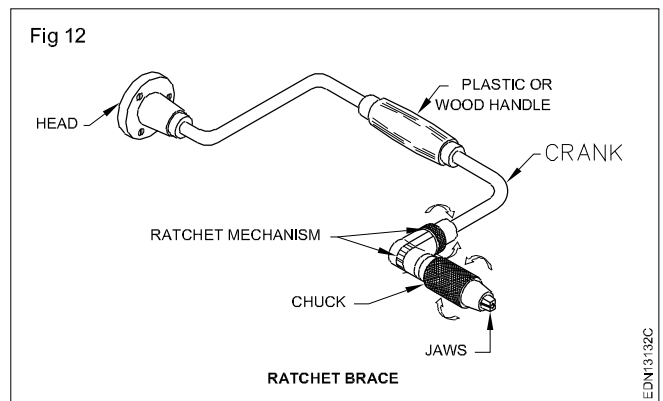

Neon Tester (Fig 13)

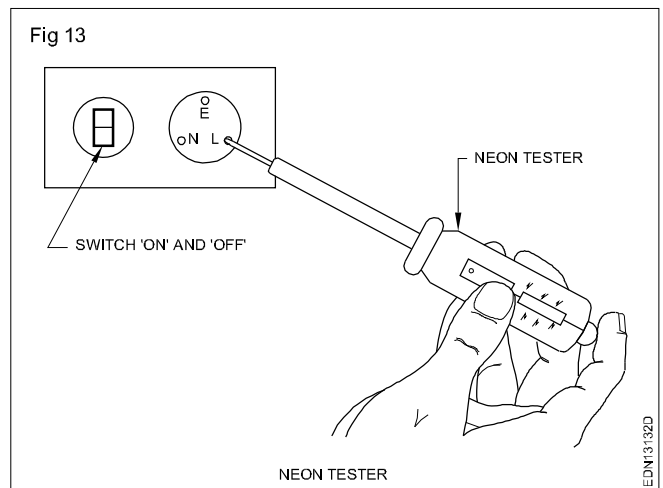

Gimlet (Fig 14)

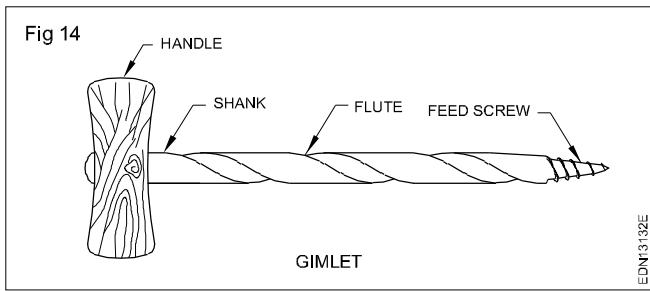

Bradawl & poker (Fig 15)

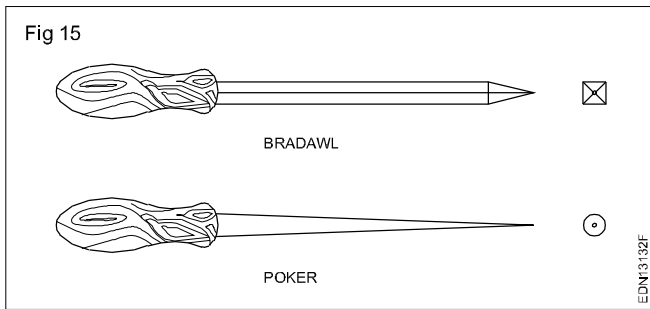

Electrician's knife (Fig 16)

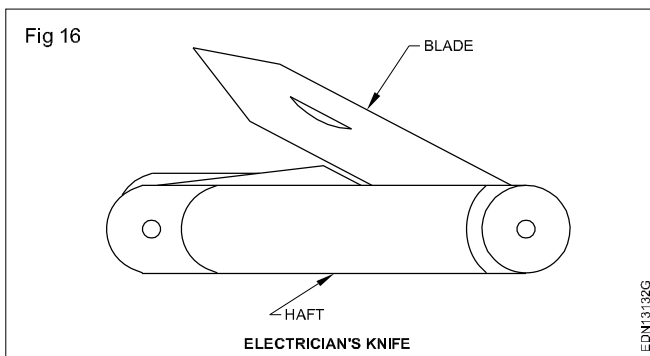

Mallet (Fig 17)

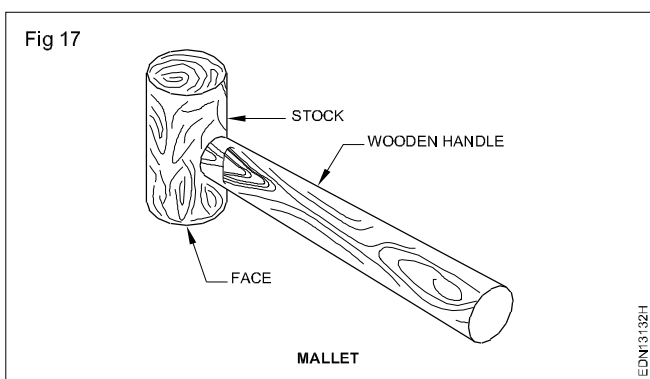

Electric drilling machine (Fig 18)

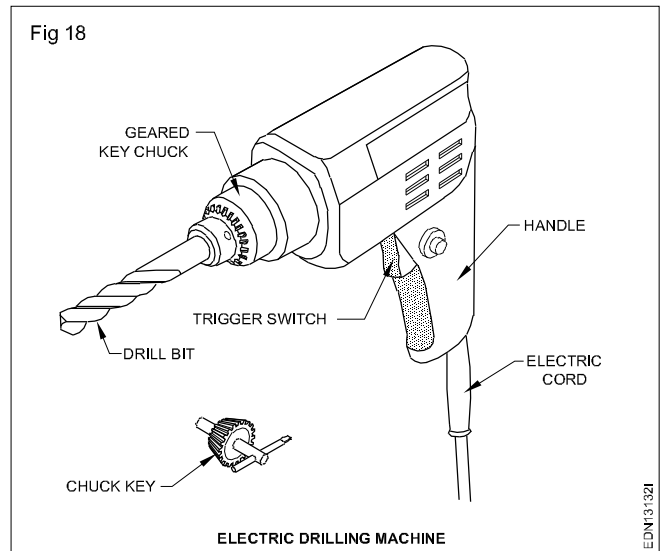

Hand drill (Fig 19)

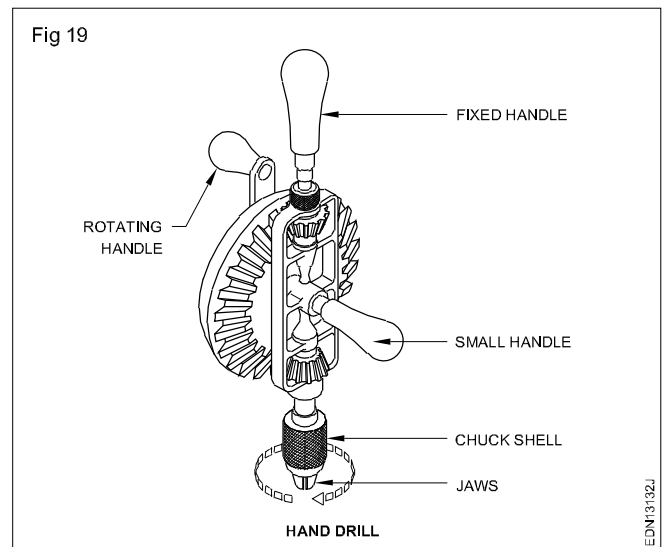

Rawl plug tool (Fig 20)

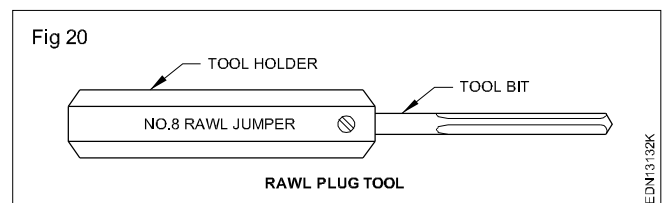

# Freehand drawing of hand tools and measuring tools used in mechanic motor vehicle and mechanic diesel trades

Spanners (Fig 1)

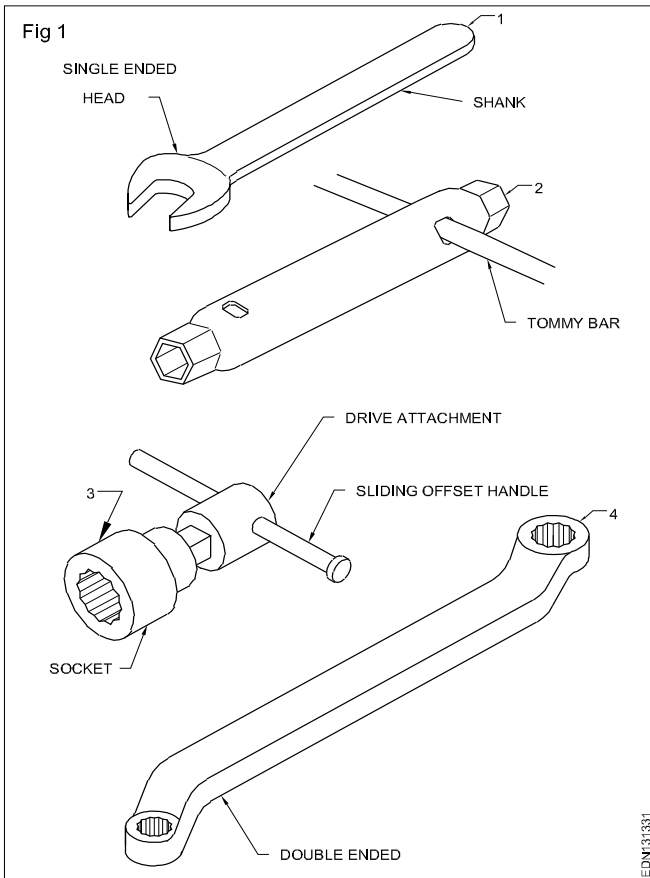

Sliding 'T' handle socket spanner (Fig 2)

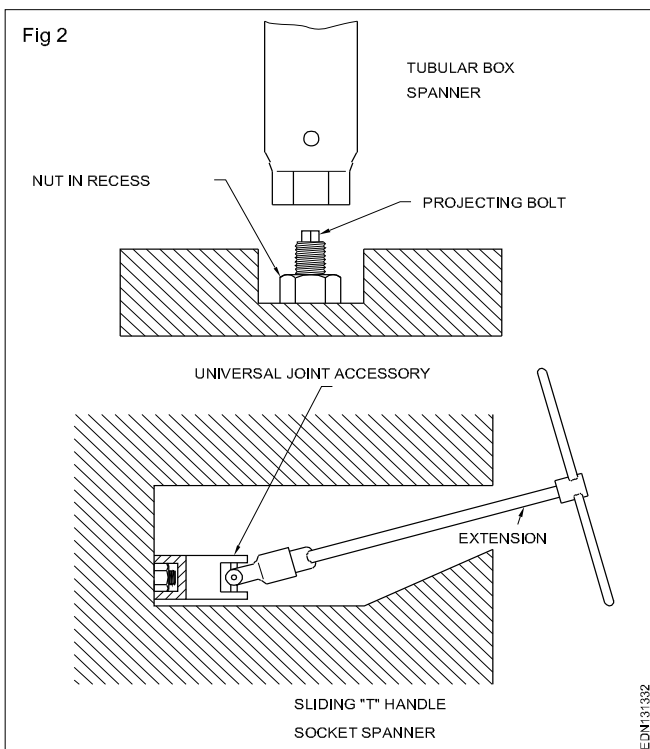

Adjustable spanner (Fig 3)

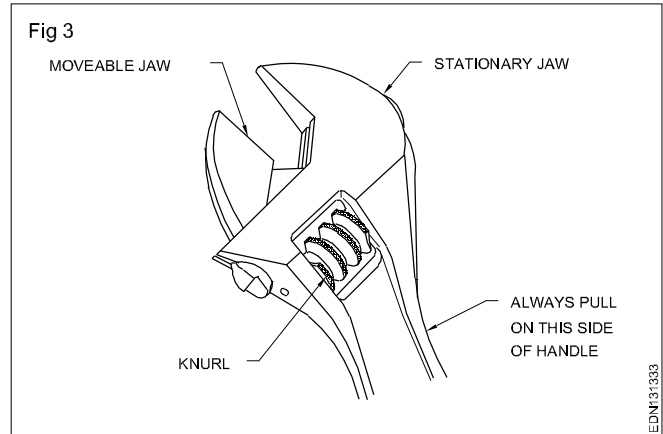

Socket spanner (Fig 4)

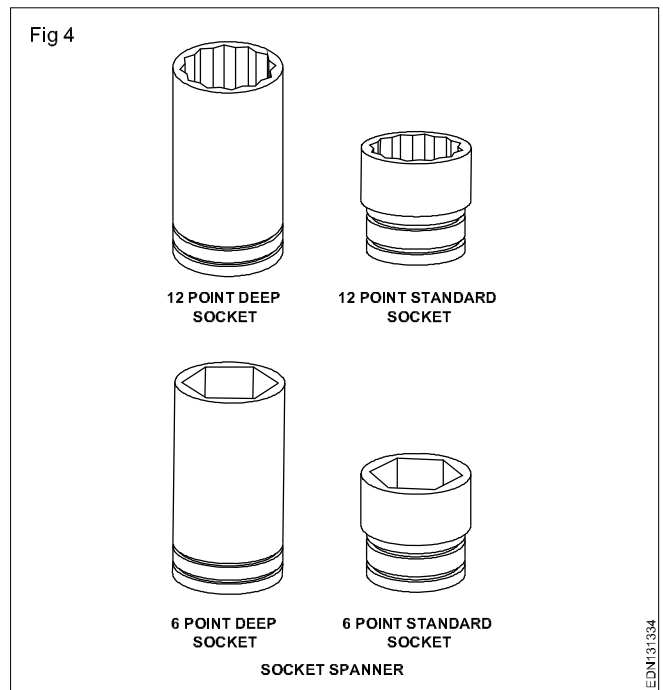

Pliers (Fig 5)

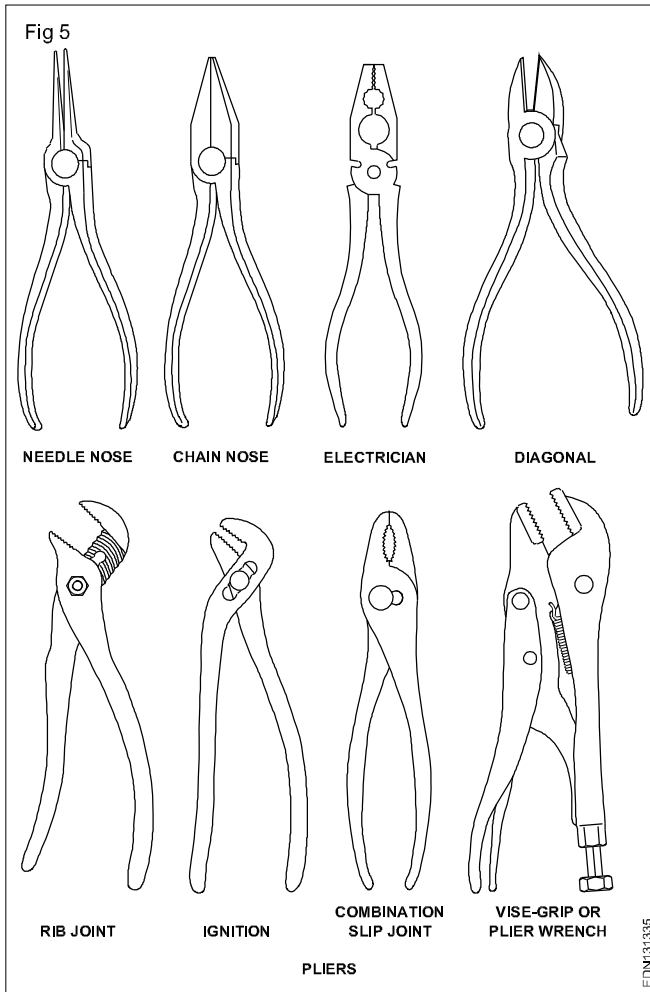

Cutting plier (Fig 6)

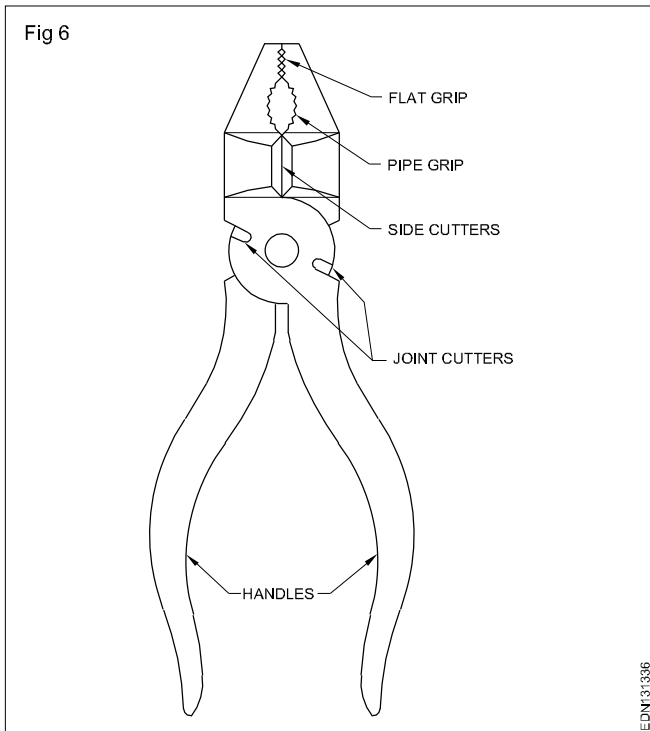

Socket extension bars (Fig 7)

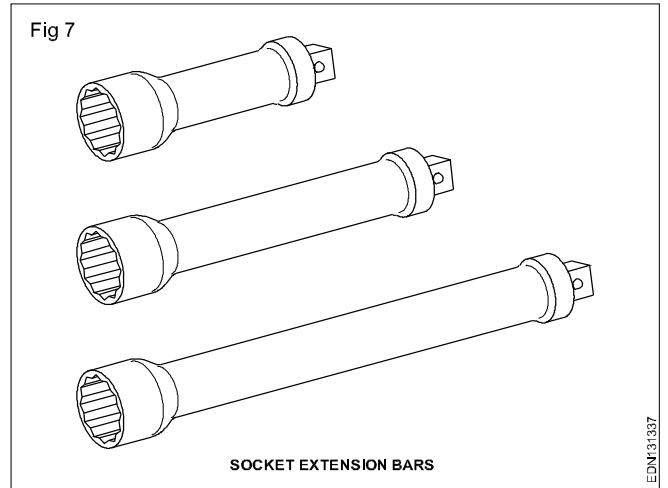

Round nose plier (Fig 8)

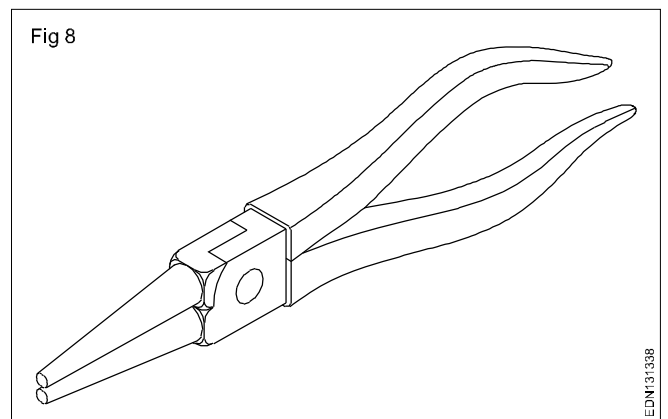

Stillson pipe wrench (Fig 9)

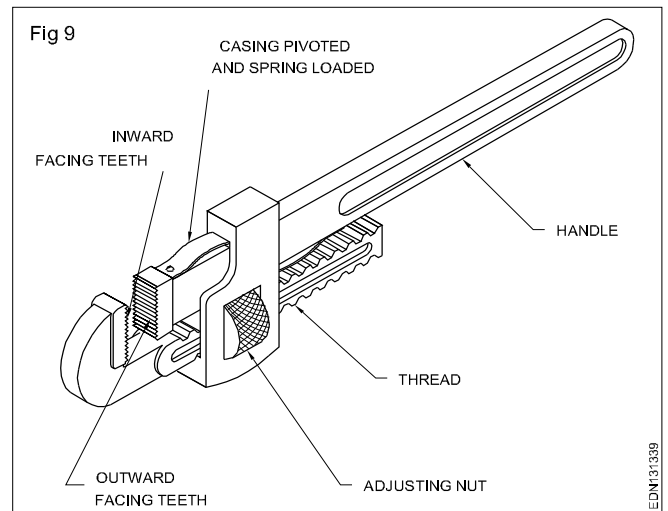

Pipe cutter (Fig 10)

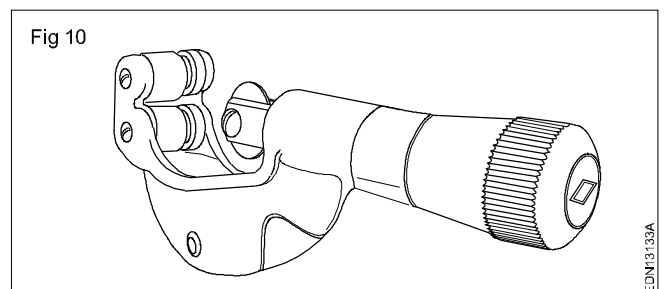

Puller (Fig 11)

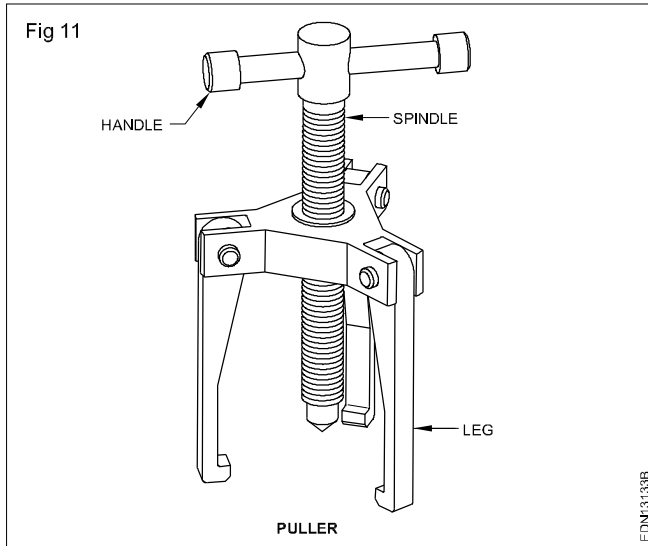

Piston ring expander (Fig 14)

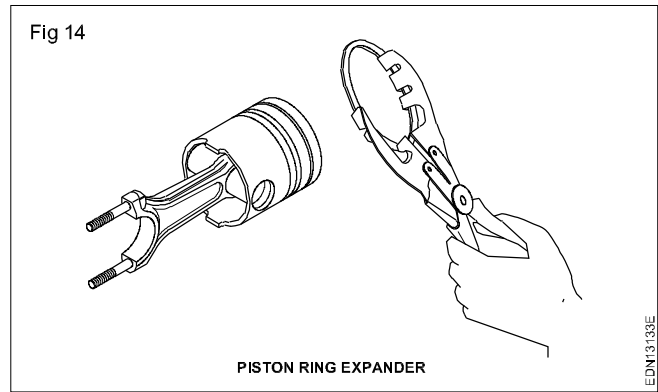

Valve spring compressor & valve grinder (Fig 12)

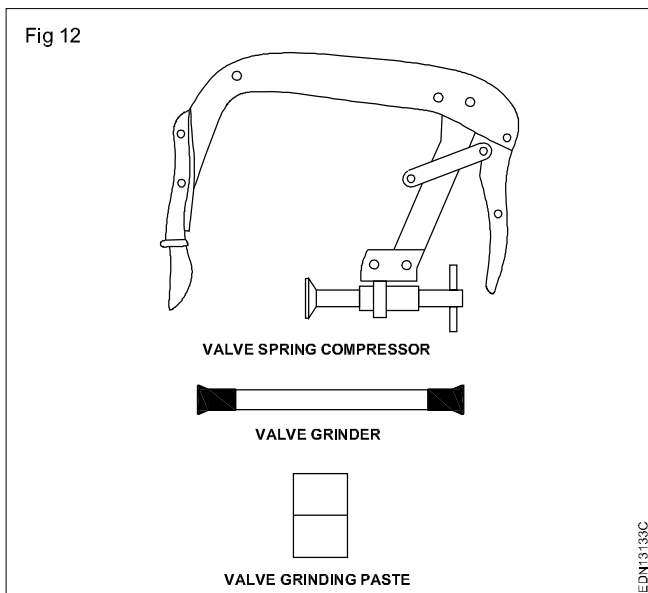

Testing valve spring tension (Fig 15)

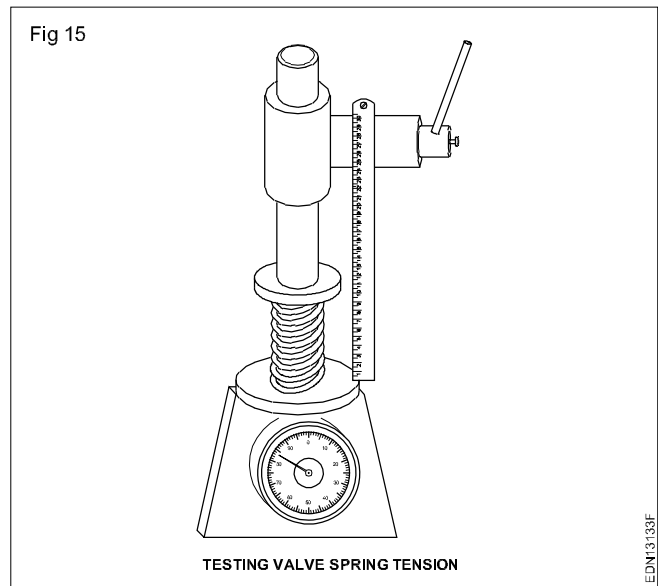

Connecting rod alignment fixture (Fig 16)

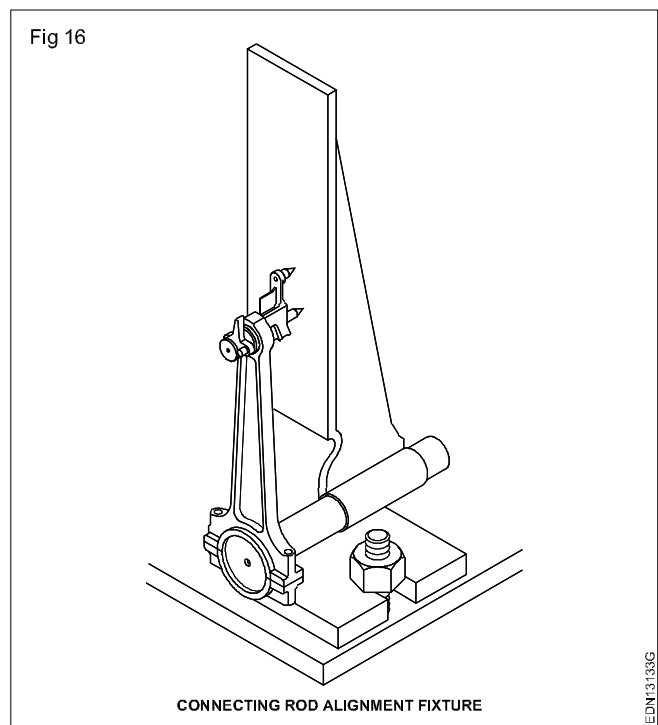

Wooden block & ring compressor (Fig 13)

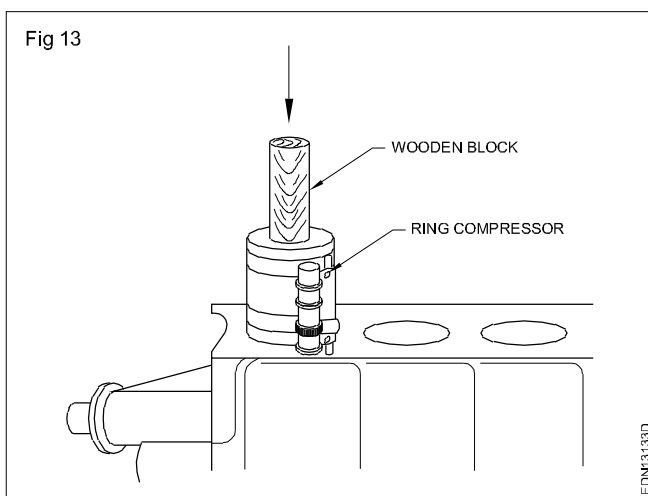

# Freehand drawing of hand tools and measuring tools used in plumber trade

Face wrench (Fig 1)

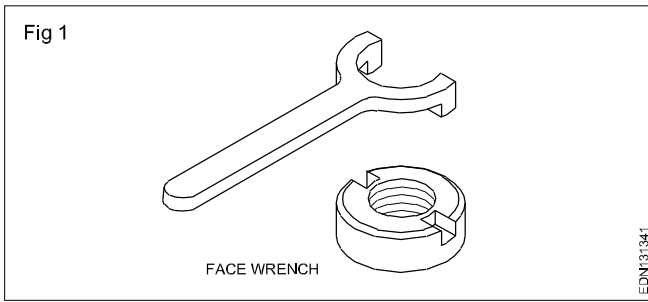

Mortar pan (Fig 5)

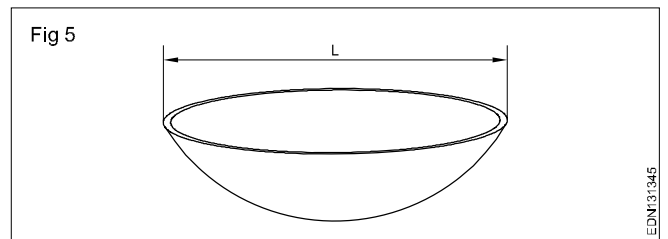

Hook wrench (Fig 2)

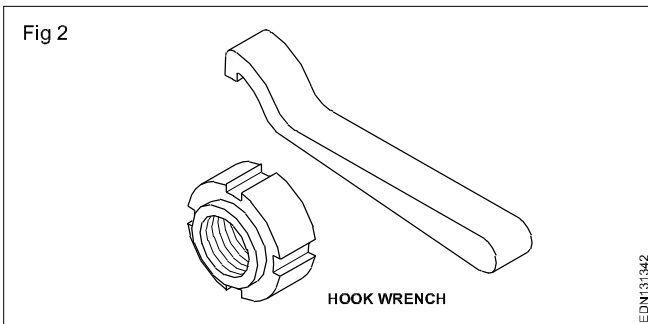

Bricklaying trowel (Fig 6)

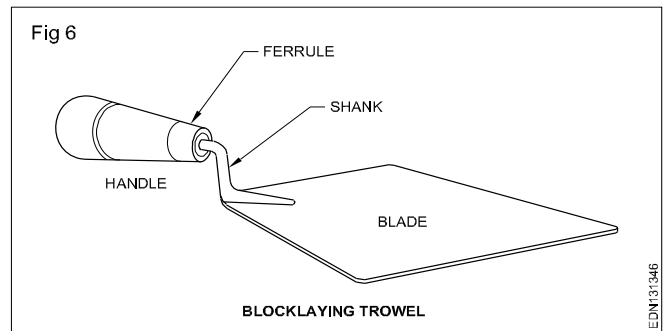

Spade (Fig 3)

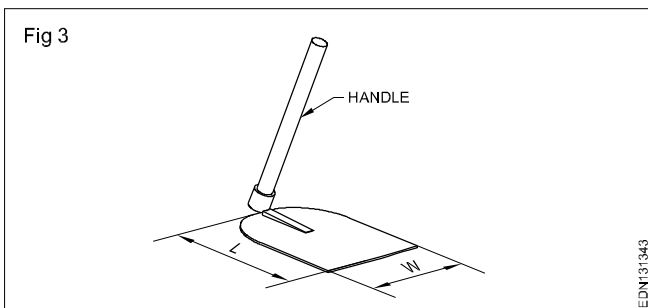

Jointing board (Fig 7)

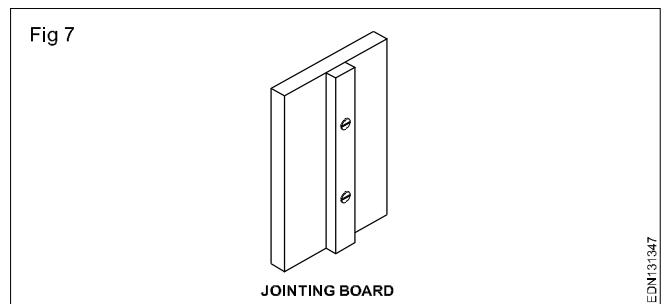

Pickaxe (Fig 4)

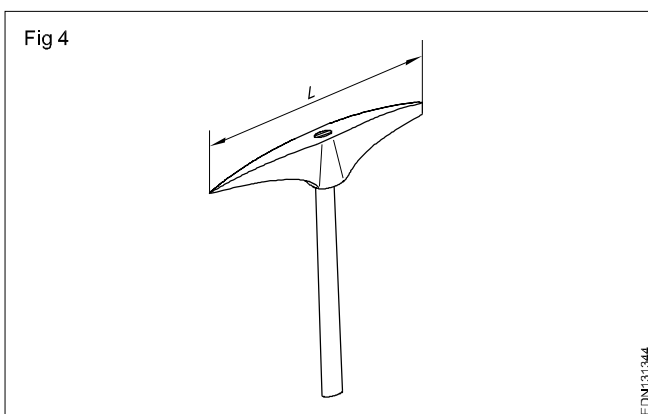

Steel square (Fig 8)

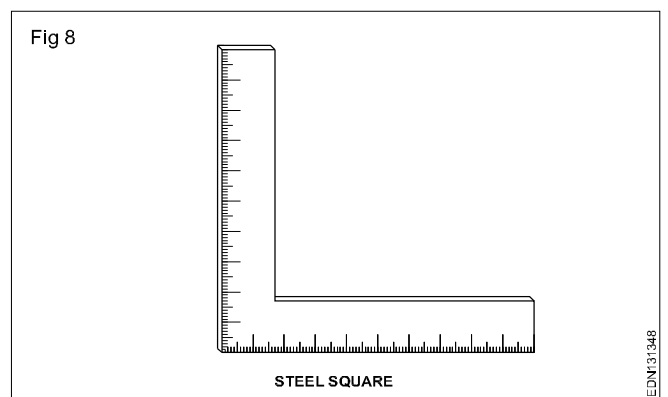

Spirit levels (Fig 9)

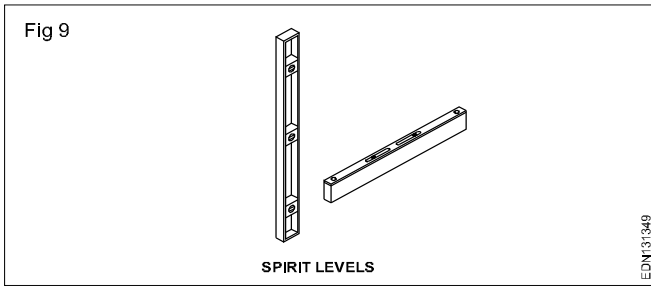

Line and pins (Fig 10)

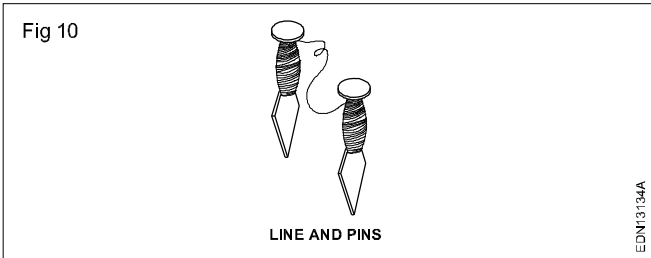

Square and bevel (Fig 11)

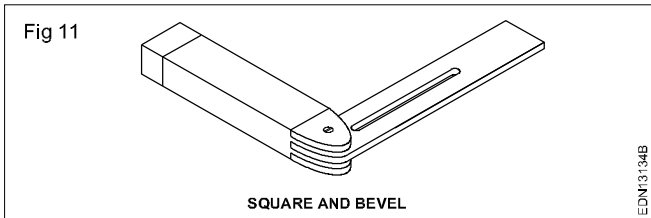

Gin wheel (Fig 12)



Pipe vice (Fig 13)

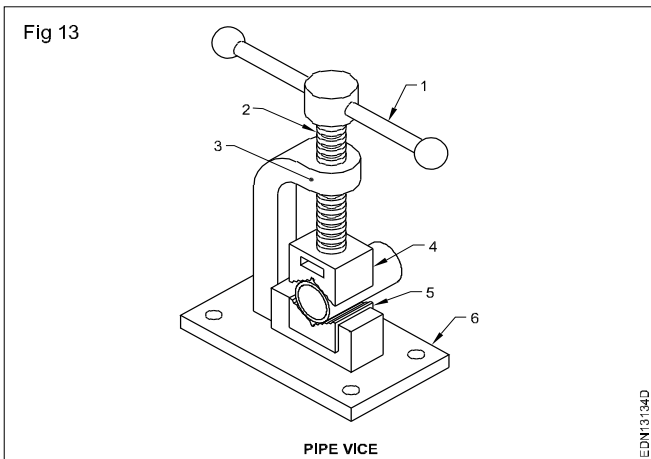

Chain pipe vice (Fig 14)

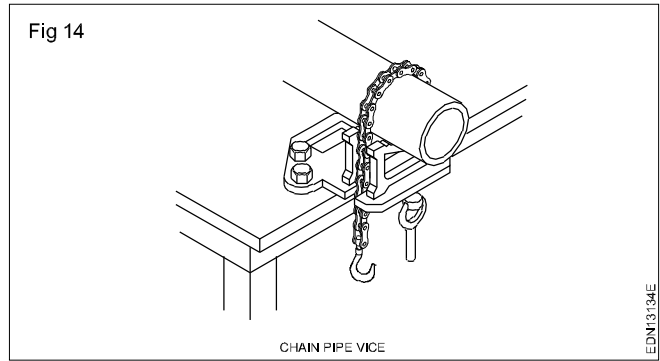

Pipe cutter (Fig 15)

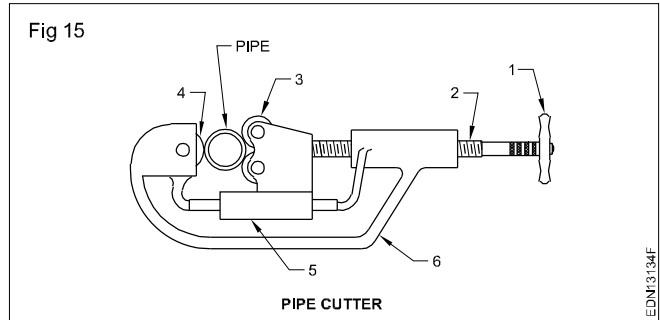

Multi wheel chain pipe cutter (Fig 16)

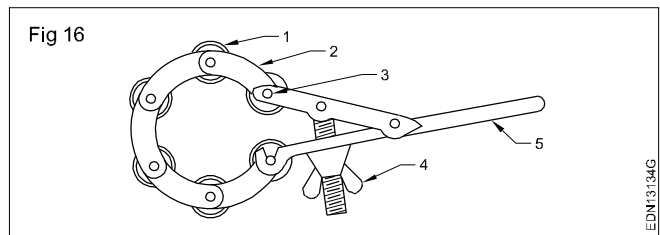

Accurate tube bender (Fig 17)

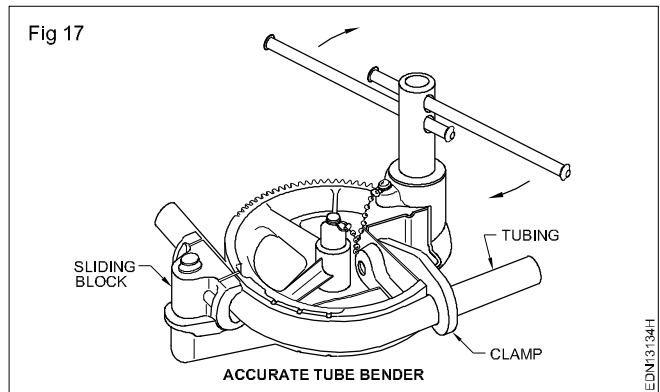

Pinch-off tool (Fig 18)

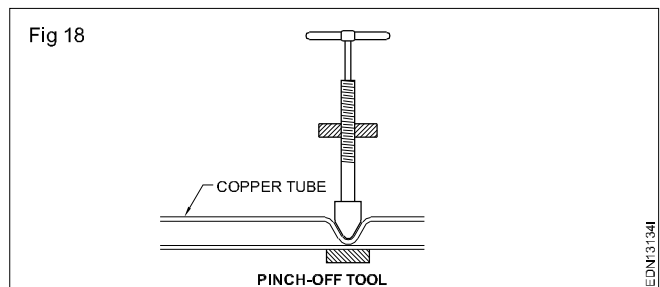



# Freehand drawing of hand tools and measuring tools used in welder trade

Electrode holder (Fig 1)

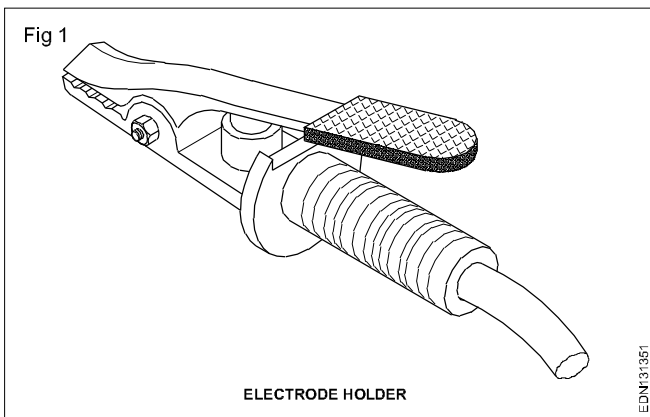

Earth clamp (Fig 2)

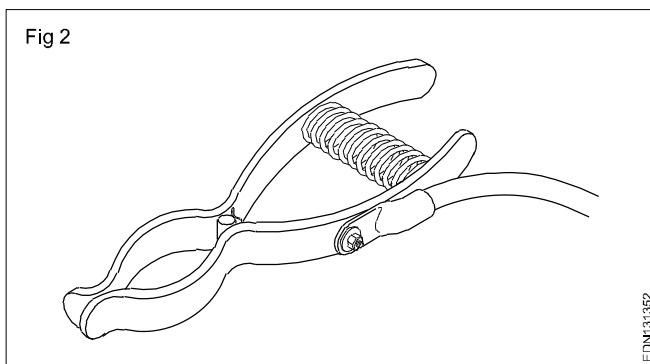

Work cable attachments (Fig 3)

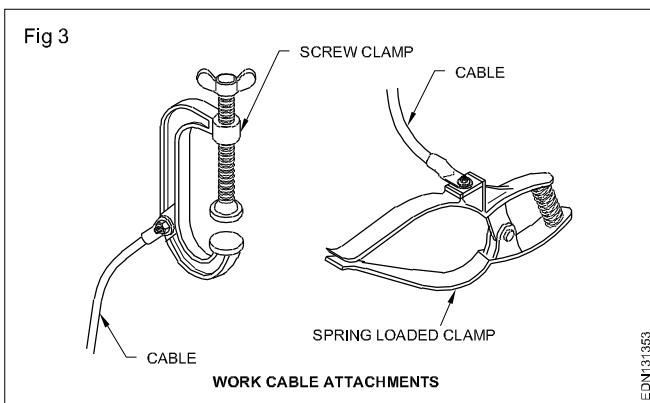

Goggles (Fig 4)

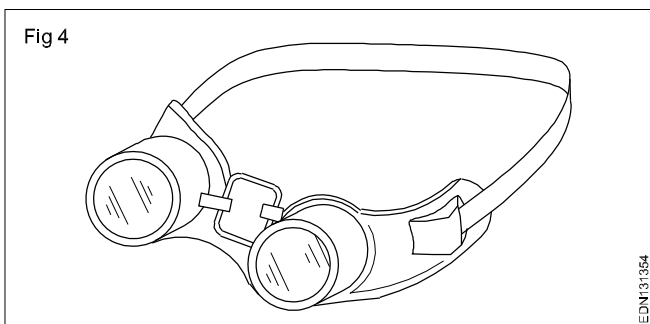

A.C welding transformer (Fig 5)

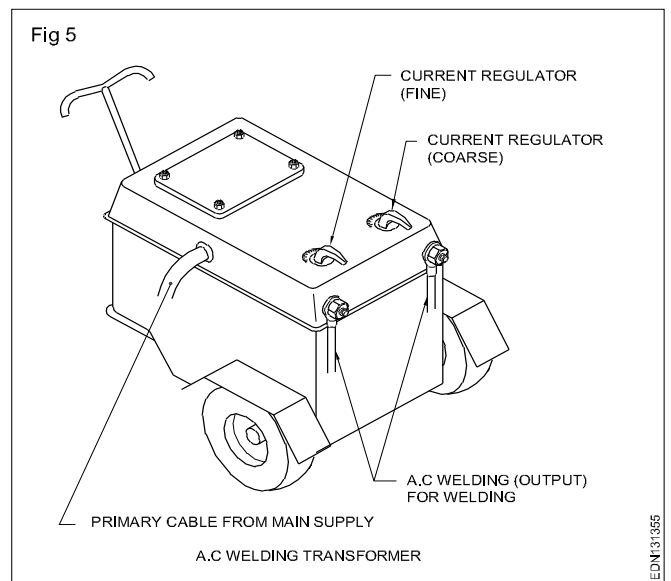

Cable attachments (Fig 6)

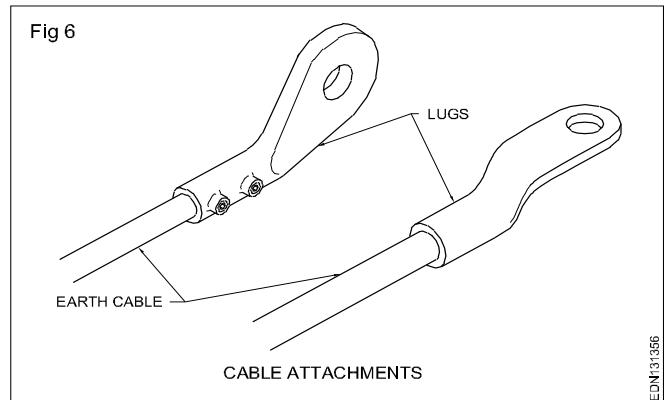

Cutting torch (Fig 7)

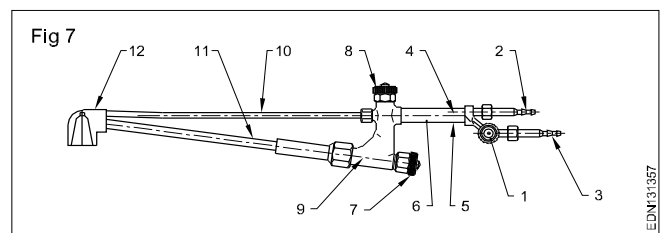

Regulator (Fig 8)

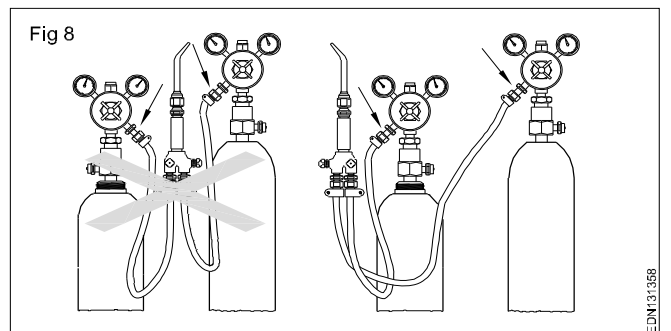

# Freehand drawing of hand tools and measuring tools used in carpenter trade

Collapsible carpenter rule (Fig 1)

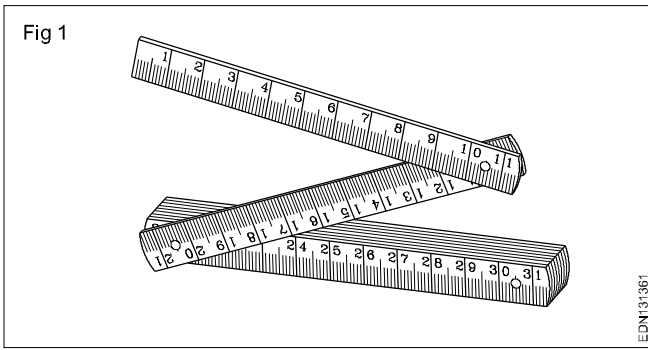

Try square (Fig 5)

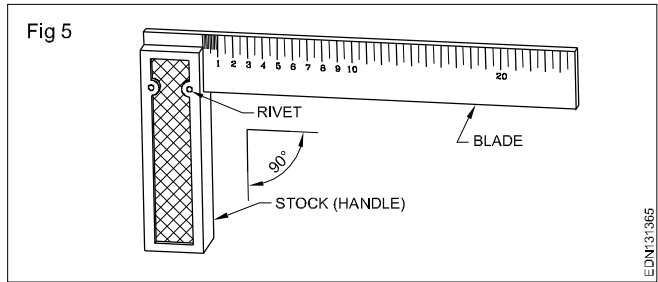

Folding rule (Fig 2)

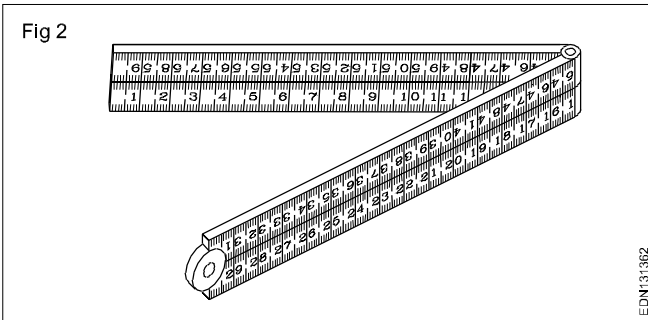

Plumb bob (Fig 6)

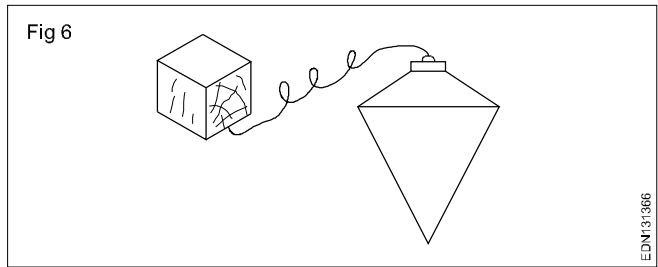

Tape Measure (Fig 3)

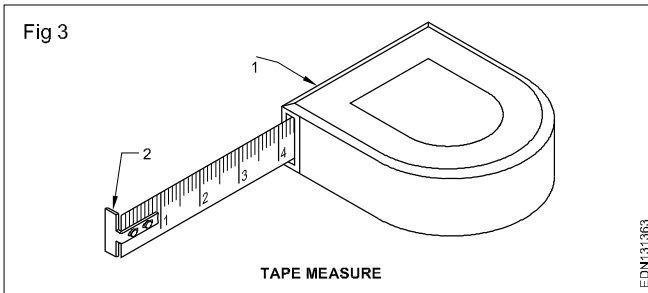

Crow bar (Fig 7)

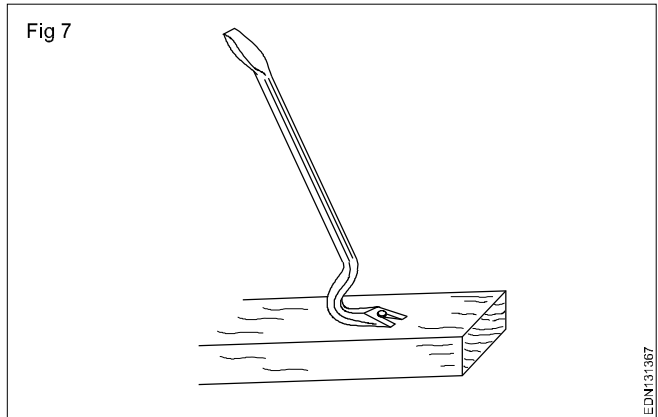

Carpenter's work bench (Fig 4)

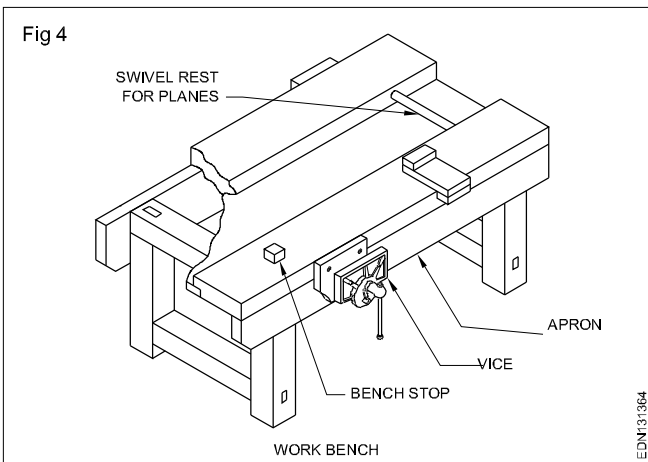

Marking knife or striking knife (Fig 8)

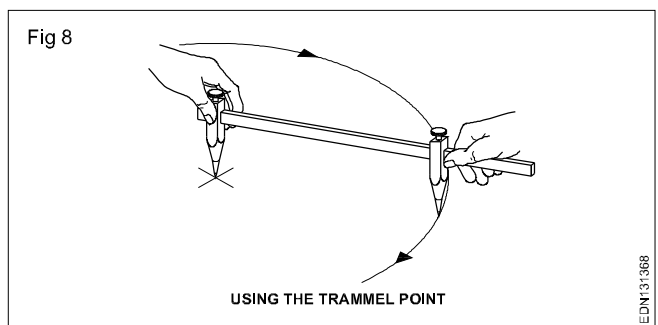

Marking knife (Fig 9)

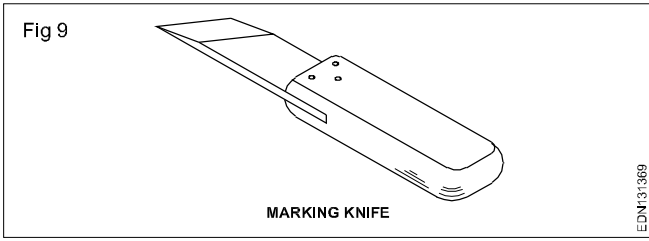

'T' - Bevels (or) bevel square (Fig 10)

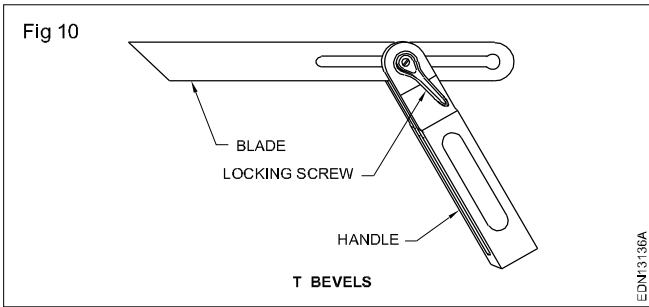

Standard wire gauge (Fig 11)

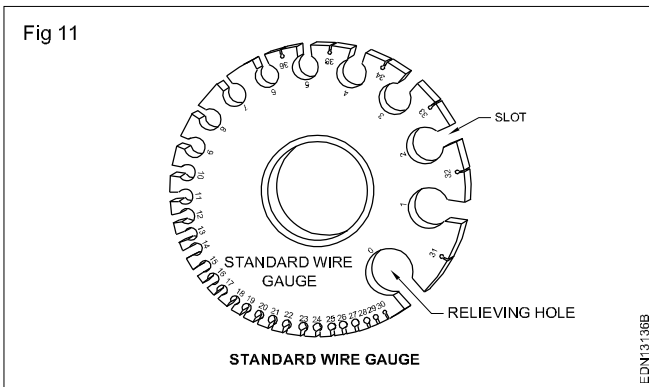

Panel gauge (Fig 12)

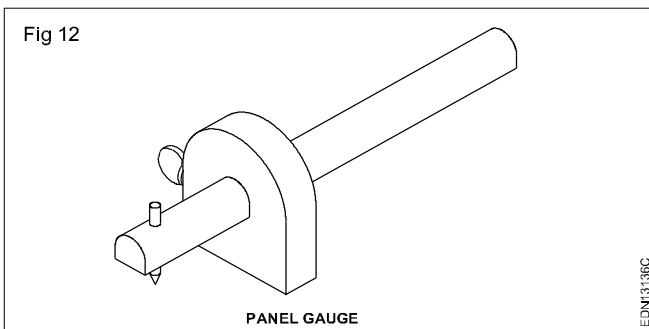

Cross cut saw (Fig 13)

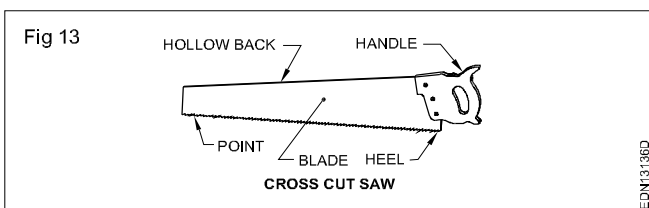

Coping saw (Fig 14)

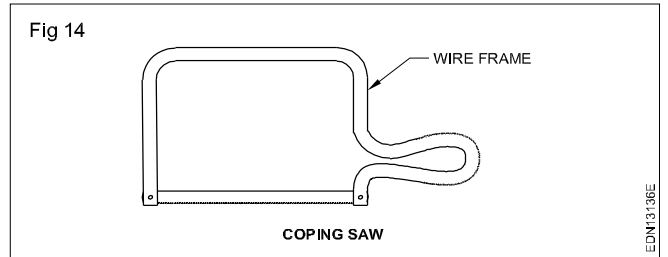

Fret saw (Fig 15)

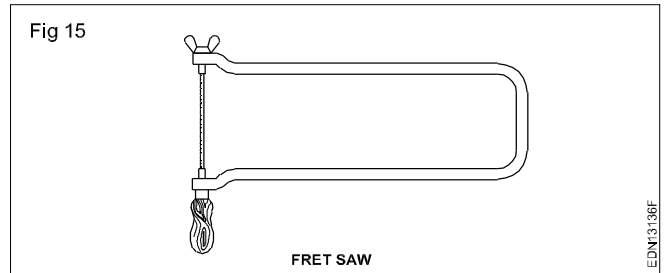

Compass saw (Fig 16)

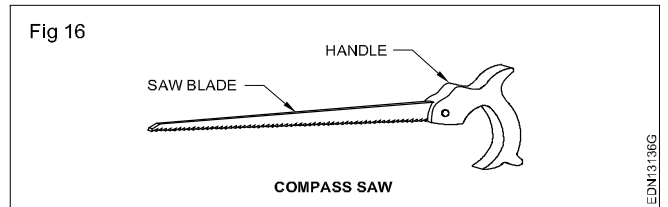

Bow saw (Fig 17)

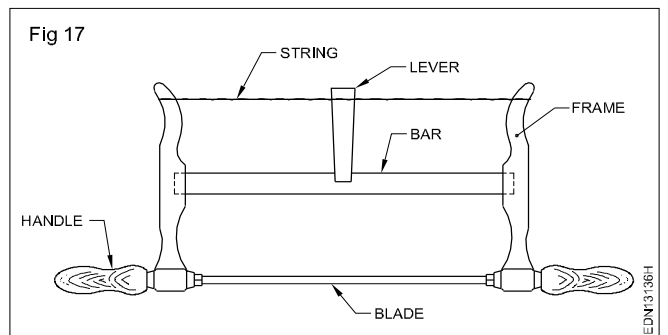

Steel scriber (Fig 18)

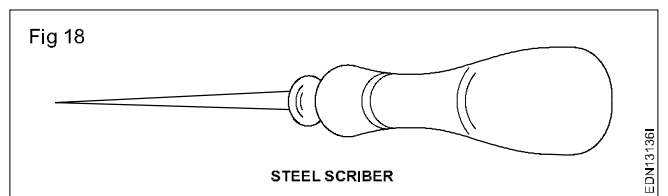

Butt gauge (Fig 19)

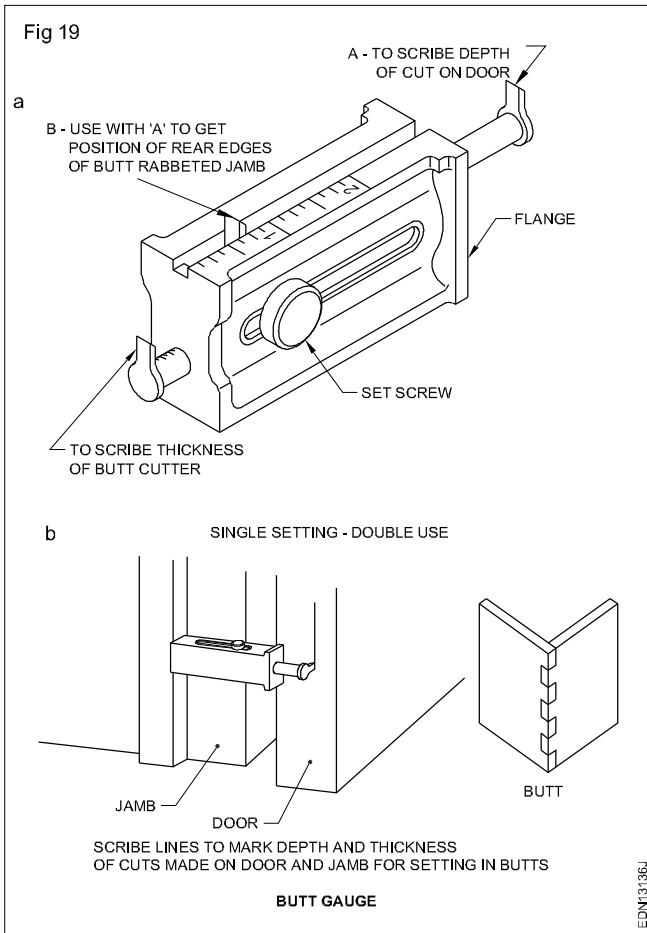

Pairs of pincers (Fig 20)

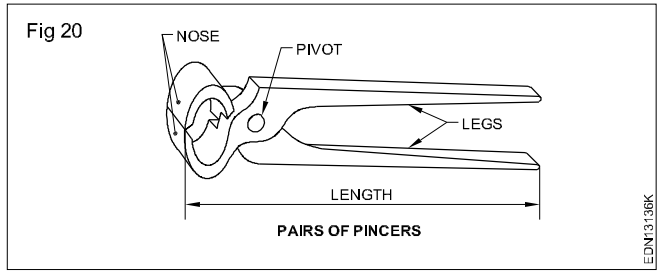

Marking gauge (Fig 21)

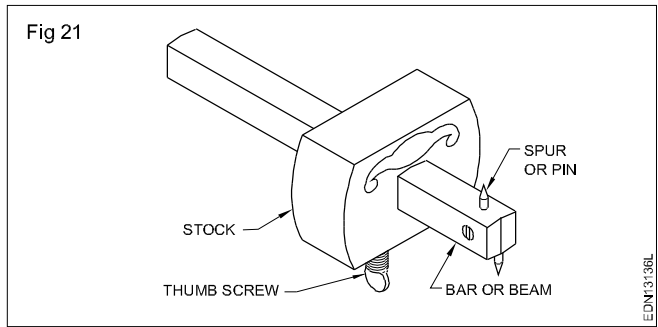

**Freehand drawing of hand tools and measuring tools used in foundryman trade**

Trowels (Fig 1)

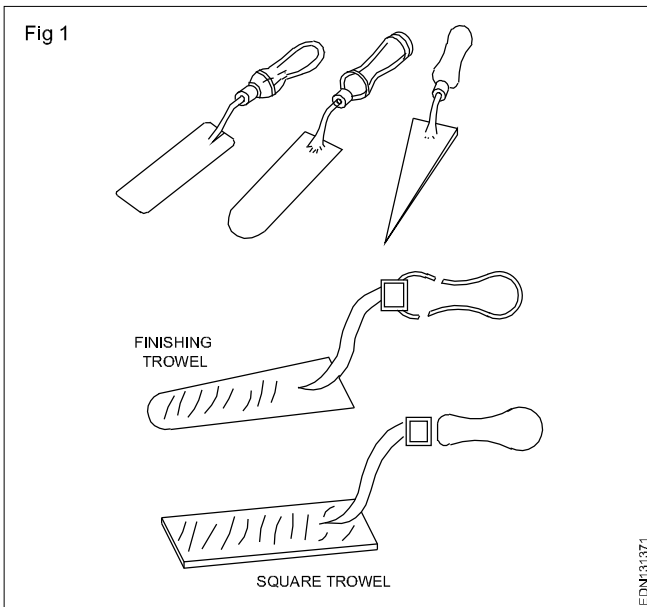

Cleaner or lifter (Fig 2)

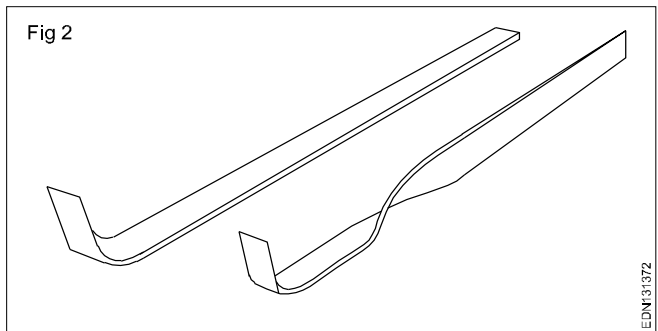

Rammers (Fig 3 & 4)

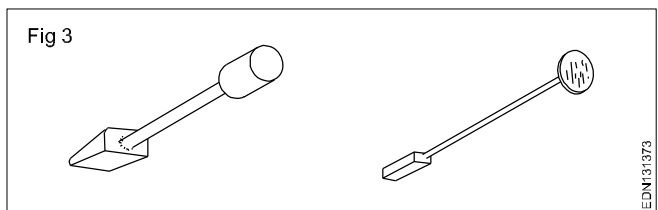

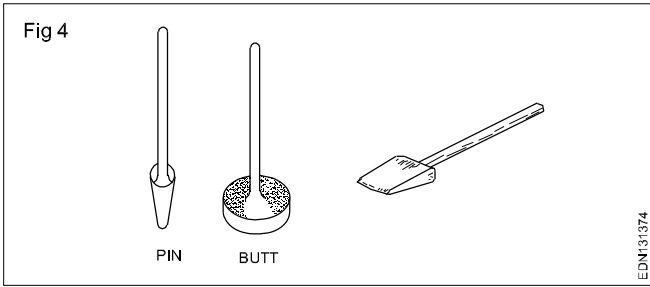

Vent wire (Fig 5)

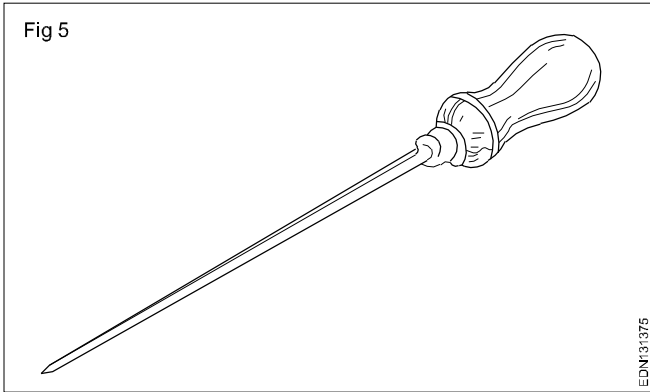

Draw spike (Fig 6 & 7)

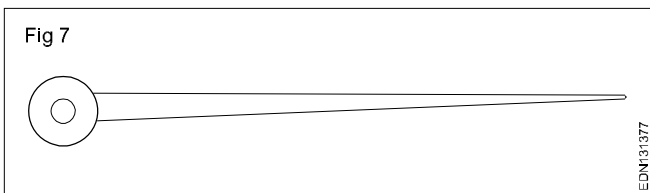
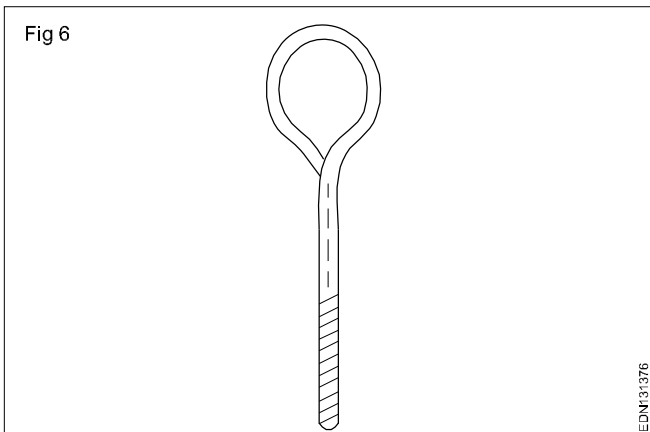

Leveler (Fig 8)

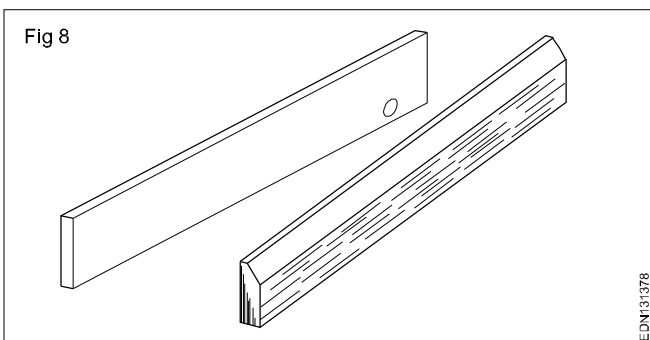

Spirit level (Fig 9)

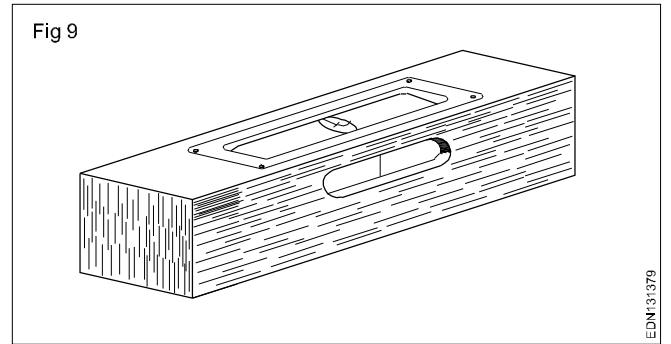

Hand bellow (Fig 10)

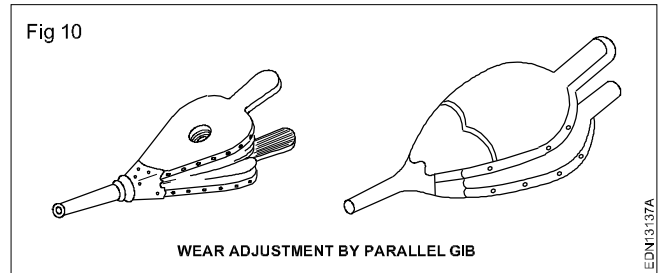

Foundry brush (Fig 11)

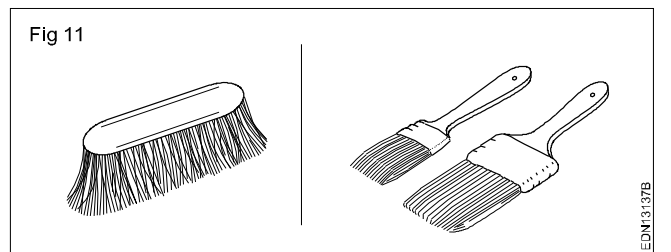

Mallets (Fig 12)

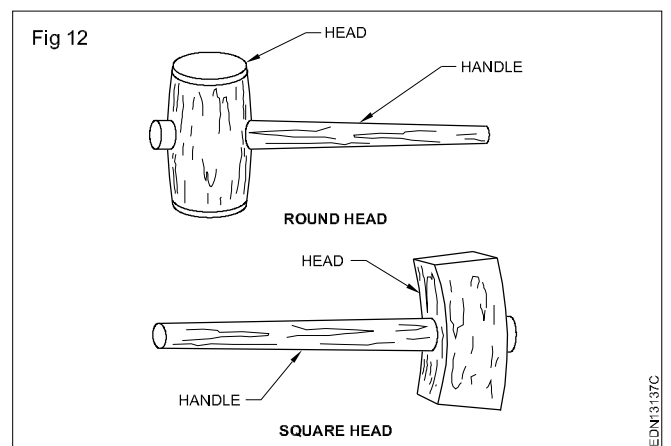

Swab (Fig 13)

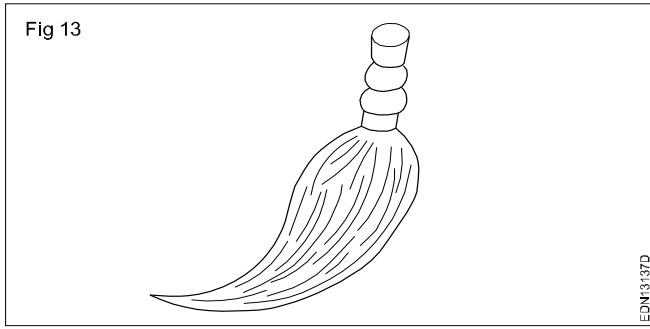

Riddle (Fig 16)

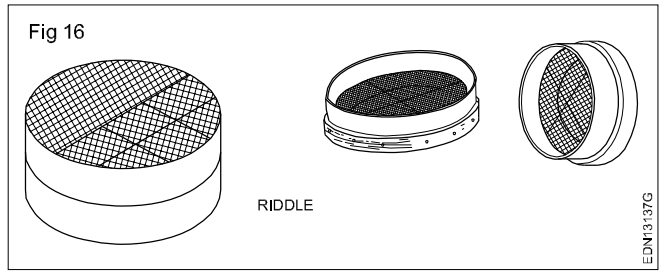

Hand shovel (Fig 14)

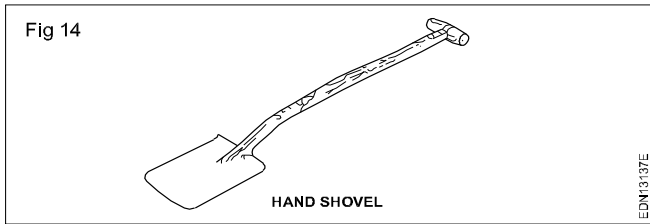

Water sprinkler (Fig 17)

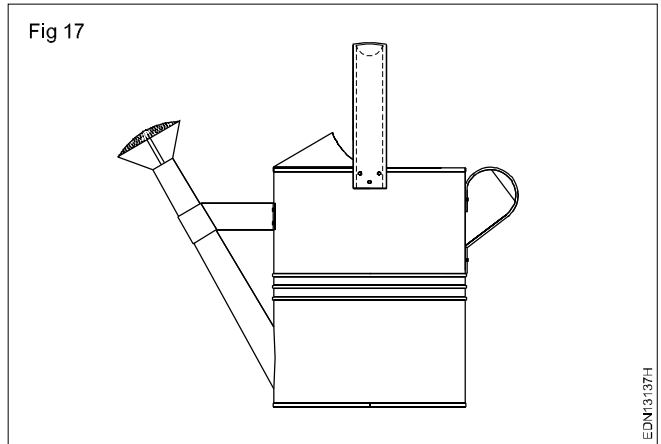

Runner and riser pins (Fig 15)

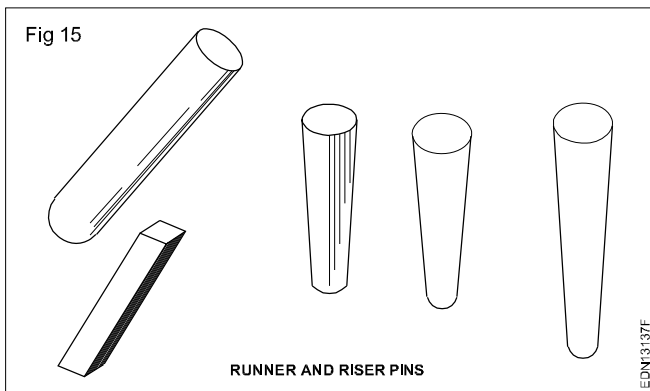

Smoother (Fig 18)

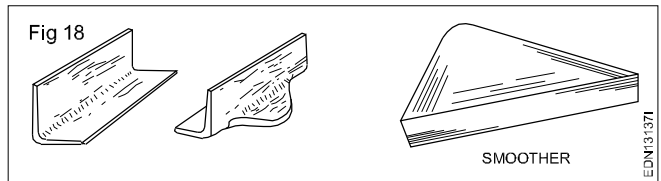

Freehand drawing of simple fasteners (bolts, nuts and rivets etc.) trade related sketches

Hexagonal headed bolt (Fig 1)

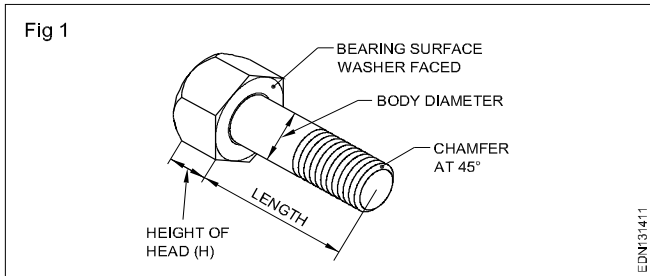

Square headed bolt (Fig 2)

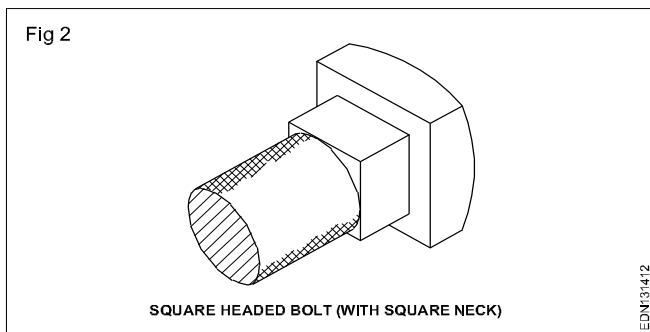

Hexagonal nuts (Fig 3 & 4)

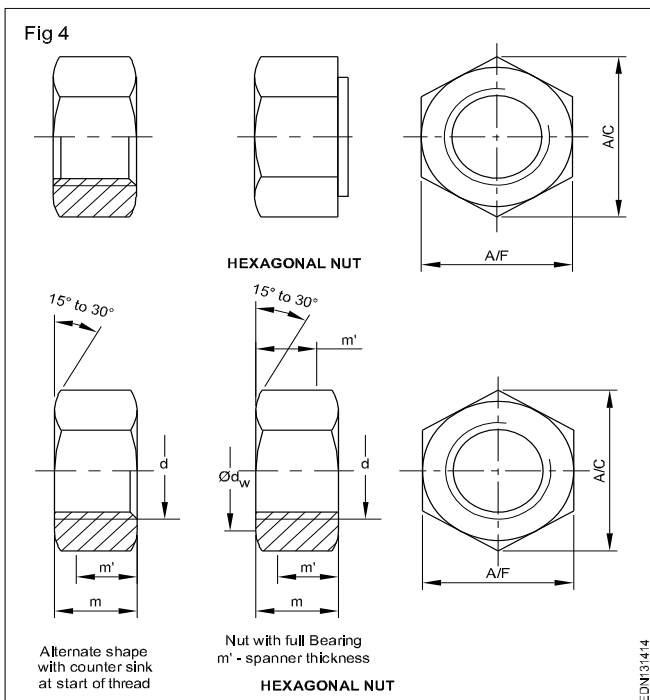
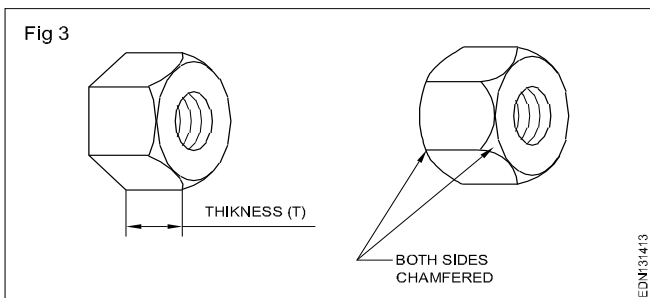

Square nuts (Fig 5)

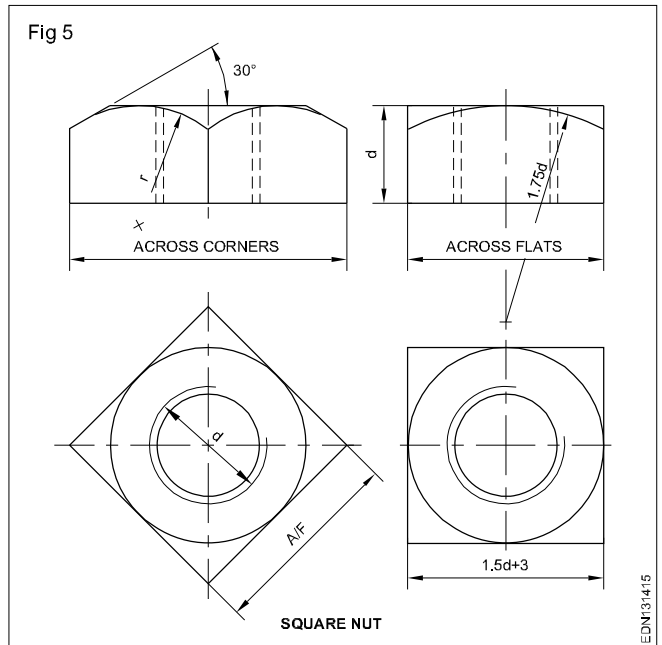

Dome nut and cap nut (Fig 6)

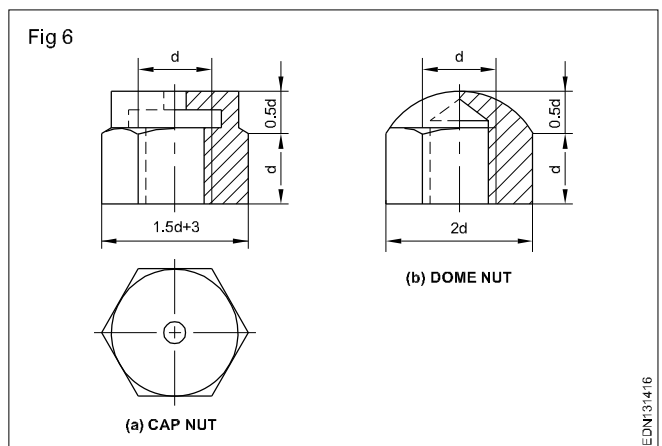

Collared nut (Fig 7)

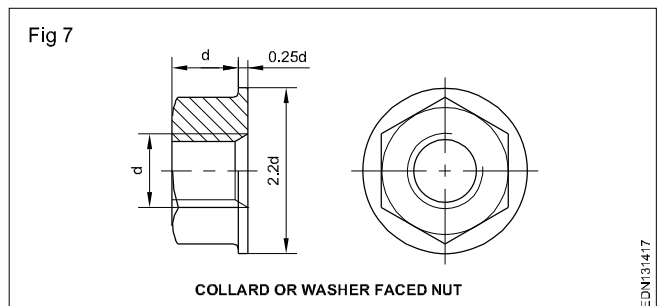

Types of rivets (Fig 8)

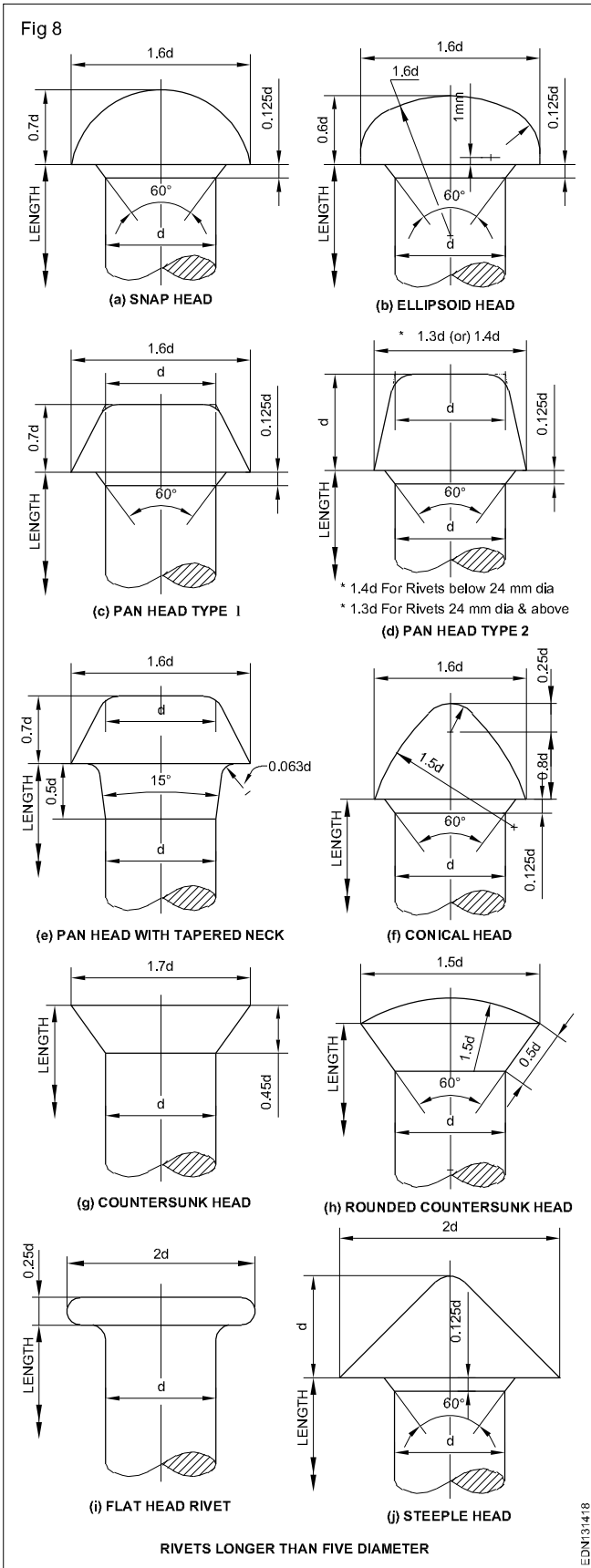











**Lines - Definition, types and applications in drawing as per BIS: 46-2003 and classification of lines**

Drawings are made up of different types of lines. Just as language with alphabets and grammar.

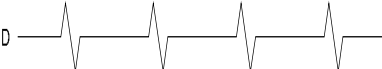
Lines of different thickness and features are used for specific use (Fig 1 and 2).

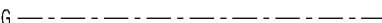
Technical drawings are drawn with different types of lines. By proper choice and application of lines product features can be correctly defined in a drawing. Different types of lines recommended for specific applications are given in Table 1.

Table 1  
**Types of lines and their application**

Lines	Description	General applications See figure and other relevant figure
Fig 1 A  0.5	Continuous thick	A1 Visible outlines A2 Visible edges
B  0.2	Continuous thin (straight)	B1 Imaginary lines of intersection B2 Dimension lines B3 projection lines or extension line B4 Leader lines B5 Hatching B6 Outlines of revolved sections in place B7 Short centre lines B8 Thread line B9 Diagonal line
C  0.2	Continuous thin free hand	C1 Limits of partial or interrupted views & sections, if the limit is not a chain thin
D  0.2	Continuous thin (Straight) with zig-zags	D1 Line (See figures)
E  0.3	Dashed thick	E1 Hidden outlines E2 Hidden edges
F  0.2	Dashed thin	F1 Hidden outlines F2 Hidden edges
G  0.2	Chain thin	G1 Centre lines G2 Lines of symmetry G3 Trajectories
H  0.3	Chain thin, thick at ends & changes of direction	H1 Cutting planes
J  0.5	Chain thick	J1 Indication of lines or surfaces to which a special requirement applies
K  0.2	Chain thin double-dashed	K1 Outlines of adjacent parts K2 Alternative and extreme positions of movable parts K3 Centroidal lines K4 Initial outlines prior to forming K5 Parts situated in front of the cutting plane

- 1 This type of line is suited for production of drawings by machines.
- 2 Although two alternatives are available, it is recommended that on any one drawing, only one type of line be used.

Thickness of the line should be chosen according to the size and type of the drawing from the following range. (IS:10714-1983) 0.18, 0.25, 0.35, 0.5, 0.7, 1, 1.4 & 2 mm.

In the above range, for craftsman 0.5 is preferred. The Table 2 shows the 0.5 line range and other lines under this range. The numbers in right side of the lines refers the line thickness in mm.

Table 2

Fig 2

A		0.5
B		0.2
C		0.2
D		0.2
E		0.3
F		0.2
G		0.2
H		0.3
J		0.5
K		0.2

EDN141512

All the views of a component drawn to one particular scale should have the same range of line thickness.

**Types of lines:** Ten types of lines are used in general engineering drawing as per IS:10714-1983. Out of which first four types of lines are continuous lines of both thick and thin. (Type A to D)

Continuous thick line (A type) is used for drawing visible outlines (A1) and visible edges (A2). (Fig 3) These lines are also called as object lines.

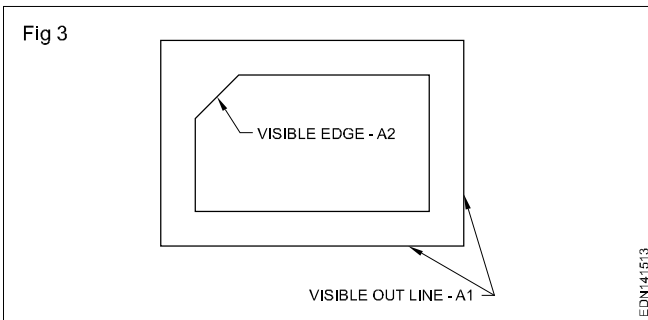

**Continuous thin lines (B type):** Continuous thin lines are used for many applications as stated in Table 1. A few applications of B types of lines are shown in Fig 4.

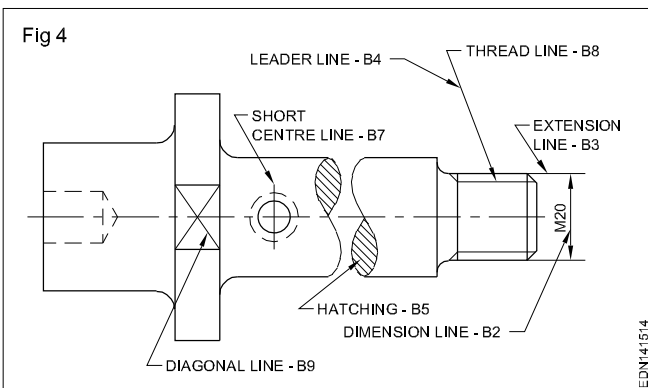

**A leader line - B4 (Fig 4):** A leader line is a line referring to a feature (dimension, object, outline etc). A leader line should terminate

- with a dot
- with an arrow head

- without a dot or arrow head (Fig 5)

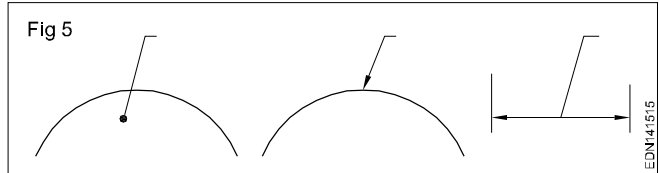

**Hatching lines (B5):** Hatching lines are the lines inclined parallel lines. The minimum space between these lines should be more than twice the thickness of the heaviest line in the drawing. It is recommended that these spacings should never be less than 0.7 mm. (Fig 4)

For showing the limits of partial or interrupted views and sections continuous thin free hand lines (C1) or continuous thin straight lines with zig-zag (D1) are used. (Fig 6)

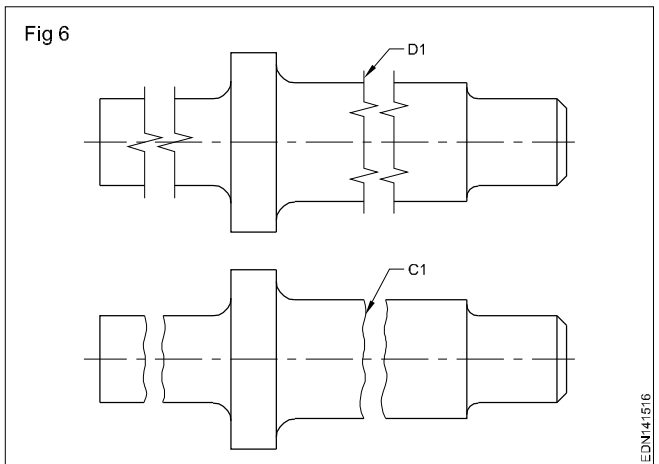

Lines of type E to K in Table 1 are of the non-continuous type. Some of these thin and some are thick. For hidden lines both thick and thin dashes (E & F type) are available, it is recommended that on any one drawing, only one type of (Thick or thin) line be used. (Fig 7)

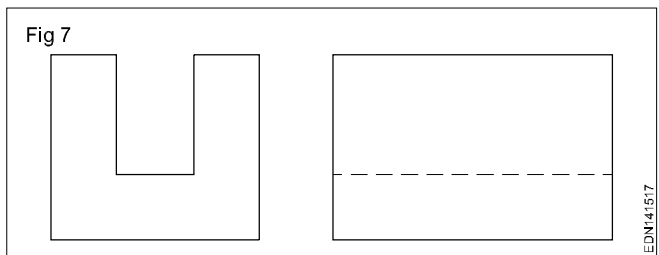

**Chain lines (Thin):** Chain lines are used for drawing centre lines of circles, cylinders etc. Same lines are also used to show the axis of symmetry in symmetrical objects. To save time and space a partial of a whole component is drawn. The line of symmetry is identified at its ends by two thin short parallel lines drawn at right angle to it. (Fig 8)

Another method of representing symmetrical shape is to extend the object lines beyond the axis of the symmetry. (Fig 9) In this case the short parallel lines described above is omitted. The same lines are also used to show the repetitions of features of a component. (Fig 10)

For drawing a sectional view, plane of cutting is to be shown in other view. Cutting plane (H1) in Table 1 is drawn with thin chain, thick at ends and also at the places of direction change. (Figs 11 & 12)

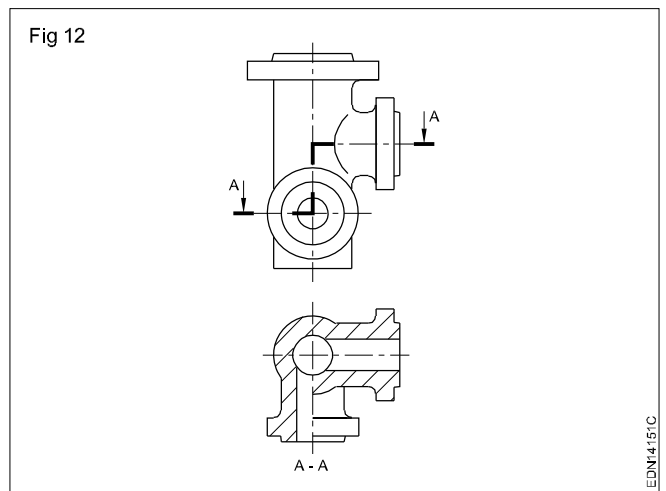
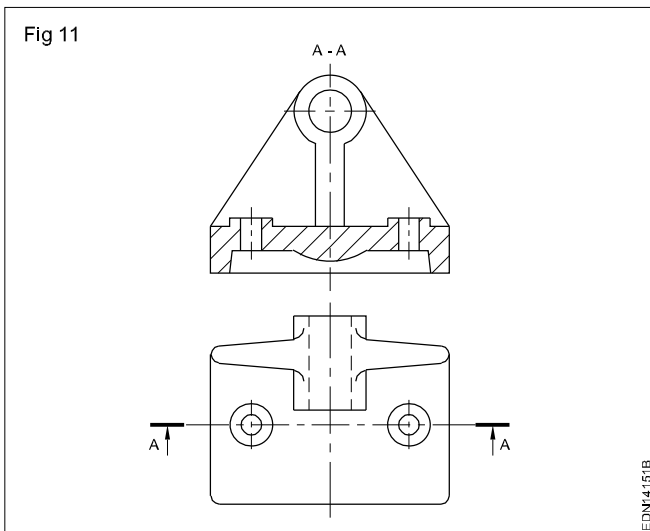
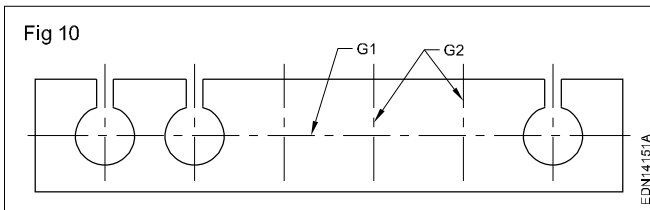
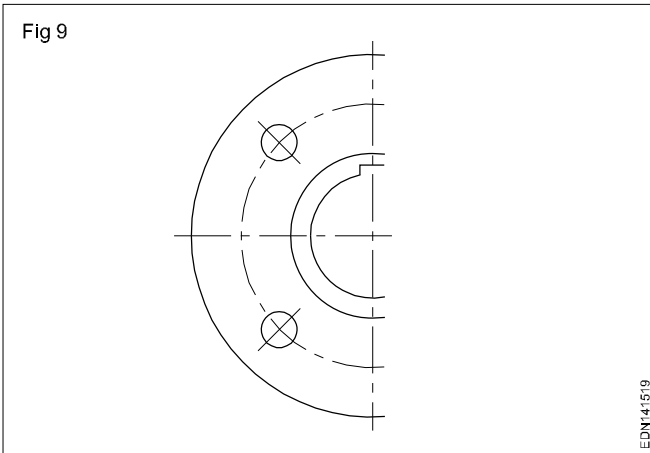
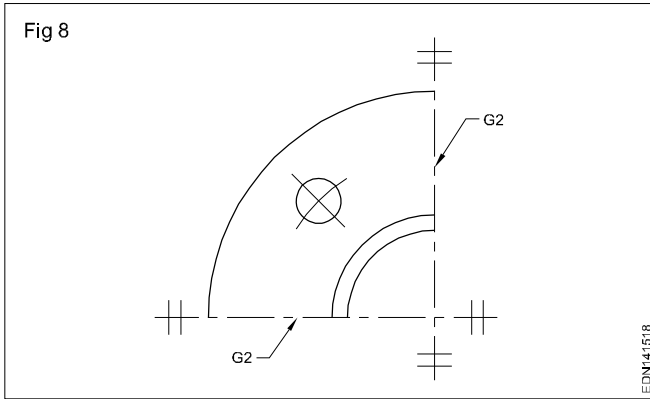

If thick chain lines (J1) in table 1 are drawn on a surface, it indicates some special treatment/application on that surface. (Fig 13)

Chain thin double dashed (K) lines are applied for the following:

- K1 - Outlines of adjacent parts (Fig 13)
- K2 - Alternative and extreme positions of moving parts. (Fig 13)

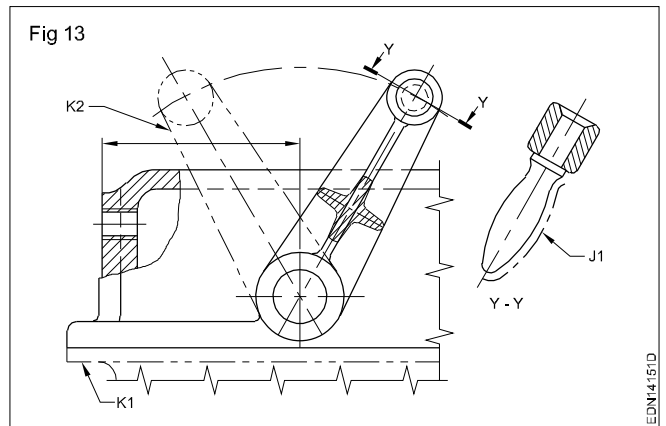

- K3 - Centroidal lines (Fig 14)

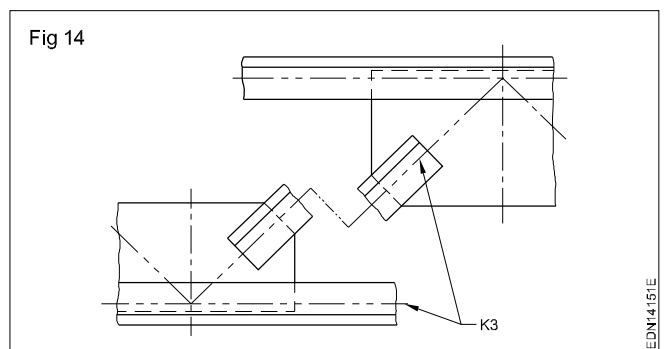

K4 - Initial outlines prior to forming (Fig 13)

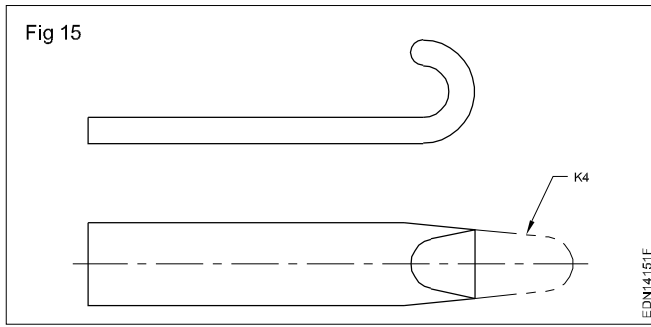

K5 - Parts situated in front of the cutting plane (Fig14)

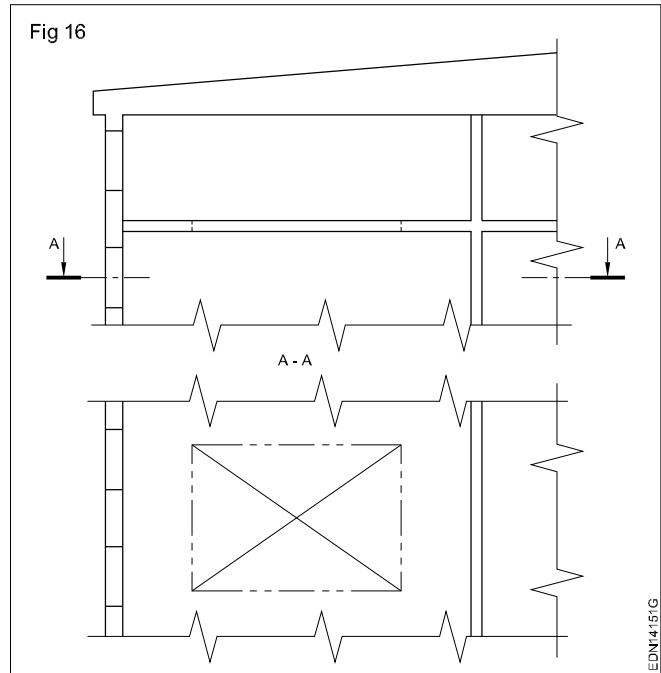

**Lines - Drawing lines of given length (straight, curved), drawing of parallel lines, perpendicular line and methods of division of line segment**

There are a lot of ways to define straight and curved lines; the most elaborate way to define them is the following:

- A straight line is a succession of points that are aligned in the same direction. Or in other words, in order to go from one point to another, we never change direction.

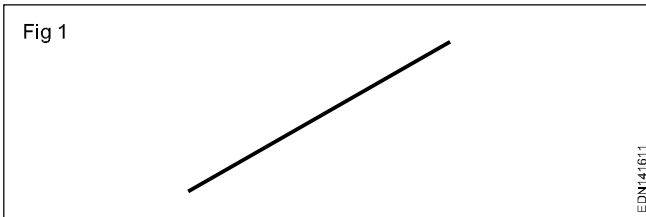

- On the contrary, the points of a curved line do change direction from one point to the next.

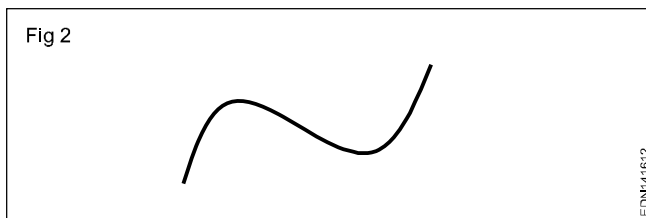

- If there aren't any obstacles, there are plenty of ways to do this...for example:

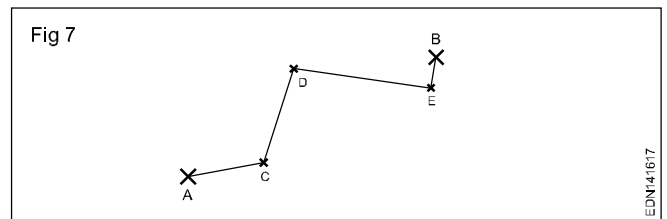
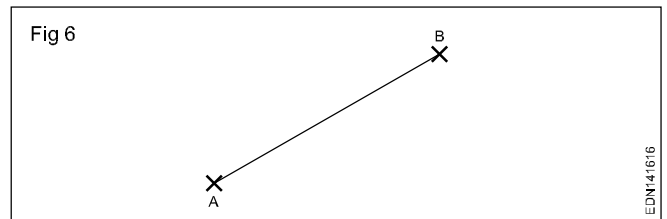
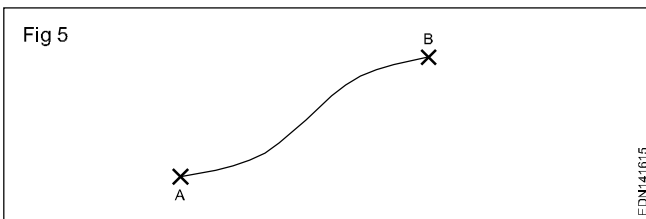
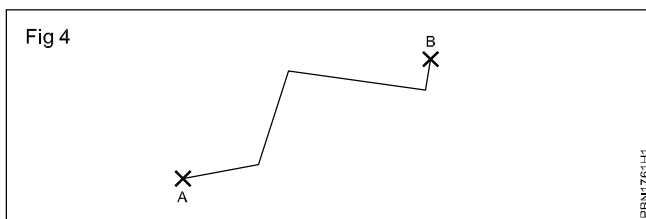
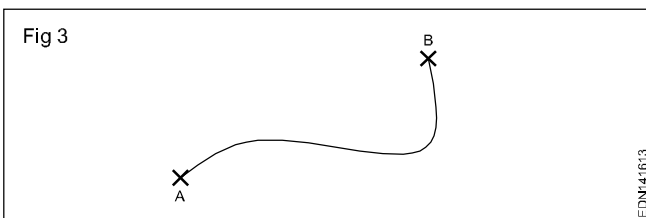

**Tangent line**

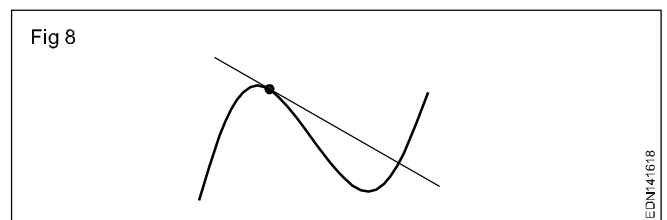

**4 Easy ways to draw curved line**

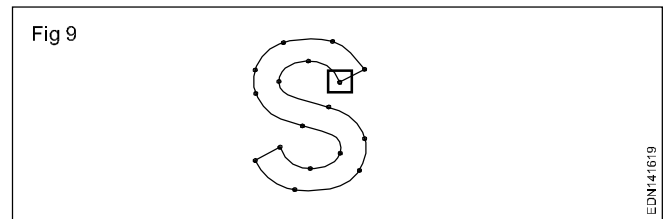

**Drawing curved dashed line**

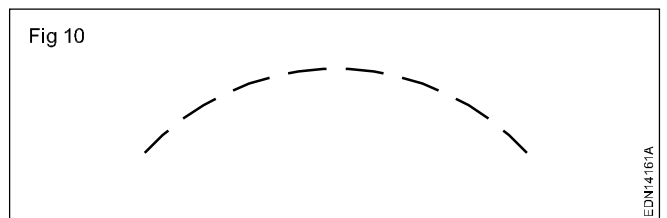

**To join two lines, that are at right angles, with a given radius**

The accompanying figures show four steps for how to draw a right angled joint.

- Draw a right angle and arcs that represents the desired radius. (Fig 11a)

EDN141616

EDN141617

EDN141618

EDN141619

EDN14161A

- Draw tangential lines on these arcs. (Fig 11b)
- Join CP with BP and EP with perpendicular lines. (Fig11c)

- Place the compass point on CP and draw the radius which starts at BP and ends at EP. (Fig 11c)
- Join the radius with straight lines. (Fig 11d)

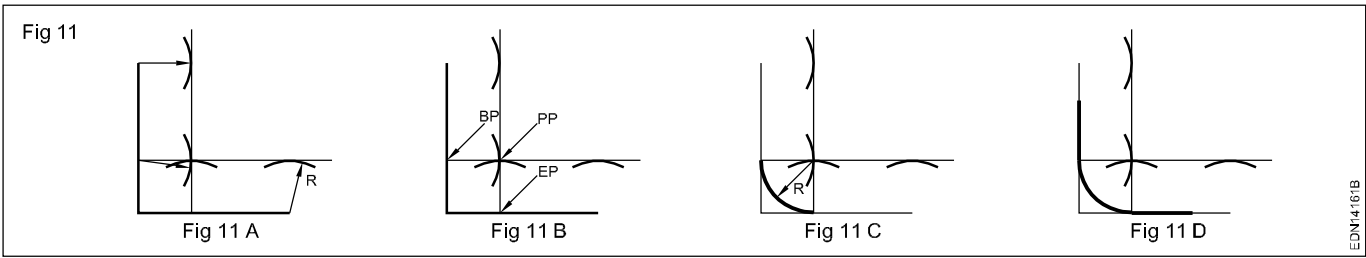

The accompanying figures show four steps of how to draw an acute joint.

- Draw an acute angle with arcs that represents the desired radius. (Fig 12a)
- Draw tangential lines on these arcs. (Fig 12b)

- Join CP with BP and EP with perpendicular lines. (Fig12c)
- Place the compass point on CP and draw the radius which starts at BP and ends at EP. (Fig 12c)
- Join the radius with straight lines. (Fig 12d)

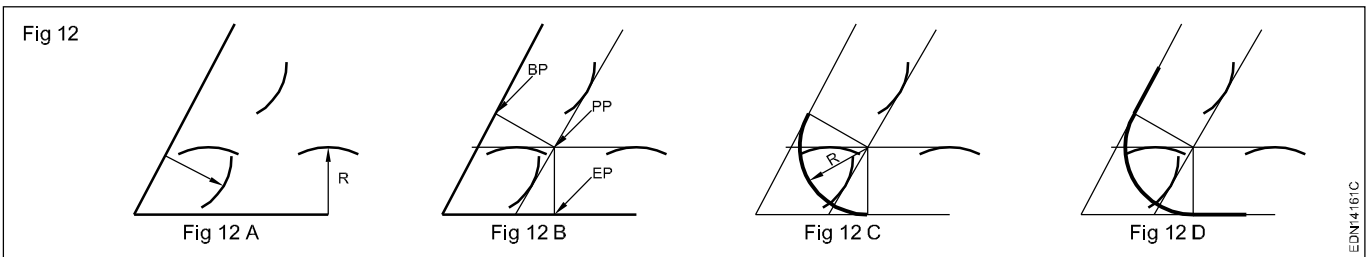

Follow the procedure and draw the exercise in the A3/A4 sheet.

**Procedure**

**1 Draw six horizontal parallel lines of 50 mm long with 10 mm intervals (Fig 1).**



- Draw a vertical line AB 50 mm long, using setsquare on left side.
- Mark points on the vertical line AB with 10 mm intervals.
- Butt a setsquare on the line AB.
- Using another setsquare, draw parallel lines through the points marked.

**Use sharpened conical point pencil.**  
**Keep the pencil slightly inclined towards the direction of the movement.**  
**While drawing rotate the pencil to keep the constant thickness.**  
**Maintain uniform pressure on the lead of the pencil.**

**2 Draw six vertical parallel lines of 50 mm length with 10 mm intervals (Fig 2).**

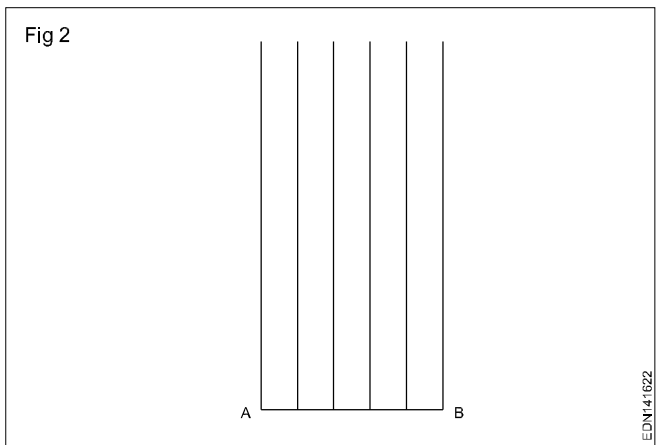

- Draw a horizontal line AB 50 mm long.
- Mark the points with 10 mm intervals.
- Butt a setsquare on the line AB.
- Using another setsquare draw vertical parallel lines from left to right.

**Draw the vertical lines from bottom to top.**

**3 Draw 45° inclined lines (Fig 3).**

- Draw a horizontal line AB 60 mm long.
- Butt a setsquare on the line AB, draw vertical lines from the points A and B using another setsquare.
- Set off AD and BC equals to 40 mm and complete the box.

Fig 3

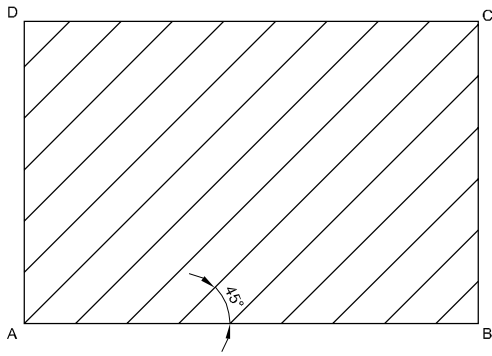

EDN141623

- On lines AB and DC mark 10 mm points.
- Butting the 60° setsquare on the line AB, using 45° setsquare draw inclined parallel lines through the marked points.

**Draw lines from bottom to top.**

- 2 Draw the following exercises on A4 sheets (Fig 4).

Fig 4

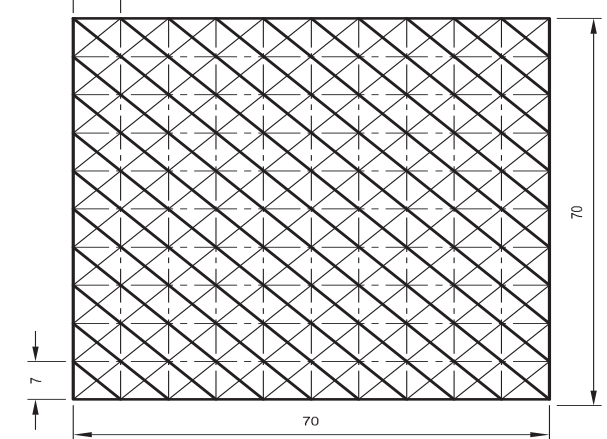
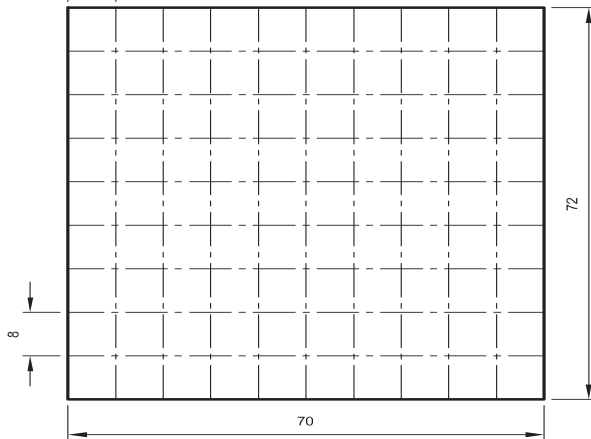
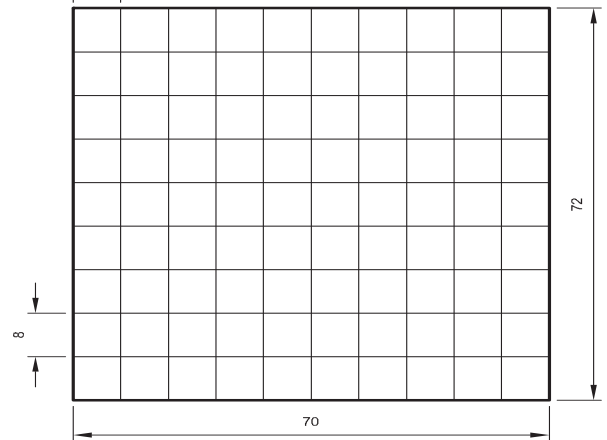
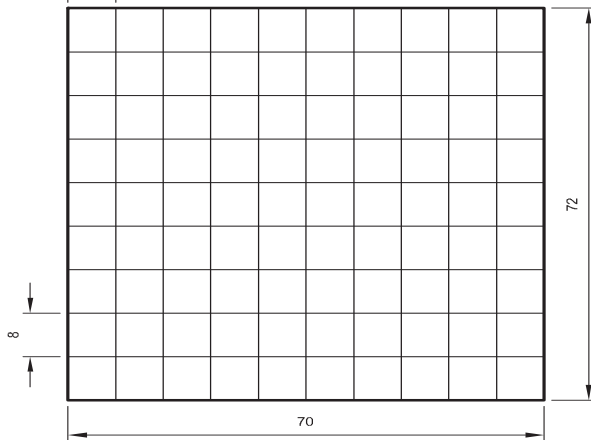
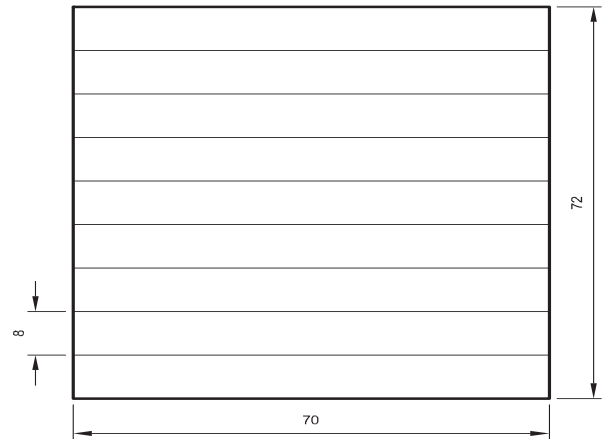
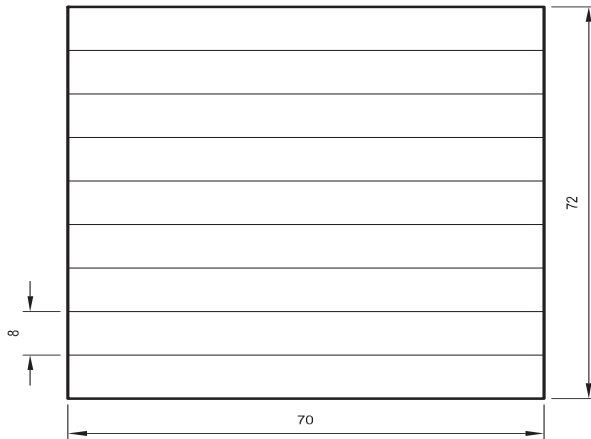

EDN141624

## Division of a line segment

Before knowing about the division of a Line segment, let us know what a line and line segment means,

### Line and line segment

A line is a collection of points along a straight path which extends to both the directions without endpoints. (Fig 5)



AB is a line which doesn't have any ending. (Fig 6)

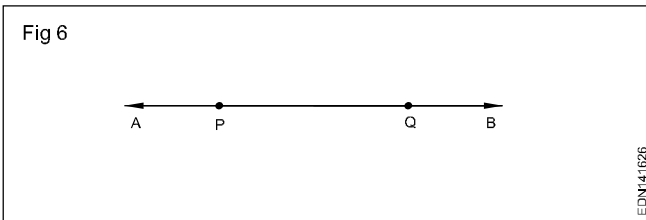

A line segment is a part of a line between two endpoints.

PQ is a line segment having P and Q as end points on the line AB.

### Division of a line segment

A line segment can be divided into 'n' equal parts, where 'n' is any natural number.

For example; a line segment of length 10 cm is divided into two equal parts by using a ruler as,

- Mark a point 5 cm away from one end.
- 10 cm is divided into two 5 cm line segments.

Similarly, a line segment of length 15 cm can be divided in the ratio 2:1 as,

- AB is the line segment of length 15 cm and C divides the line in the ratio 2:1.

- Let  $CB = x$ , then  $AC = 2x$
- $AC + CB = 2x + x = 15$ ,  $x = 5$
- $AC = 10$  cm and  $CB = 5$  cm.
- Mark point C, 10 cm away from A

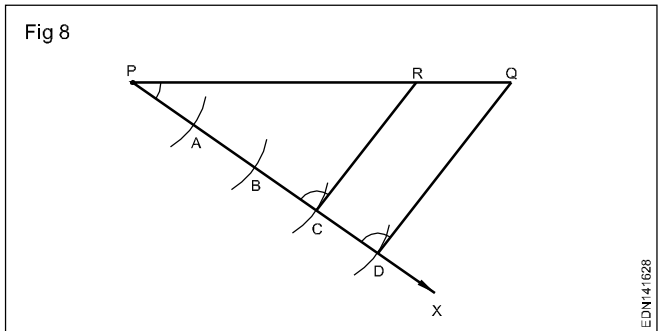
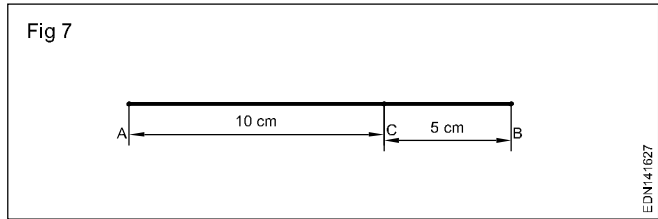

## Method of division of line segments

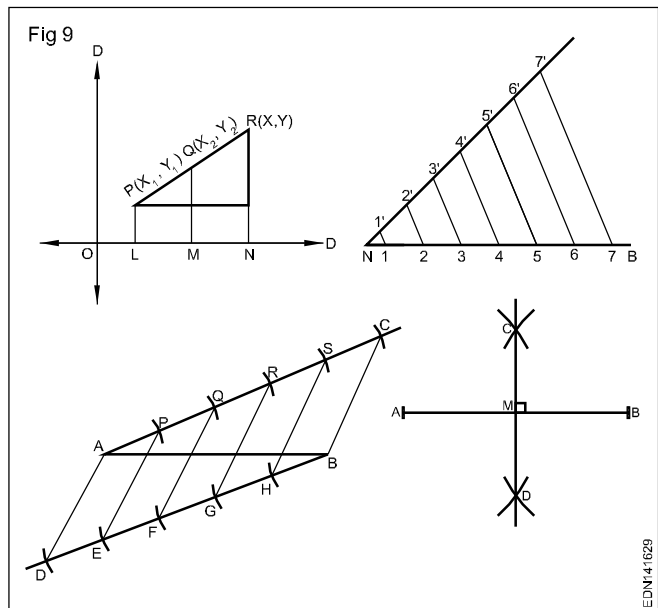



**Drawing of geometrical figures - Definition, nomenclature and practice of angle - Measurement and its types, and types of angle and triangle**

**Angles:** Angle is the inclination between two straight lines meeting at a point or meet when extended. AB and BC are two straight lines meeting at B. The inclination between them is called an angle. The angle is expressed in degrees or radians.

**Concept of a degree:** When the circumference of a circle is divided into 360 equal parts and radial lines are drawn through these points, the inclination between the two adjacent radial lines is defined as one degree. Thus a circle is said to contain 360°. (Fig 1)

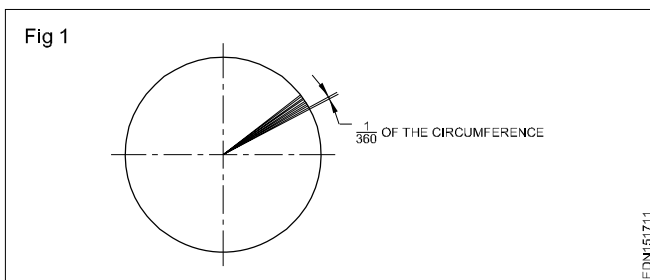

**Acute angle:** If an angle which is less than 90° is called an acute angle. (Fig 2)

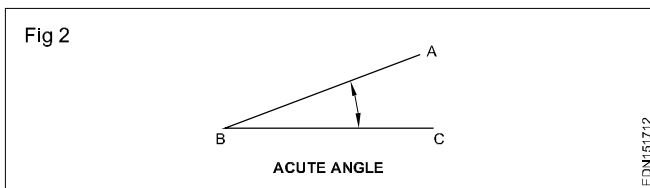

**Right angle:** Angle between a reference line and a perpendicular line is called right angle. (Fig 3)

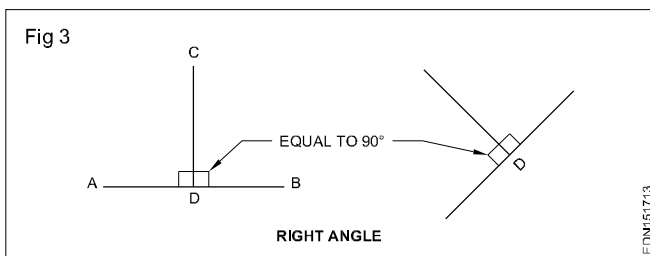

**Obtuse angle:** This refers to an angle between 90° and 180°. (Fig 4)

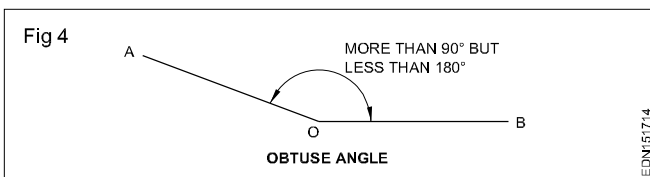

**Straight angle:** This refers to an angle of 180°. This is also called as the angle of a straight line. (Fig 5)

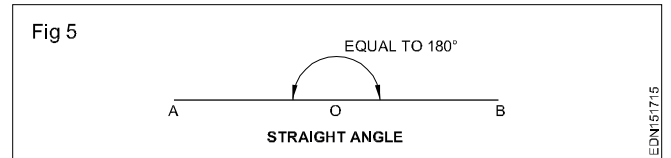

**Reflex angle:** It is the angle which is more than 180°. (Fig 6)

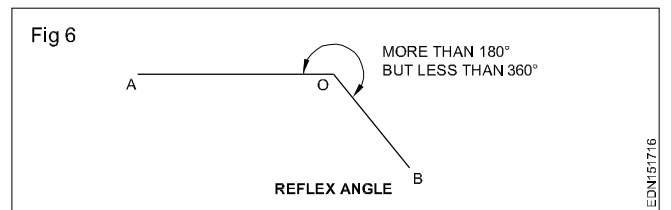

**Adjacent angles:** These are the angles lying on either side of a line. (Fig 7)

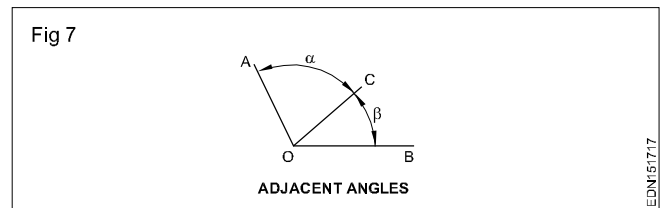

**Complementary angles:** When the sum of the two angles is equal to 90°, angle POQ + angle QOR = 90° angle POQ and angle QOR are complementary angles to each other. (Fig 8)

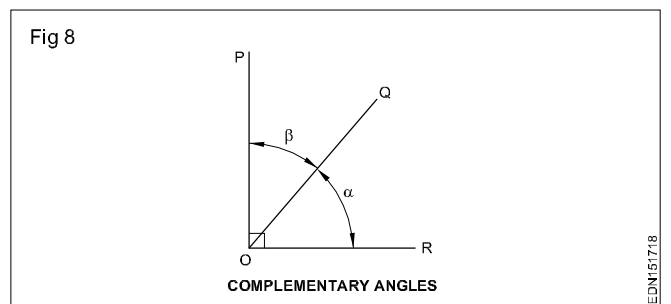

**Supplementary angle:** When the sum of the two adjacent angles is equal to 180°, example angle SOT + angle TOY = 180°, angle SOT and angle TOY are supplementary angles to each other. (Fig 9)

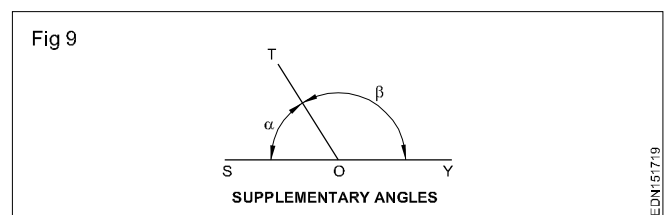

# Triangle - different types

Triangle is a closed plane figure having three sides and three angles. The sum of the three angles always equals to  $180^\circ$ .

To define a triangle, we need to have a minimum of three measurements as follows:

- 3 sides or
- 2 sides and one angle or
- 2 angles and one side

## Types of triangles

**1 Equilateral triangle** is a triangle having all the three sides equal. Also all the three angles are equal ( $60^\circ$ ) (Fig 1)

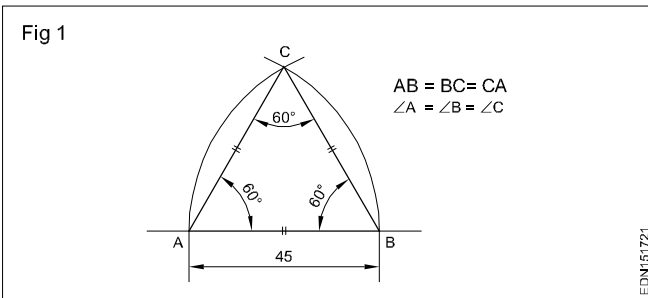

**2 Isosceles triangle** has two of its sides equal. The angles opposite to the two equal sides are also equal. (Fig 2)

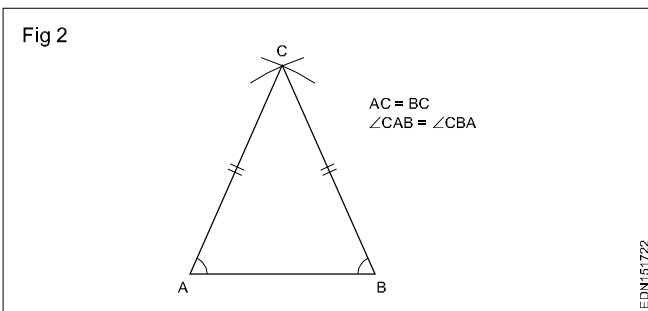

**3 Scalene triangle** has all the three sides unequal in lengths. All the three angles are also unequal. (Fig 3)

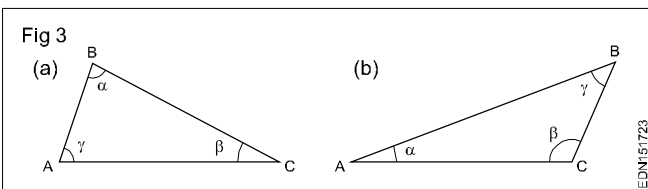

**4 Right angled triangle** is one in which one of the angles is equal to  $90^\circ$  (Right angle). The side opposite to right angle is called hypotenuse. (Fig 4)

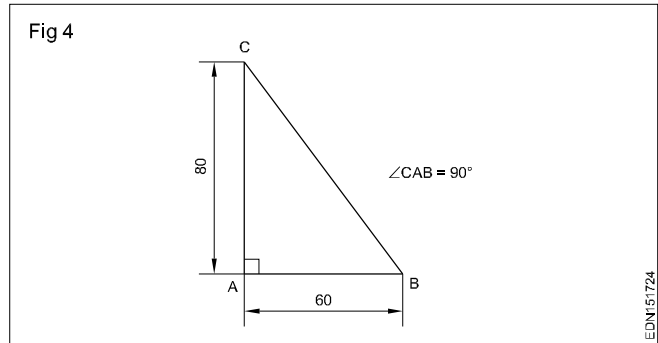

**5 Acute angled triangle** is one in which all the three angles are less than  $90^\circ$ . (Fig 5)

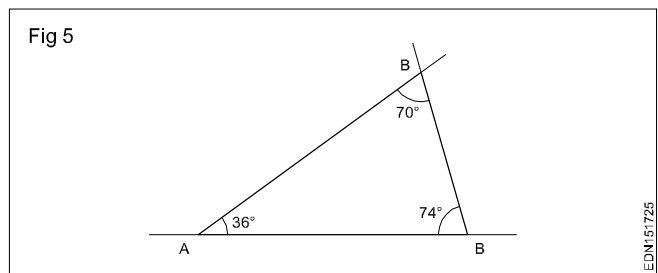

**6 Obtuse angled triangle** has one of the angles more than  $90^\circ$ . (Fig 6)

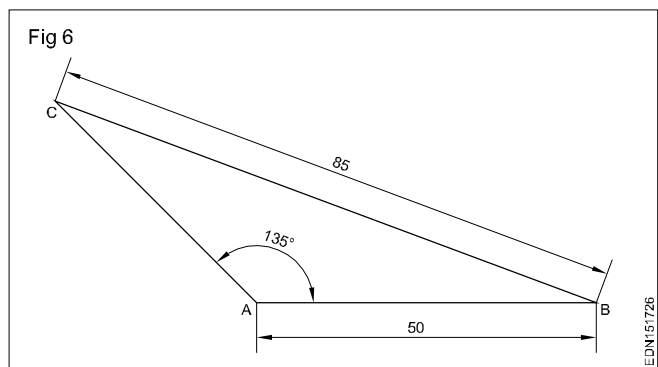

**The sum of the three angles in any triangle is equal to  $180^\circ$ .**

**The sum of any two sides is more than the third side.**

**Drawing of geometrical figures - Method of bisecting practice of angles and triangles**

**Procedure**

**1 Bisect a given straight line (Fig 1).**

- Draw a line AB of 70 mm long.
- With A and B as centres, more than half of AB as radius describe arcs on either side of the line AB.
- Let the arcs intersect at C & D.
- Join CD, bisecting the line AB at O.
- CD is the bisector of the line AB and  $AO = OB$ .

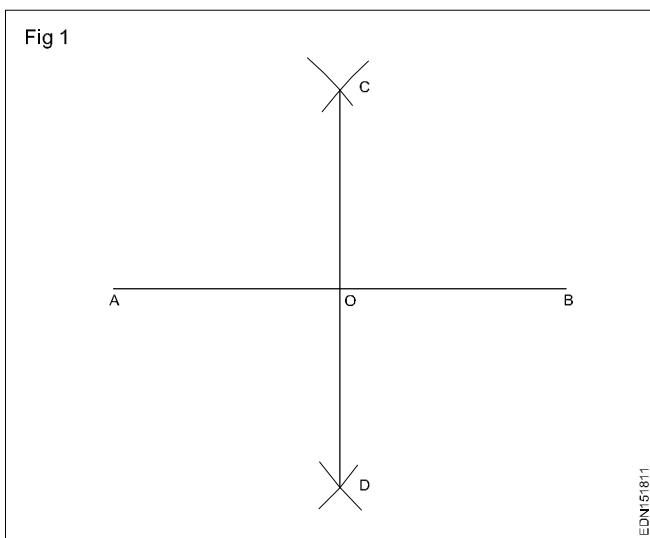

**2 Draw a perpendicular to a given straight line, from a given point in it (Fig 2).**

- 'C' is the point on the line AB.
- 'C' as centre draw arcs on the line AB at 1 & 2.
- 1 and 2 are centres draw arcs. The arcs intersect at D.
- Join DC.
- CD is the perpendicular line from the point 'C'.

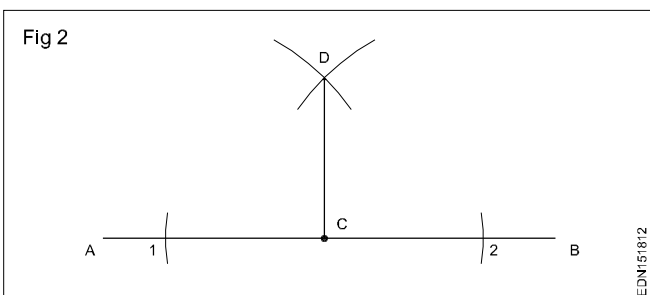

**3 Draw a perpendicular to a given straight line when the point is at the end of the line (Fig 3)**

- Draw a line AB (say 75 mm).
- 'A' as centre to a convenient radius draw an arc to meet AB at E.

- 'E' as centre AE as radius draw an arc to cut the previous arc at 'C'.
- 'C' as centre and with the same radius draw another arc to cut at 'D'.
- C and D as centre with the same radius draw arcs on top side which intersect at 'O'.
- Join OA and AO is perpendicular to the line AB from the point 'A'.

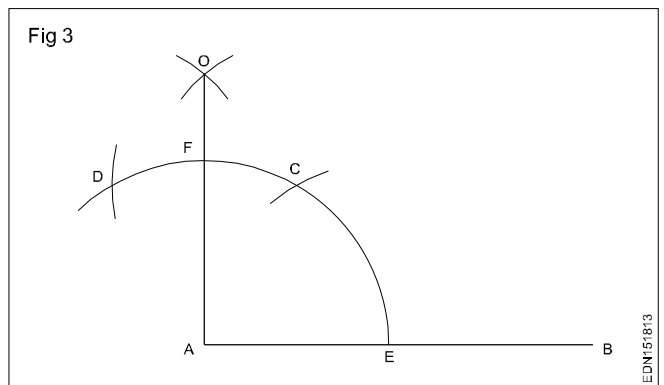

**4 Draw a line parallel to a given line at a given distance (Fig 4).**

- Draw a line AB to a convenient length (say 60 mm).
- Draw a line CD (40 mm) is the given distance.
- Mark points 1 & 2 near A & B respectively.
- With 1 & 2 as centres CD as radius draw arcs.
- At 1 & 2 erect perpendiculars by using setsquares, meeting at E & F respectively.
- Join the points E & F.
- EF is parallel to AB at the given distance of CD.

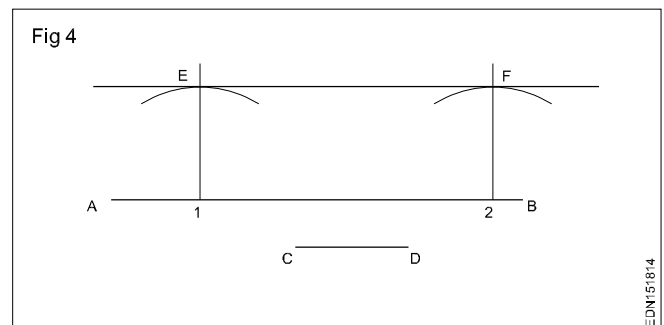

**5 Divide a line into any number of equal parts (Fig5).**

- Draw a line AB to a convenient length (say 65 mm).
- At 'A' draw a line AC to a required length, forming an angle BAC. (Always it is better to form an acute angle)

- Set off 5 equal arcs on the line AC meeting at 1,2,3,4 & 5. (As many equal parts as required)
- Join 5 & B.
- From the points 4,3,2 & 1 draw lines parallel to 5-B meeting the line AB at 4', 3', 2' & 1'.
- Now the line AB is divided into 5 equal parts.

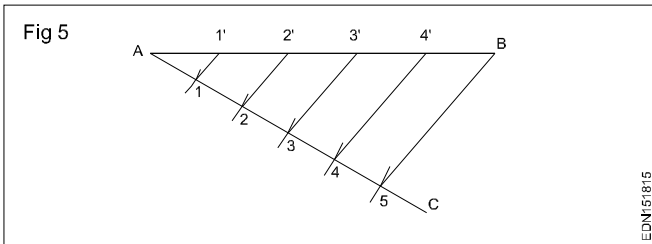

### 6 Trisect a given right angle (Fig 6).

- Draw a right angle ABC.
- With 'B' as centre to convenient radius, draw an arc meeting the line BC and BA at 1 & 2 respectively.
- With 1 & 2 as centres, B-1 as radius draw arcs to cut the previous arc at D & E respectively.
- Join BE & BD.
- Now  $\angle ABD = \angle DBE = \angle EBC$ .

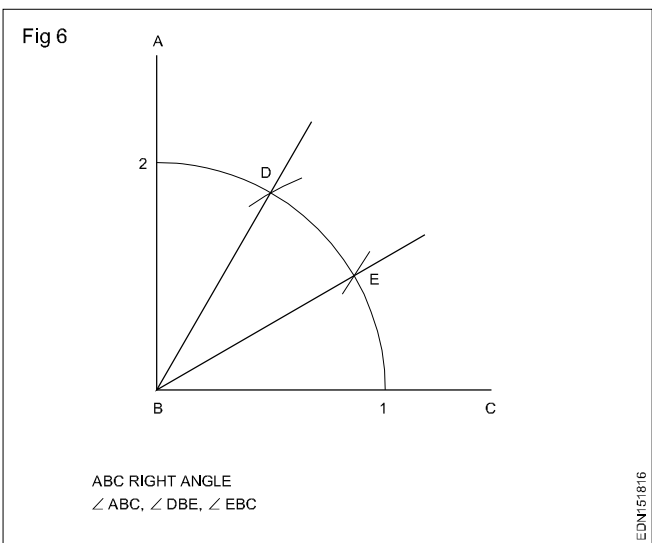

### 7 Bisect a given angle (Fig 7).

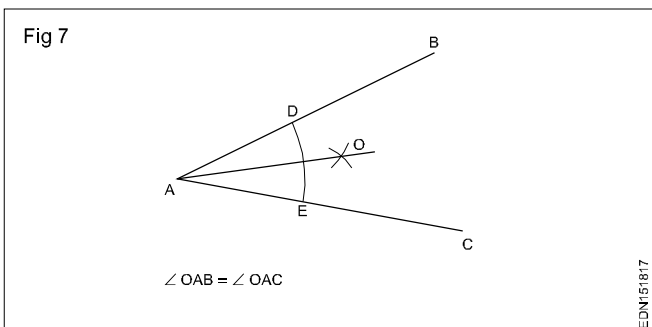

- Construct an angle BAC (say  $30^\circ$ ).
- 'A' as centre to a convenient radius draw an arc to cut line AC at 'E' and AB at 'D'.

- D and E as centre with the same radius draw arcs which intersect at point 'O'.
- Join AO.
- AO is the bisector of the angle BAC.
- Now  $\angle OAB = \angle OAC$ .

### 8 Construct an angle equal to $75^\circ$ (Fig 8).

- Draw a line BC (60 mm long).
- At 'B' erect a perpendicular GB and now  $\angle GBC$  is a right angle.
- Trisect the angle FBC at D & E.
- Bisect the angle FBD at 'A'.
- Now angle ABC =  $75^\circ$ .

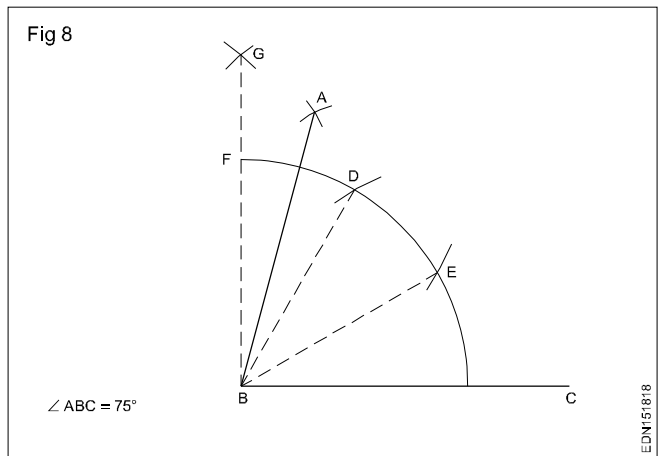

### 9 Construct an angle equal to $22\frac{1}{2}^\circ$ (Fig 9).

- Draw a line BC to a convenient length.
- At 'B' erect a perpendicular BD and  $\angle DBC$  is right angle.
- Bisect the  $\angle DBC$  at 'E'.
- $\angle DBE = \angle EBC = 45^\circ$
- Bisect  $\angle EBC$  at 'A'.
- Now  $\angle ABC = 22\frac{1}{2}^\circ$ .

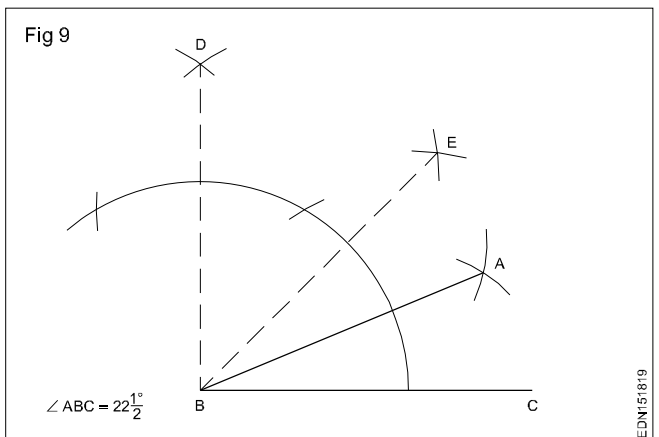

# Triangles

## Procedure

### 1 Equilateral triangle (Fig 1) $AB = BC = CA = 35$ mm.

- Draw a line and mark AB 35 mm the side of triangle.
- With radius AB and center A and B, draw arcs cutting at C (Fig 1).
- Join CA and CB.
- ABC is a required triangle.

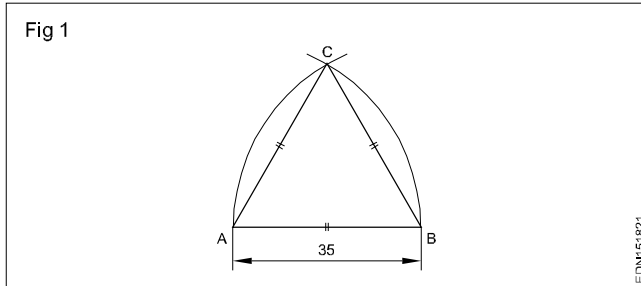

### 2 Isosceles triangle : $AB = AC = 40$ mm & $\angle BAC = 40^\circ$ .

- Draw the side AB equal to 40 mm. 'A' as centre, draw an arc of radius AB.
- Draw a line AC at  $40^\circ$  to AB.
- Join BC to form the triangle ABC. (Fig 2)

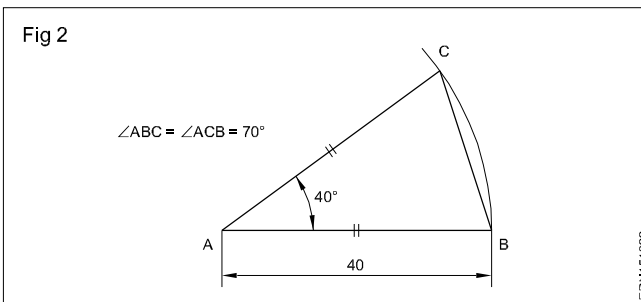

### 3 Isosceles triangle (Fig 3): Altitude = 40 mm & $\angle BCA = \angle BAC = 65^\circ$

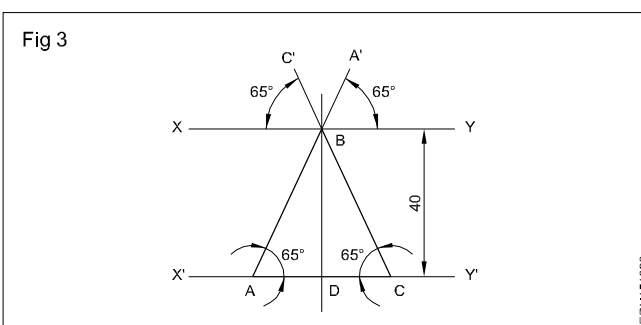

- Draw any line  $X'Y'$  and erect a perpendicular DB of height 40 mm at a convenient point 'D'.
- Draw a parallel line XY to  $X'Y'$  through 'B'.
- Draw  $A'B$  at  $65^\circ$  to XY and extend to meet at 'A' on the line  $X'Y'$ .
- Locate another point C on line  $X'Y'$  same way as in the previous step and complete the triangle ABC.

### 4 Scalene triangle: $AB = 30$ mm, $AC = 55$ mm & $BC = 35$ mm.

- Draw base AB = 30.
  - 'A' as centre draw an arc of radius 55.
  - 'B' as centre draw an arc of 35 cutting the previous arc at 'C'.
  - Join CA and CB.
- AB = 30, BC = 35 and AC = 55  
ABC is the required triangle. (Fig 4)

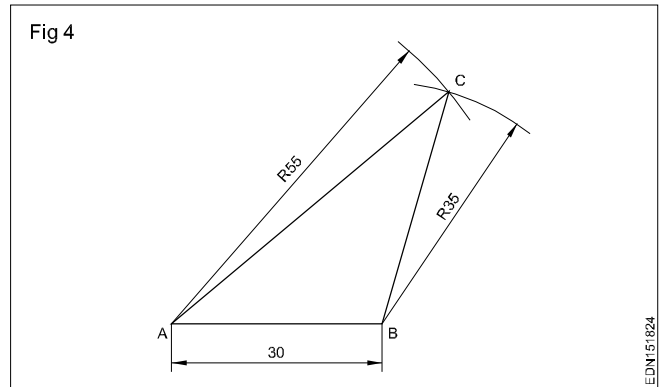

### 5 Scalene triangle: $AB = 40$ mm, $AC = 30$ mm & $\angle BCA = 30^\circ$ .

- Draw base AB (40 mm) and a perpendicular from its mid point.
- Set/draw the given angle  $30^\circ$  such that angle BAD =  $30^\circ$  (Angle C).
- Erect perpendicular to AD at 'A'.
- Extend both perpendiculars to meet at 'O'.
- AO as radius and 'O' as centre, draw a circle or an arc.
- Side AC (30 mm) as radius and 'A' as centre, draw an arc cutting the previous arc at 'C'.
- Join CA and CB.

ABC is the required triangle. (Fig 5)

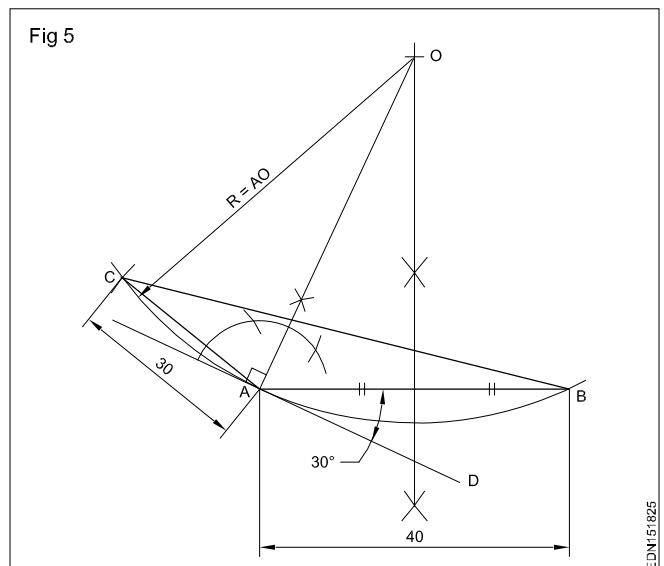

**6 Scalene triangle: AB = 70 mm**

$\angle ABC = 40^\circ$  &  $\angle BAC = 110^\circ$

- Draw line AB = 70
- Set  $110^\circ$  at 'A' using protractor.
- Set angle B =  $40^\circ$  using protractor. Extend the line meeting at 'C'. Join 'C' with A and B.

ABC is the required triangle. (Fig 6)

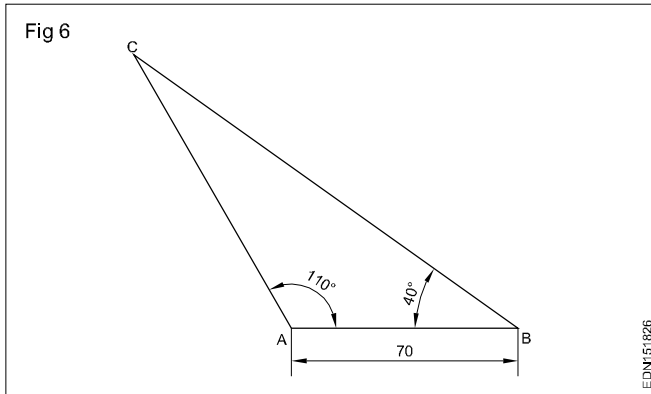

**7 Right angled triangle: AB = 60 mm, BC = 45 mm**

- Draw the horizontal line BC to length 45 mm.
- Erect a perpendicular to length 60 mm at 'B'.
- Join AC.

ABC is the required triangle. (Fig 7)

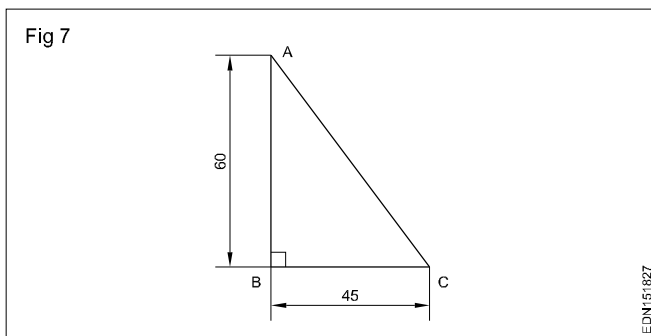

Construct triangles as per the procedure with given dimensions.

- 8 Draw an equilateral triangle ABC of sides 35 mm.
- 9 Draw an isosceles triangle ABC in which sides AB and AC are equal to 40 mm and  $\angle BAC$  is equal to  $40^\circ$ .
- 10 Draw an isosceles triangle ABC in which the altitude BD = 40 mm and  $\angle BAC$  and  $\angle BCA = 65^\circ$ .
- 11 Draw a scalene triangle ABC in which the side AB = 30 mm; AC = 55 mm and BC = 35 mm.
- 12 Draw a scalene triangle ABC in which the side AB = 40; AC = 30 and the angle BCA =  $30^\circ$ .
- 13 Draw a scalene triangle ABC in which the side AB = 30 mm;  $\angle ABC = 40^\circ$  and  $\angle BAC = 110^\circ$ .
- 14 Draw a right angled triangle ABC in which the sides AB and BC are 60 and 45 mm respectively.

Follow the above said procedure and construct the exercises from 15 to 19.

15 Draw a triangle when one side and 2 angles being given (Fig 8).

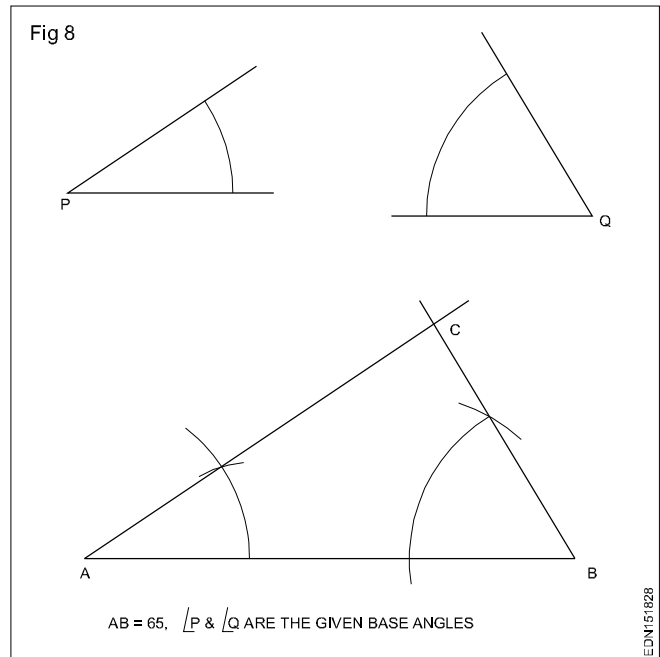

16 Draw a right angled triangle when the base and hypotenuse being given (Fig 9).

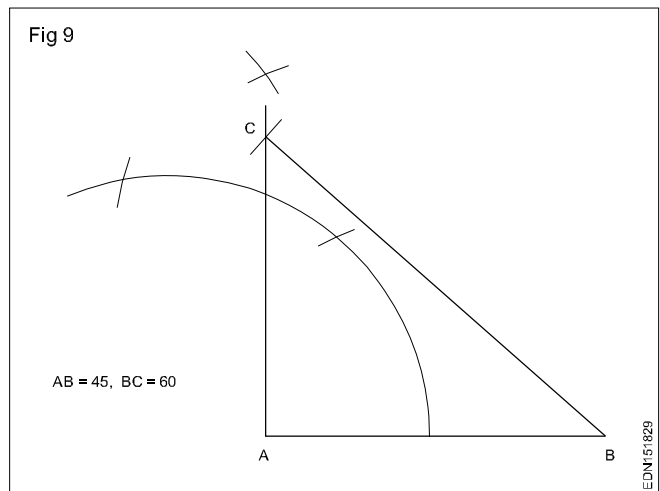

17 Draw a triangle the altitude and two sides being given (Fig 10).

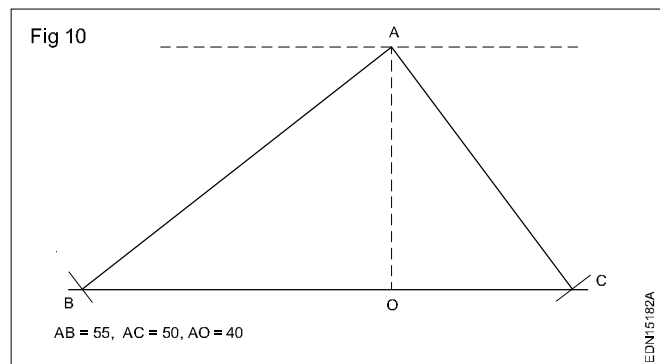

18 Draw a triangle the base, altitude and vertical angle being given (Fig 11).

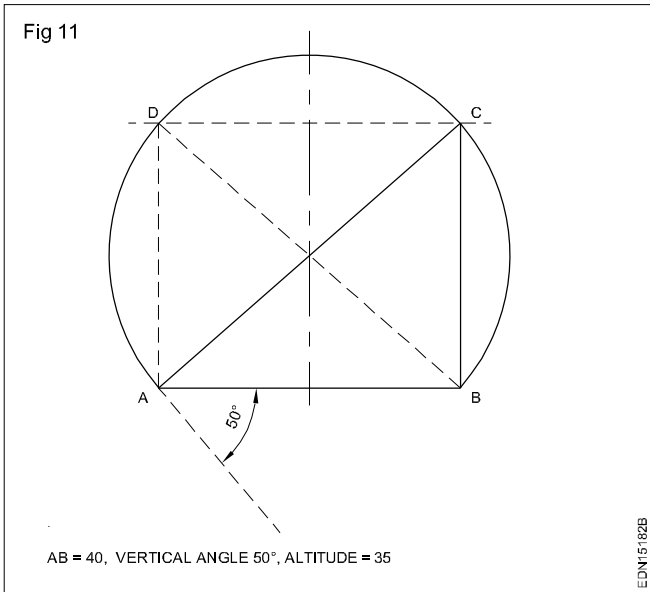

19 Draw a triangle the base, altitude and one side being given (Fig 12).

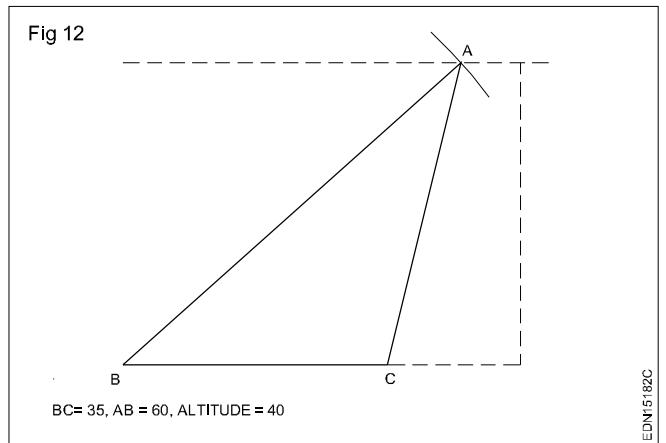

**Geometrical figures - Square, rectangle, rhombus, parallelogram, circle and its elements**

Quadrilateral is a plane figure bounded by four sides and four angles. Sum of the four angles in a quadrilateral is (interior angles) equal to  $360^\circ$ . The side joining opposite corners is called diagonal. To construct a quadrilateral out of four sides, four angles and two diagonals a minimum of five dimensions are required of which two must be sides. Quadrilaterals are also referred as Trapezium. (Fig 1)

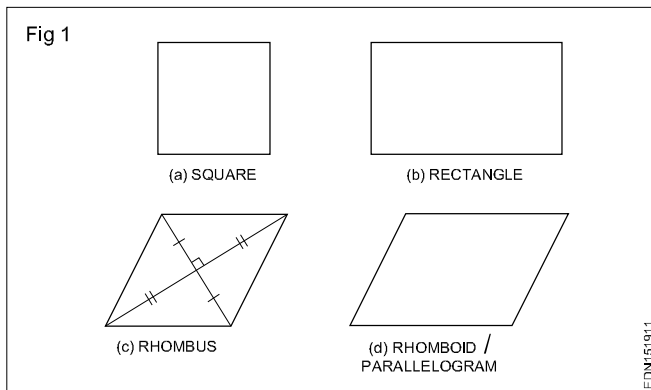

**Types of quadrilaterals (Fig 1)**

- Square
- Rectangle
- Rhombus
- Rhomboid/Parallelogram

**Square:** In a square all the four sides are equal and its four angles are at right angles. The two diagonals are equal and perpendicular to each other.

To construct a square we need to know (a) length of the side or (b) length of the diagonal.

**Rectangle (Fig 2):** In a rectangle, opposite sides are equal and parallel and all four angles are right angles.

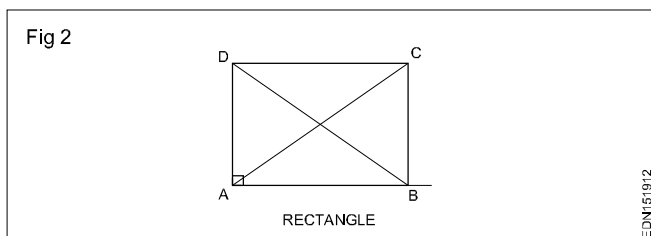

To construct a rectangle we need to know the length (a) two adjacent sides or (b) diagonal and one side.

Fig 2 shows a rectangle ABCD, Sides  $AB = DC$  and  $BC = AD$ . Diagonals AC and BD are equal. Diagonals are not bisect at right angles.

**Rhombus (Fig 3):** In rhombus all the four sides are equal but only the opposite angles are equal. ABCD is the rhombus where  $AB = BC = CD = AD$ .

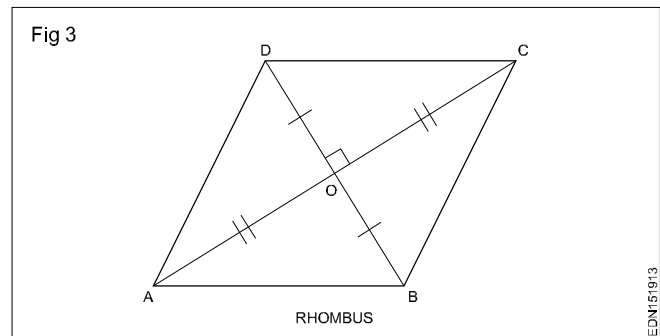

Angle  $ABC = \text{Angle } ADC$  and Angle  $BAD = \text{Angle } BCD$ .

Diagonals AC and BD are not equal but bisecting at right angles.

$AO = OC$  and  $BO = OD$ .

To construct a rhombus we need to know (a) two diagonals (b) one diagonal and an opposite angle or (c) one side and its adjacent angle.

**Rhomboid/Parallelogram (Fig 4):** In a parallelogram opposite sides are equal and parallel. Opposite angles are also equal. Diagonals are not equal but bisect each other.

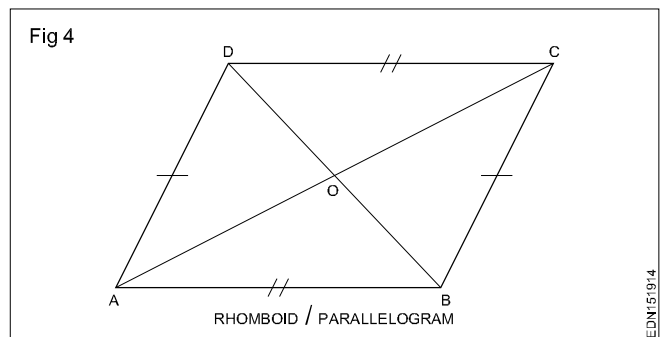

Parallelogram is also known as rhomboid. To construct a parallelogram we need (a) two adjacent sides and an angle between them or (b) one side, diagonal, and an angle between them or (c) two adjacent sides and perpendicular distance between the opposite sides.

In the parallelogram ABCD,  $AB = DC$ ;  $AD = BC$

Angle  $DAB = \text{angle } DCB$ , angle  $ABC = \text{angle } ADC$

Sides AB, CD and AD, BC are parallel.

Diagonals AC and BD are not equal but bisect at O.



# Circles, Tangents

**Circle:** Circle is a plane figure bounded by a curve, formed by the locus of a point which moves so that it is always at a fixed distance from a stationary point the "Centre".

**Radius:** The distance from the centre to any point on the circle is called the "Radius".

**Diameter:** The length of a straight line between two points on the curve, passing through the centre is called the "Diameter". (D: Dia or d) It is twice the radius.

**Circumference:** It is the linear length of the entire curve, equal to  $\pi D$ .

**Arc:** A part of the circle between any two points on the circumference or periphery is called an 'Arc'.

**Chord:** A straight line joining the ends of an arc is called the chord. (Longest chord of the circle is the diameter)

**Segment:** A part of the circle or area bound by the arc and chord is the segment of the circle.

**Sector:** It is the part of a circle bounded by two radii (plural of radius) meeting at an angle and an arc.

**Quadrant:** Part of a circle with radii making  $90^\circ$  with each other is a quadrant (one fourth of the circle).

Half of the circle is called as semi-circle.

**Tangent:** Tangent of a circle is a straight line just touching the circle at a point. It does not cut or pass through the circle when extended. The point where the tangent touches the circle is called the "point of tangency". The angle between the line joining the centre to the point of tangency and the tangent is always  $90^\circ$ .

Fig 1 shows all the above elements.

**Concentric circles:** When two or more circles (drawn) having common centre, they are called concentric circles. Ball bearing is the best example of concentric circles. (Fig 2)

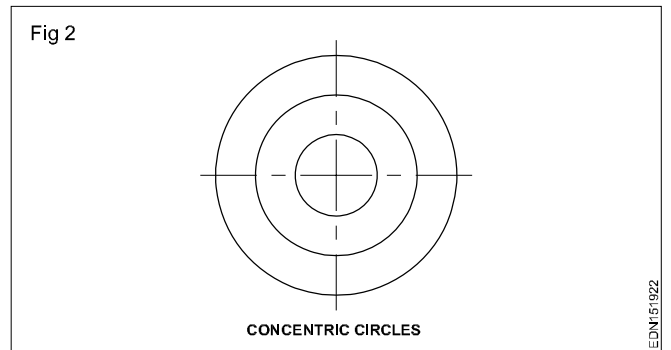
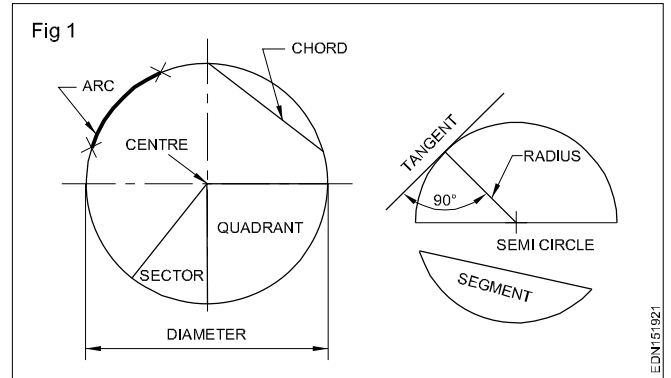

**Eccentric circles:** Circles within a circle but with different centres are called eccentric circles. (Fig 3)

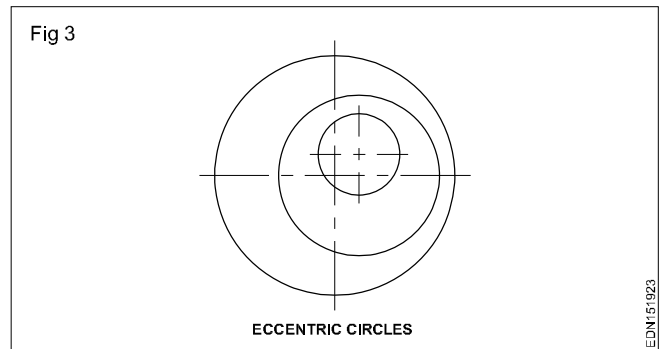

**Drawing of geometrical figures - Practice of square, rectangle, parallelogram, rhombus and circle**

Follow the procedures and construct quadrilaterals on A3/ A4 sheets.

**Procedure**

**Square**

**1 1st method (Fig 1):** A square of side 50 mm by erecting perpendicular.

- Draw a line AB 50 mm long.
- 'A' as centre, draw an arc of convenient radius 'r' touching the line AB at 'P' as shown in Fig 1.
- 'P' as centre and radius 'r' draw another arc cutting the earlier drawn arc at 'Q'.
- 'Q' as centre and radius 'r', draw another arc cutting at 'R'.
- Bisect QR at S and extend.
- Mark 50 mm on AS extended line. AD = 50 mm.
- From points B and D, draw parallels to AD and AB and complete the square ABCD.

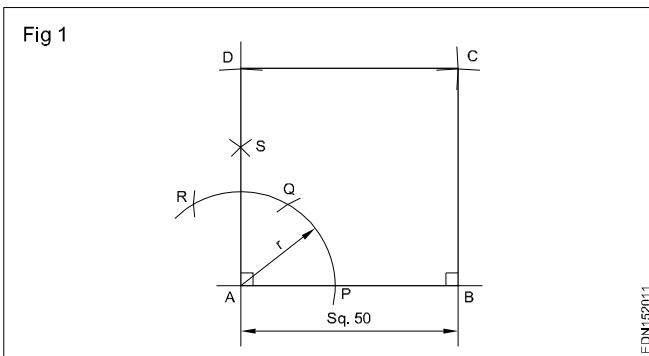

**2 2nd method (Fig 2):** A square of side 60 mm using 45° setsquare and compass.

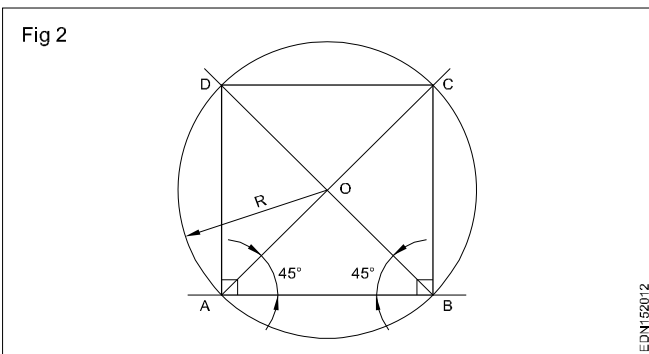

- Draw a horizontal line AB = 60 mm long.
- From points A and B, using 45° setsquare, draw 45° lines both intersecting at 'O'.

Draw a circle of radius OA or OB with centre 'O'.

- 'A' as centre and AB as radius, draw an arc. The arc cuts the circle at D.
  - Similarly draw an arc with centre D with radius AB and get point C.
  - Join AD, DC & CB and complete the square.
- 3 3rd method (Fig 3):** A square of side 60 mm long by erecting perpendicular and also using 45° setsquare.
- Draw line AB equal to 60 mm.
  - Erect perpendicular from A and B using 60° or 45° setsquare.
  - Draw 45° from A and B, cutting perpendicular lines at C and D.
  - Join A,D,C and B. ABCD is required square.

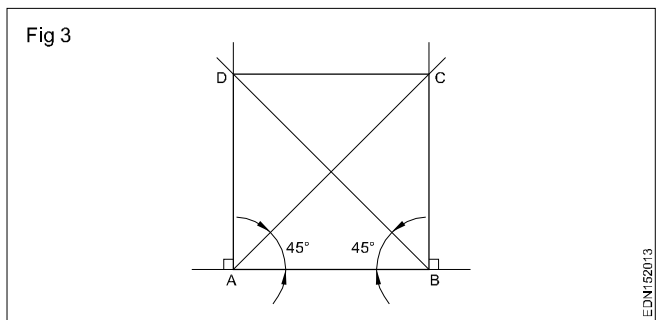

**4 Square having diagonal 60 mm (Fig 4)**

- Draw horizontal and vertical centre lines intersecting at 'O'.
- 'O' as centre, draw a circle of radius 30 mm passing through centre lines at A,B,C and D.
- Join points A-B, B-C, C-D and D-A. ABCD is the required square, whose diagonal is 60 mm.

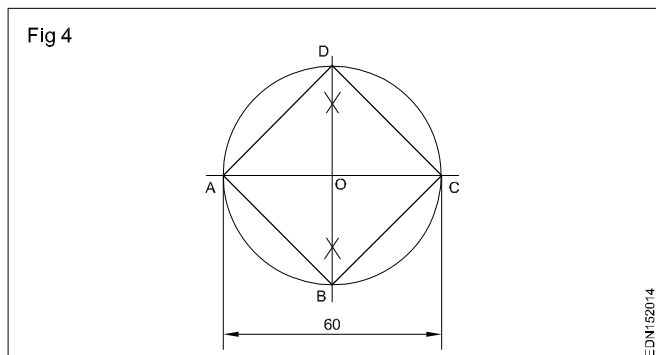

### 5 Rectangle (Fig 5)

Side AB = 75 mm, side AD = 45 mm using setsquare and compass.

- Draw the side AB equal to 75 mm.
- Erect perpendiculars at A and B.
- Mark off a height 45 from A and B, at D and C.
- Join C and D to complete the rectangle.

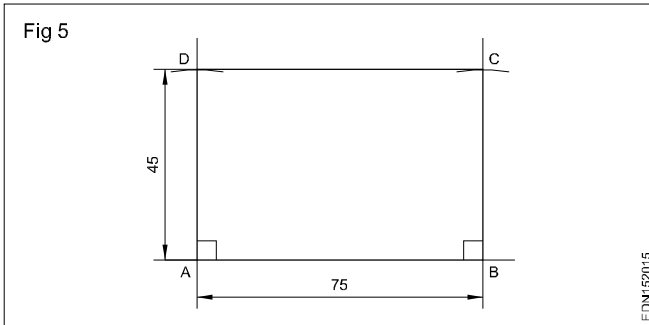

### 6 Rectangle - Diagonal - 60 mm and one side 20 mm 1st method (Fig 6a)

- Draw a line AB 60 mm.
- Draw a circle with AB as its diameter.
- 'A' as centre, draw an arc of R20, cutting the circle at D.
- Join AD and BD.
- Draw AC parallel to DB.
- Join BC and complete the rectangle.

### 2nd method (Fig 6b)

- Draw a line AD = 20 mm long.
- Draw perpendiculars from A and D upwards.
- A and D as centres, draw arcs of 60 mm radius cutting at B and C.
- Join BC.

ADBC is the required rectangle of side 20 mm and diagonal 60 mm.

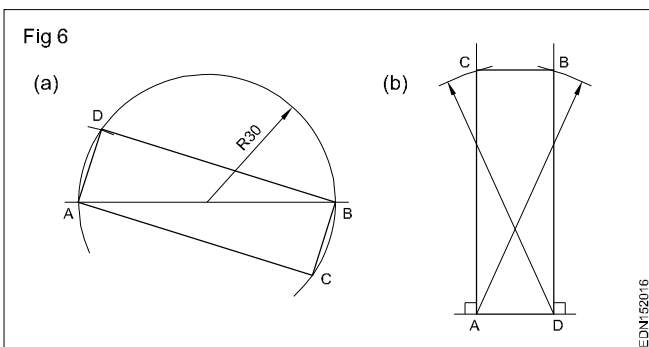

### 7 Parallelogram (Fig 7)

Sides = 75 mm and 40 mm

Angle between them: 50°

- Draw line AB 75 mm long.
- Draw line AD equal to 40 mm and 50° angle to AB.

- D as centre, draw an arc of radius equal to AB.
- 'B' as centre, draw an arc of radius equal to AD, upwards such that they meet at a point 'C'.
- ABCD is the required parallelogram.

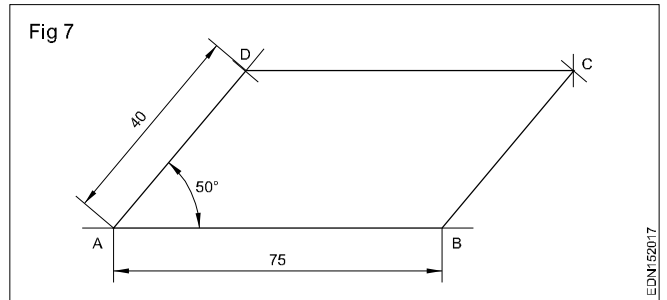

### 8 Parallelogram (Fig 8)

Parallelogram - Side AB = 60 mm

Diagonal AC = 90 mm ∠ABC = 120°

- Draw a line AB = 60 mm.
- Draw a line from B at angle of 120° to AB.
- 'A' as centre with radius 90 mm, draw an arc cutting 120° line from B at C.
- 'C' as centre, radius = AB, draw an arc.
- Similarly 'A' as centre and BC as radius, draw another arc, both arcs meet at 'D'.
- Join AD and DC.

ABCD is the required parallelogram.

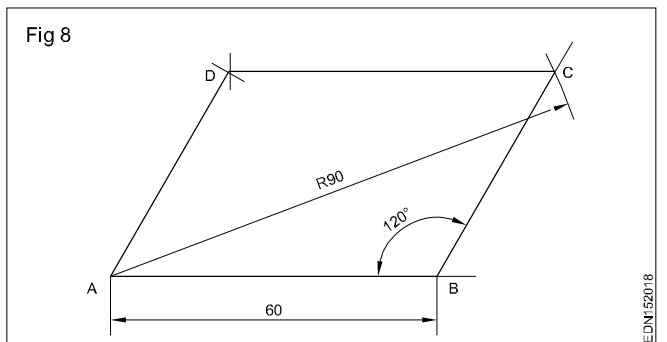

### 9 Parallelogram (Fig 9)

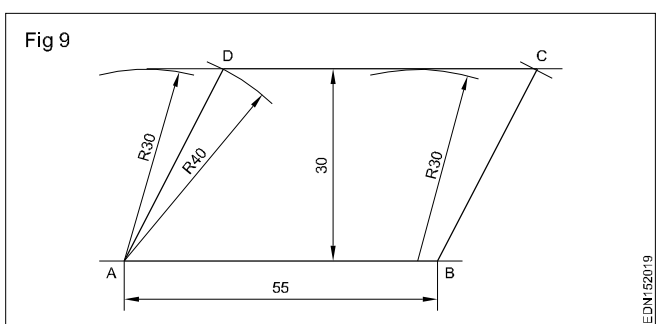

Sides AB = 55 mm, BC = 40 mm and vertical height = 30 mm.

- Draw the line AB 55 mm long.
- A and B as centres and radius (R) 30 mm, draw arcs above the line.

- Draw a common tangential line (parallel to base AB) to the arcs.
- A and B as centers, draw an arc of 40 mm radius cutting the line at D and C.

ABCD is the required parallelogram.

**10 Rhombus (Fig 10)**

Diagonals AB = 80 mm

CD = 50 mm

- Draw a line AB equal to 80 mm
- Draw perpendicular bisector of AB, passing through O.
- mark OC = OD = 25 mm.
- Join the points AC, CB, BD and DA to complete the rhombus.

**Check**

AC = CB = BD = DA i.e. all the 4 sides are equal.

Angle ACB = Angle ADB and

Angle CAD = Angle CBD

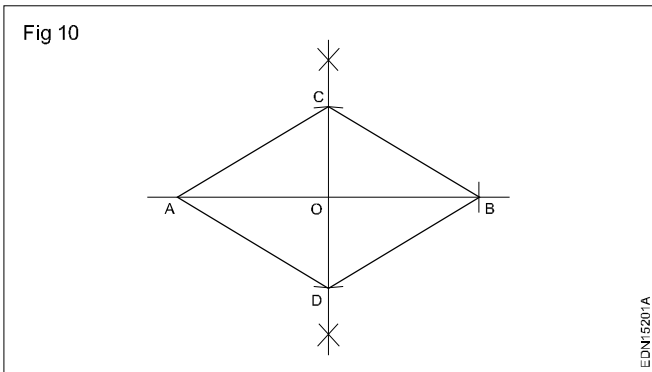

**11 Rhombus (Fig 11)**

Diagonal AB = 80 mm

∠ACB = 130°

Let the diagonal is equal to 80 mm and the angle is 130°.

Since sum of the angles in a triangle is 180°.

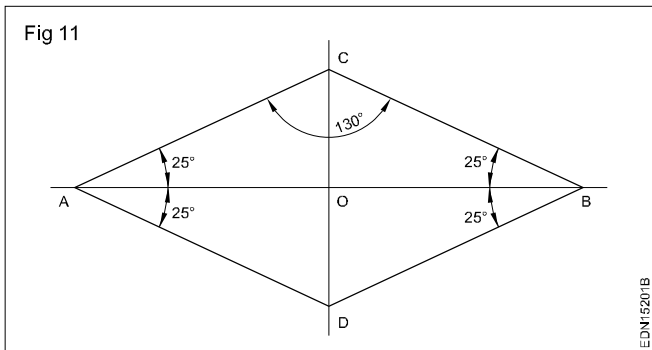

Angle ACB + Angle CBA + Angle CAB = 180°

Therefore Angle CAB = Angle CBA =

$$\text{Angle CAB} = \frac{180^\circ - 130^\circ}{2} = 25^\circ$$

- Draw the diagonal AB equal to 80 mm.
- Set an angle of 25° at A and B and draw the lines, meeting at C.
- Join AC and BC.
- Draw AD parallel to CB.
- Draw BD parallel to CA.

ABCD is the required rhombus.

**Check**

Join CD cutting AB at O measure

AO = OB; CO = OD

All the four angles at O are right angles.

**Further practice**

- 1 Construct a square of side 50 mm using compass and setsquare.
- 2 Construct a square whose diagonal is 60 mm using compass and setsquare.
- 3 Construct a rectangle given diagonal and side are equal to 60 mm and 20 mm.
- 4 Construct a rhombus of side 75 mm and one angle is 50°.
- 5 Construct a parallelogram given sides 75 and 40 mm angle 50°.
- 6 Construct a parallelogram given side 60 mm, diagonal 90 mm and angle 120°.

Draw the pattern drawings given in the workbook.

1

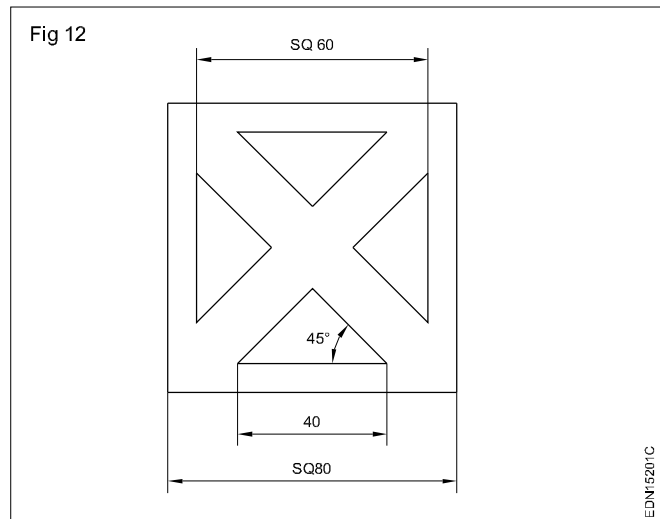

2

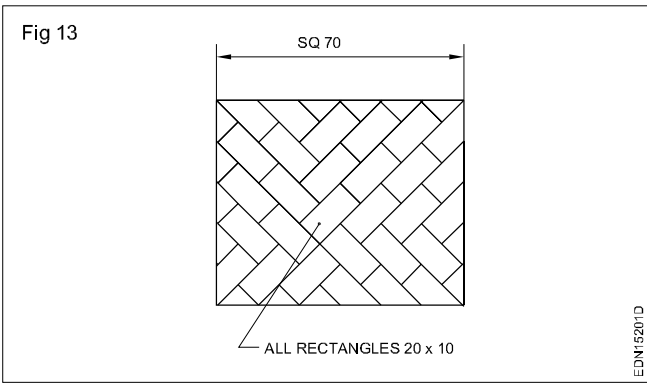

3

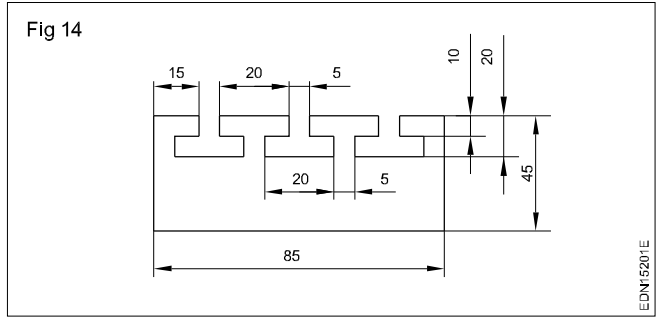

## Circles and arcs

Follow the procedures and construct the following in the work book practice sheets of Ex.No.1 to 12.

### Procedure

**1 Draw a tangent to a given circle of  $\phi$  50 mm at any point 'P' on it. (Fig 1)**

- Draw a circle of  $\phi$  50 with 'O' as centre.
- Mark the given point 'P' on the circumference of the circle.
- Join OP.
- Draw a line RS perpendicular to PO through 'P'.
- RS is the tangent at 'P'.

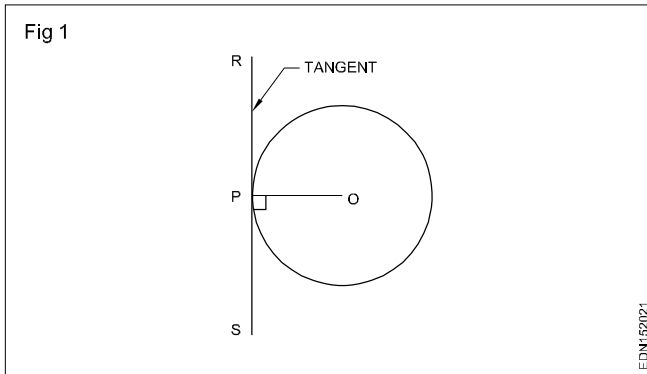

**2 Draw an arc of given radius (R 20 mm) to touch to two straight lines (50 mm each) at right angles. (Fig2)**

- Draw the lines AB and AC (50 mm each) at right angles.
- With 'A' as centre and given radius (R 20 mm) draw an arc to cut lines AB and AC at E and F.
- With E and F as centres and the radius given (R 20 mm), draw arcs to intersect each other at 'O'.
- Use 'O' as centre and with same radius (R 20) draw a curve (arc) which will just touch the given lines AB and AC.

Fig 2

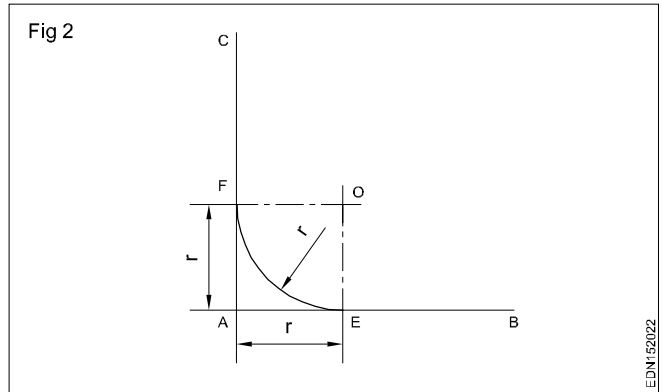

**3 Draw an arc of given radius (R 20 mm) to touch the given lines which make an acute angle between them (assume 60°). (Fig 3)**

- Draw an acute angle BAC (60°).
- Draw a horizontal parallel line EF at a distance equal to the given radius (20 mm).
- Draw another angular parallel line GH at a distance of given radius 20 mm. Both the parallel lines drawn meet at 'O'.
- With 'O' as centre and 'r' as radius (20 mm) draw an arc touching both lines AB and AC.

Fig 3

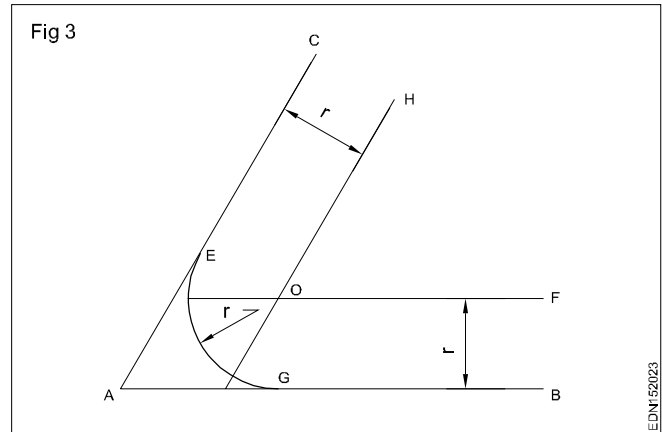

**4 Draw a loop of 3 circles pattern. (Fig 4)**

- Draw any line MN and mark points A,B and C. So that AB = 20 mm and BC = 25 mm.
- With 'A' as centre draw concentric circles of dia 15 mm and dia 20 mm.
- With 'B' as centre draw concentric circles of  $\phi$  20 mm and  $\phi$  25 mm.
- With 'C' as centre draw concentric circles of  $\phi$  25 mm and  $\phi$  30 mm.
- Erase unwanted part of the circles to form the pattern.

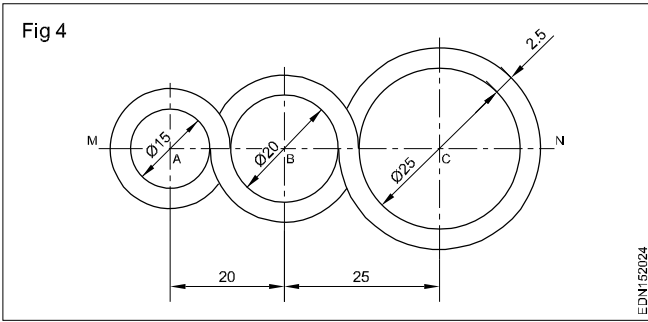

**5 Draw the cam as per dimensions given. (Fig 5)**

- Draw a vertical line and mark the points  $C_1, C_2$  such that  $C_1C_2 = 84$  mm.
- $C_1$  as centre, draw an arc of radius 56 mm ( $100-44$ ) and  $C_2$  as centre, draw another arc of radius 78 mm ( $100-22$ ). Both arcs cut at  $C_3$ .
- Similarly obtain a point  $C_4$  by drawing two arcs of radii 84 mm ( $44 + 40$ ) and 62 mm ( $22 + 40$ ) from points  $C_1$  and  $C_2$ .
- Draw a circle of radius 44 mm with  $C_1$  as centre and draw a circle of radius 22 mm with  $C_2$  as centre.
- Produce  $C_1C_2$  and get points A and B.
- $C_3$  as centre and radius  $BC_3$  (100 mm) draw an arc.
- $C_4$  as centre and radius 40 mm draw an arc.
- Draw a circle of R10 with centre  $C_2$ .
- Rub off the unwanted lines and complete the pattern.

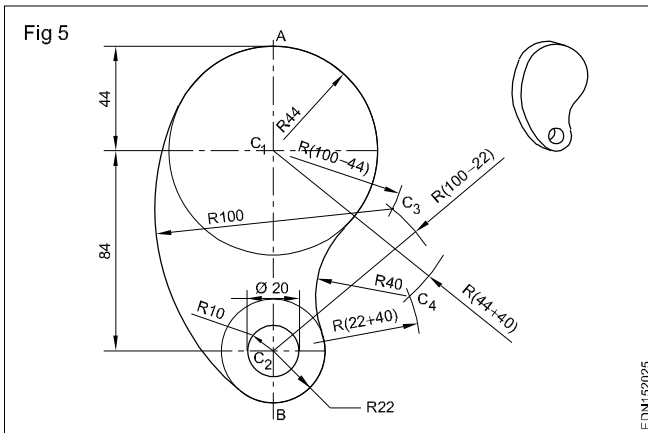

**6 Draw three circles tangential to each other if centres A,B & C are given. (Fig 6)**

- Mark centres A,B & C.
- Join AB, BC & CA and form triangle ABC.
- Bisect any two angles of the triangle. Bisectors cut the opposite sides AB and BC at F and G.
- 'A' as centre and AF as radius draw a circle.
- 'B' as centre and BF or BG as radius draw another circle.
- 'C' as centre and CG as radius draw the third circle.

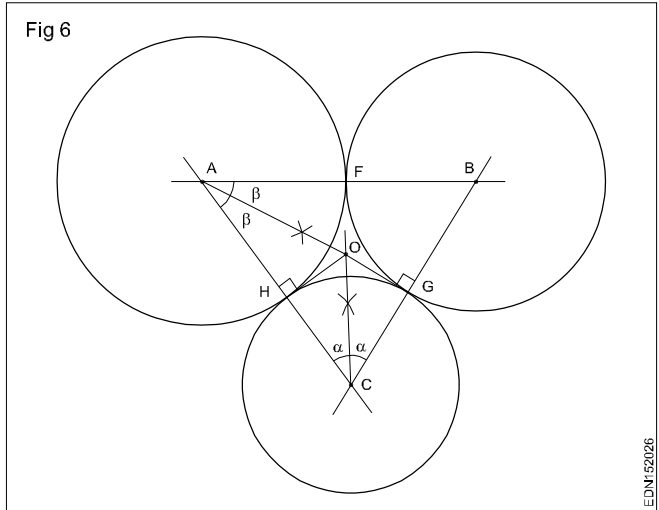

**7 Draw external tangents to circles of dia 40 and 30 and centre distance 60 mm. (Fig 7)**

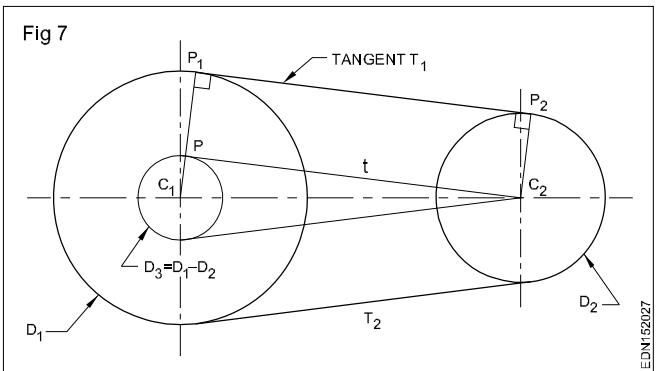

- Draw a line and mark two points  $C_1$  and  $C_2$  at 60 mm.
- Draw two circles of dia 40 and dia 30 with centre marked as  $C_1$  and  $C_2$ .
- On dia 40 circle ( $D_1$ ) draw a concentric circle of dia 10 ( $D_3$ ) (dia 40 - dia 30).
- From centre  $C_2$  draw a line 't' touching circle  $D_3$  at P.
- Join  $C_1$  and P (angle P is right angle).
- Extend line  $C_1, P$  upto the circle  $D_1$  meeting at  $P_1$ .
- Draw  $C_2P_2$  parallel to  $C_1P_1$ .
- Join  $P_1$  and  $P_2$  forming the (common) tangent  $T_1$  to circle  $D_1$  and  $D_2$ .
- Similarly draw tangent  $T_2$ . Tangents  $T_1$  and  $T_2$  are called external tangents.

**8 Draw internal tangents to circles of same diameter 40 each and centre distance 60 mm. (Fig 8)**

- Mark two points  $C_1$  and  $C_2$  60 mm apart.
- Draw circles of  $\phi$  40mm with centres  $C_1$  and  $C_2$ .
- Mark 'A' the midpoint of  $C_1C_2$ .
- Bisect  $C_1A$  and mark it as B.
- 'B' as centre  $C_1B$  as radius, draw an arc and get points  $P_1$  and  $P_2$ .
- 'A' as centre  $AP_1$  as radius, draw an arc and get points  $P_3$  and  $P_4$ .
- Join  $P_1P_4$  and  $P_2P_3$ .
- Mark them as  $T_1$  and  $T_2$ , the internal tangents.

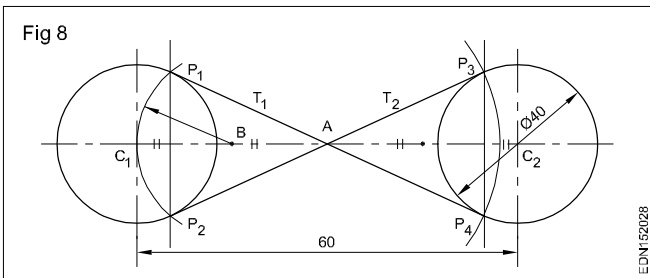

**9 Draw tangential curves for the circles of diameters 30 mm, 20 mm and centre distance 60mm. (Fig 9)**

- Mark centres  $C_1$  and  $C_2$  at a distance of 60 mm.
- Draw the given circles of dia 30 and dia 20 on  $C_1$  and  $C_2$ .
- $C_1$  as centre and radius 35 ( $R15 + R20$ ), draw arcs on either side of horizontal centre line.
- $C_2$  as centre and radius 30 ( $R10 + R20$ ), draw arcs cutting the arcs  $R35$  at  $C_3$  and  $C_4$ .
- $C_3$  and  $C_4$  as centers, with  $R20$ , draw arcs forming the arc tangential curves to the circles.

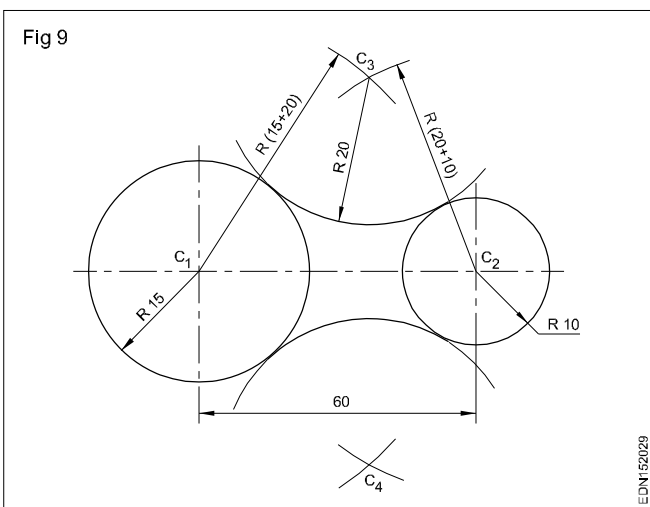

**Draw the figures in A3/A4 Sheets (Fig 10 - Fig 12)**

**10**

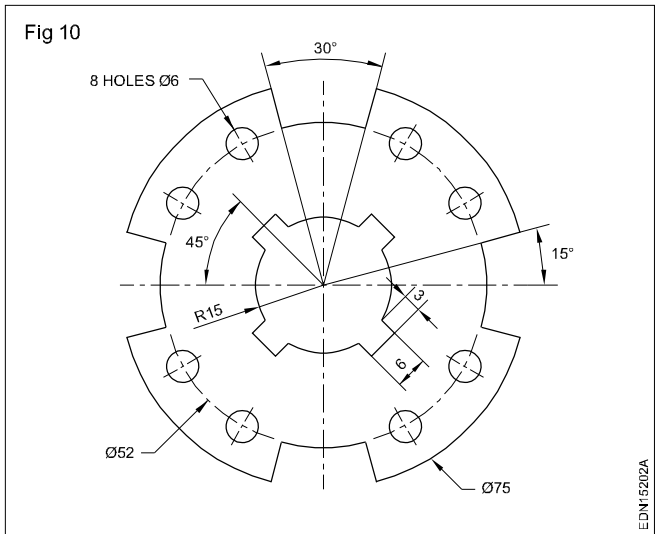

**11**

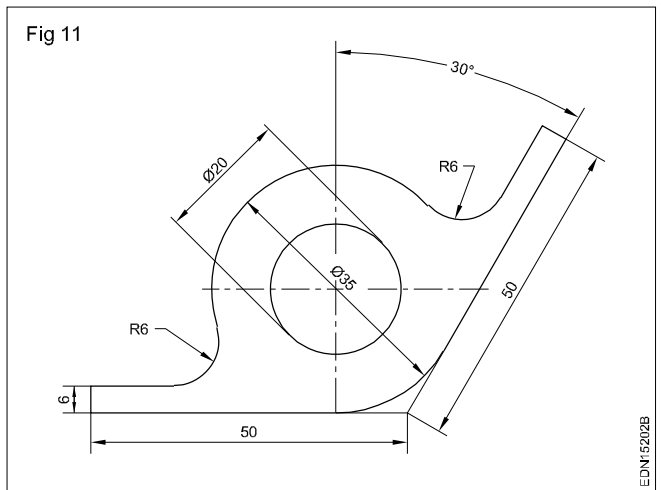

**12**

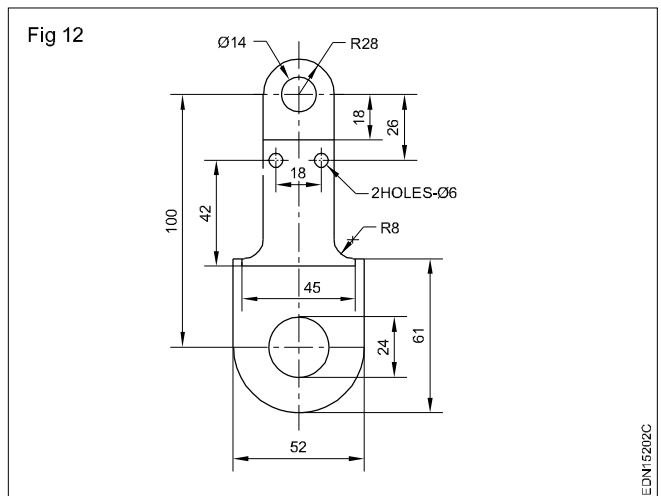



**Drawing of geometrical figures - Different polygons and their values of included angles. Inscribed and circumscribed polygons**

Polygon is a plane figure bounded by many (usually five or more) straight lines. When all the sides and included angles are equal, it is called as a regular polygon. (Fig 1)

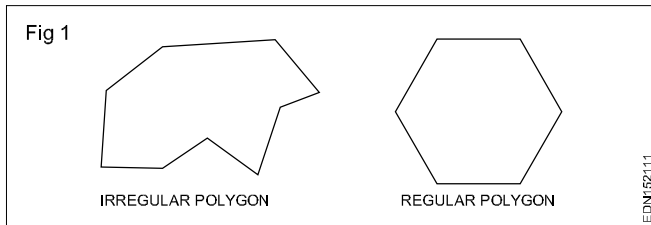

**Names of polygons:** Polygons are named in terms of their number of sides as given below: (Fig 2)

Name	No. of sides
Pentagon	Five sides
Hexagon	Six sides
Heptagon	Seven sides
Octagon	Eight sides
Nonagon	Nine sides
Decagon	Ten sides
Undecagon	Eleven sides
Duodecagon	Twelve sides

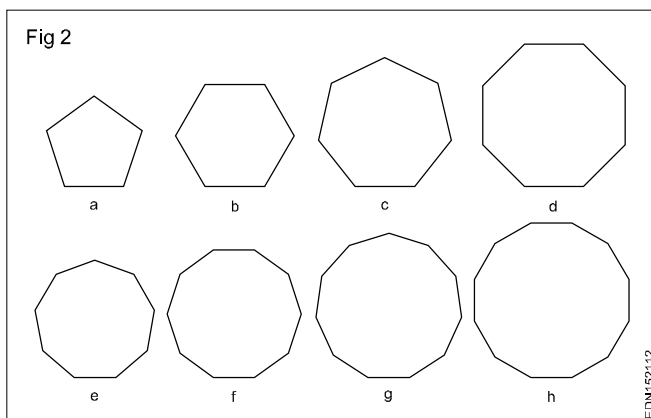

**Properties of polygon**

- All corners of a regular polygon lie on the circle. The sides of a regular polygon will be tangential to the circle drawn in side. (Fig 3)
- The sum of the interior angles of a polygon is equal to  $(2 \times n - 2) \times 90^\circ$ , where n is the number of sides.
- The sum of exterior angles of a polygon is equal to  $360^\circ$ .
- The sum of the interior angle and the corresponding external angle is  $180^\circ$ . (Fig 4)

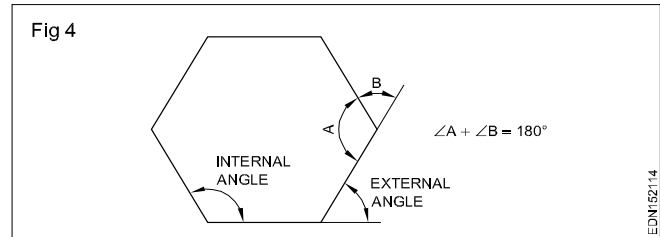
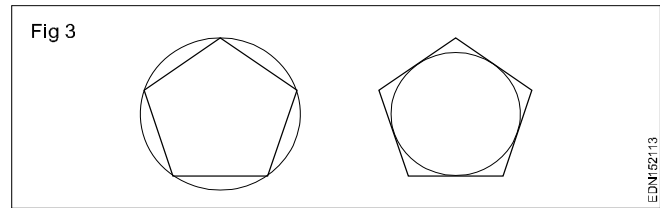

**Inscribed polygon**

An Inscribed polygon might refer to any polygon which is inscribed in a shape. A cyclic polygon, which is inscribed in a circle (the circumscribed circle). A midpoint polygon of another polygon.

**Circumscribed Polygon**

A Circumscribed polygon is a polygon in which each side is a tangent to a circle. The circle is inscribed in the polygon and the polygon is circumscribed, about the circle (It is a circle in a polygon).

Circumscribed literally means 'to draw around' a circumscribed circle of a triangle for example is the circle that passes through all three vertices, usually called the circumcircle.

A Circumferential figure is a shape drawn outside another shape. For a polygon to be inscribed inside a circle all of its corner, also known as vertices, must touch the circle. If any vertex fail to touch the circle, then it is not called inscribed shape.

**Types of polygon**

**PROCEDURE**

- 1 Regular heptagon of side 25 mm.
  - Semi-circular method - Type A (Fig 5)
    - Draw a line AB equal to 25 mm.
    - Extend BA to a convenient length.
    - 'A' as centre and radius AB describe a semi-circle.
    - Divide the semi-circle into seven equal parts (number of sides) using divider.
    - Number the points as 1,2,3,4,5,6 starting from 'P'.
    - Join A2
    - Draw the perpendicular bisectors from 2A and AB intersecting at O.
    - 'O' as centre and OA or OB as radius describe a circle.



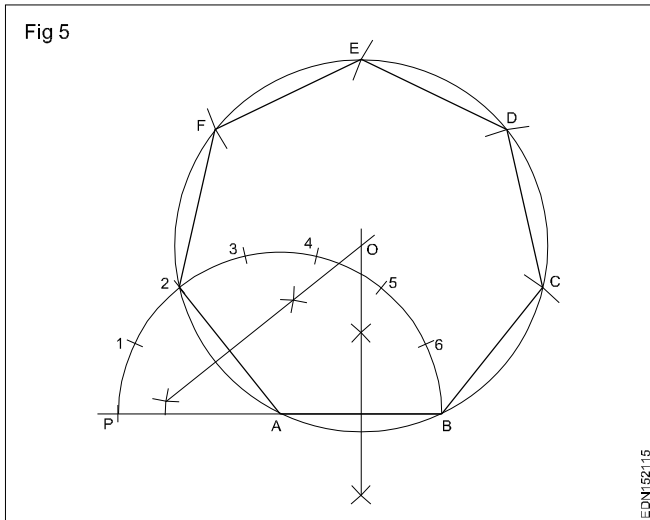

- Mark the points C,D,E,F and 2 on the circle such that  $BC = CD = DE = EF = F2 = AB$ .
- Join the line BC, CD, DE, EF and F2.
- ABCDEF2 is required heptagon.

### 2 Semi-circle method - Type B (Fig 6)

Follow the procedure upto dividing the semi-circle into number of equal parts. (Ex.1)

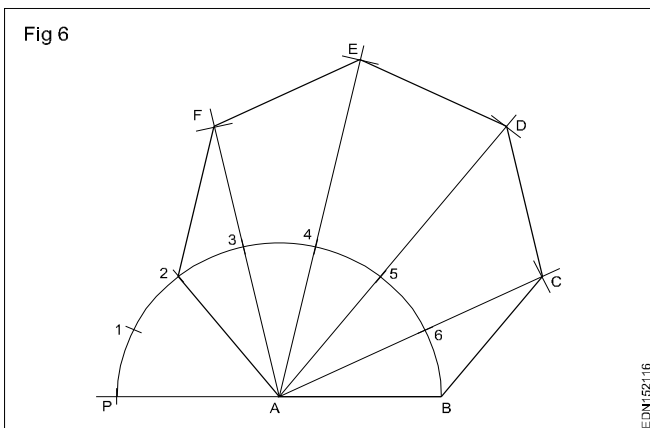

- Join A2
- Join A3, A4, A5 and A6 and extend to a convenient length.
- With centre 'B' and radius AB draw an arc cutting A6 extended line at 'C'.
- 'C' as centre and same radius, draw an arc cutting the line A5 at 'D'.
- Locate the points E & F in the same manner.
- Join BC, CD, DE, EF and F2.
- ABCDEF2 is the required heptagon.

### 3 Perpendicular bisector method. (Fig 7)

- Draw a semi-circle on line AB, the side of the polygon. (In this case it is heptagon)
- Draw a perpendicular bisector of AB which cuts the semi-circle at point '4'.
- Describe an arc with 'B' as centre and AB as radius. The arc cuts the perpendicular at '6'.

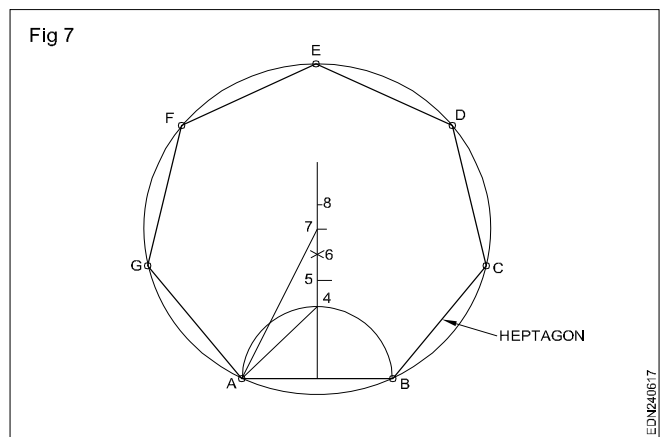

- Mark point '5' at the middle of points '4' and '6'.
- Set off 6-7 and 7-8 equal to 4-5.
- Point '7' as centre and 7-A as radius draw a circle.
- On the circumference set off BC, CD, DE, EF, FG and GA equal to AB.
- Join BC, CD, DE, EF, FG and GA and complete the heptagon.

### 4 Pentagon inside a circle of diameter 60 mm. (Fig 8)

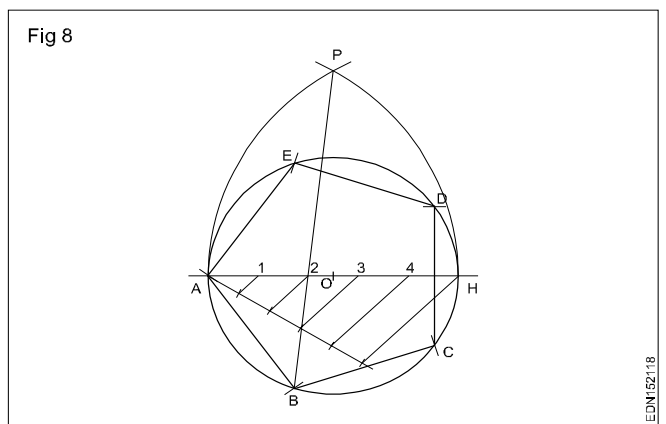

- Draw the line AH equals to 60 mm. (Diameter of circle)
- 'O' as centre OA as radius describe a circle.
- Divide AH into 5 equal parts (as many equal parts as the sides).
- A and H as centres, AH as radius describe arcs
- A and H as centres, AH as radius describe arcs intersecting at 'P'.
- Join P2 and extend it to meet the circle at 'B'.
- Set off BC, CD, DE, EF equals to AB on the circle.
- Join the points.
- ABCDEF is the required pentagon.

### 5 Pentagon outside a circle of diameter 50 mm. (Fig 9)

- O as centre and OF as radius describe a circle of dia 50 mm.
- Draw the line DF vertically beyond the top of the circle.

Fig 9

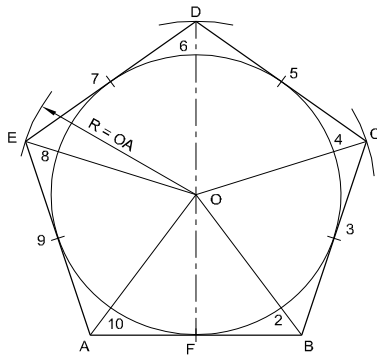

EDN152119

- Divide the circle into 10 equal parts. (Twice as many equal parts as the number of sides)
- Points 1,3,5,7 and 9 are the tangent points of the pentagon.
- Join 02, 04, 06, 08, 010 and extend to a convenient length.
- Draw a tangent to the circle through point 1 (F).
- The tangent cuts the lines 0-2 and 0-10 lines at A&B.
- In same manner draw tangents on points 3,5,7,9 & locate C,D & E.
- Join BC, CD, DE, EA
- ABCDE is the required pentagon.

6 Arc method

Hexagon of side 32 mm (Fig 10)

Fig 10

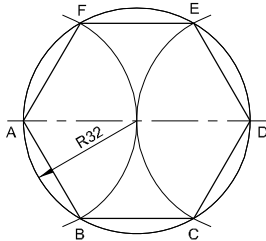

EDN15211A

- Draw a circle of radius 32 mm.
  - Mark the diameter AD
  - With same radius, A and D as centres. draw two arcs cutting the circle at points B,F,E & C respectively.
  - Join AB, BC, CD, DE, EF and FA.
- ABCDE is the required hexagon.

7 Arc method (Fig 11)

Hexagon inside a circle of diameter 60 mm (inscribing)

- Draw a line FC equal to 60 mm (Diameter of circle).
- 'O' as centre describe a circle on the diameter FC.
- F as centre FO as radius draw an arc at A.
- 'A' as centre, same radius draw an arc at B.
- In the same manner set the points C,D & E.
- Join AB, BC, CD, DE, EF and FA.

ABCDEF is the required hexagon.

Fig 11

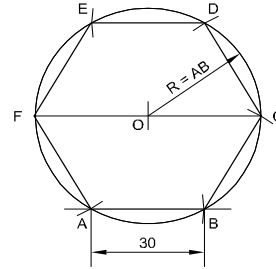

EDN15211B

8 Across flats method (Fig 12)

Fig 12

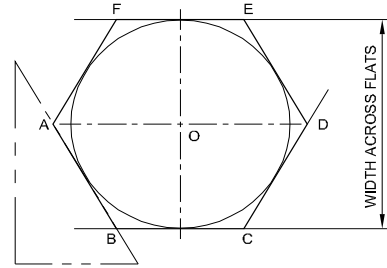

EDN15211C

Hexagon, distance across flat of 45 mm

- Draw a circle of  $\phi$  45. (45 mm is the size across flat)
  - Draw two horizontal tangents BC and FE.
  - With  $60^\circ$  setsquare draw four tangents, touching the horizontal tangents.
  - Mark the corners A,B,C,D,E and F.
- ABCDEF is the required hexagon.

8 Octagon special method (Fig 13)

Fig 13

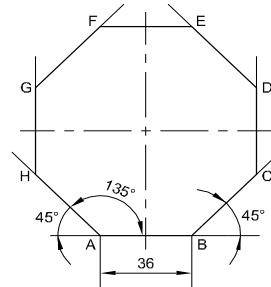

EDN15211D

Octagon of side 36 mm.

- Draw a horizontal line AB equals to 36 mm.
  - Set an angle of  $135^\circ$  (or  $45^\circ$ ) at A and B.
  - A and B as centres, with radius AB, draw arcs, cutting the lines at H and C.
  - Draw vertical lines from H and C upwards.
  - Mark length HG and CD equal to AB.
  - From point G draw a line GE parallel and equal to BC.
  - From point D draw a line DE parallel and equal to AH.
  - Join FE.
  - All the sides are equal and interior angles are equal.
- ABCDEFGH is octagon required.

**Lettering and numbering - Single stroke, double stroke and inclined**

Apart from graphical elements (lines, arcs, circles etc) technical drawings will also contain written informations.

These written informations are referred as "lettering".

**Styles of lettering:** Many styles of lettering are in use to day. However, a few styles which are commonly used are shown in figure 1.

Fig 1

<b>ABCDEFGH</b> <b>abcdefgh</b>	GOTHIC ALL LETTERS HAVING THE ELEMENTARY STROKES OF EVEN WIDTH ARE CLASSIFIED AS GOTHIC
<b>ABCDEFGH</b> <b>abcdefgh</b>	ROMAN ALL LETTERS HAVING THE ELEMENTARY STROKES "ACCENTED" OR CONSISTING OF HEAVY AND LIGHT LINES ARE CLASSIFIED AS ROMAN
<i>ABCDEFGH</i> <i>abcdefgh</i>	ITALIC ALL SLANTING LETTERS ARE CLASSIFIED AS ITALIC. THESE MAY BE FURTHER DESIGNATED AS ROMAN-ITALICS, GOTHIC-ITALICS, TEXT-ITALICS
<b>ABCDEF</b> <b>abcdef</b>	TEXT THIS TERM INCLUDES ALL STYLES OF OLD ENGLISH, GERMAN TEXT. BRADELY TEXT OF OTHERS OF VARIOUS TRADE NAMES. TEXT STYLES ARE TOO ILLEGIBLE FOR COMMERCIAL PURPOSES

EDN162211

**Standard heights/Width:** The standard heights recommended by BIS SP: 46-2003 are in the progressive ratio of "square root 2". They are namely 2.5 - 3.5 - 5 - 7 - 10 - 14 and 20 mm. The height of lower case letter (without tail or stem) are 2.5, 3.5, 5, 7, 10 and 14 mm.

There are two standard ratios for the line thickness "d". They are A & B. In A = line thickness (d) is h/14 and in B=line thickness (d) is h/10.

**Lowercase** means small letters, as opposed to capital letters. The word yes, is for example, is in **lowercase**, while the word YES is in **upper case**. For many programmes, this distinction is very important. Programmes that distinguish between **uppercase** and **lowercase** is said to be case sensitive

The width of different letters in terms of "d" is as follows:

**Lettering A**

Width (W)	Capital letters	Width
1	I	1d
5	J,L	5d
6	C,E,F	6d
7	B,D,G,H,K,N,O,P,R,S,T,U & Z	7d
8	A,Q,V,X,Y	8d
9	M	9d
12	W	12d

**Lower case letters and numerals**

Width (W)	Letters/Numerals	Width
1	i	1d
3	j,l	3d
4	f,t,l	4d
5	c,r	5d
6	a,b,d,e,g,h,k,n,o,p,q,s,u,v;3;5	6d
7	a,0 (zero), 2,4,6,7,0,8,9	7d
9	m	9d
10	w	10d

The width of different letters in terms of stroke (line) is as follows:

**Uppercase Lettering BIS SP: 46-2003**

Width (W)	Capital letters
1	I
4	J
5	C,E,F,L
6	B,D,G,H,K,N,O,P,R,S,T,U & Z
7	A,M,Q,V,X,Y
9	W

**Lower case letters and numerals**

Width (W)	Letters/Numerals
1	i
2	l
3	j,l
4	c,f,r,t
5	a,b,d,e,g,h,k,n,o,,q,s,u,v,x,y,x
	0,2,3,5 to 9
	0,2,3,5 to 9
6	a,4

Fig 2 & 3 shows the sequence of printing single stroke lower capitals and capital letters in vertical style.

Inclined letters (Fig 2) are drawn at an angle of 15° towards right side, the proportion being the same as of vertical lettering.

Fig 2 shows double stroke letters also.

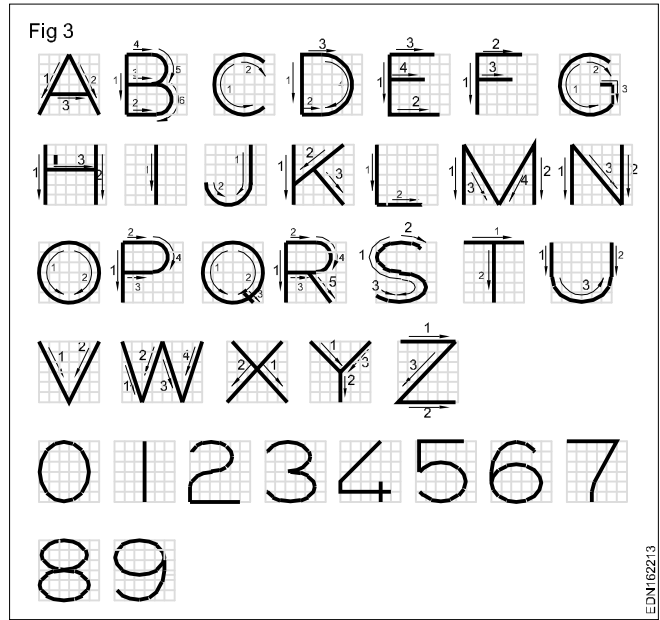
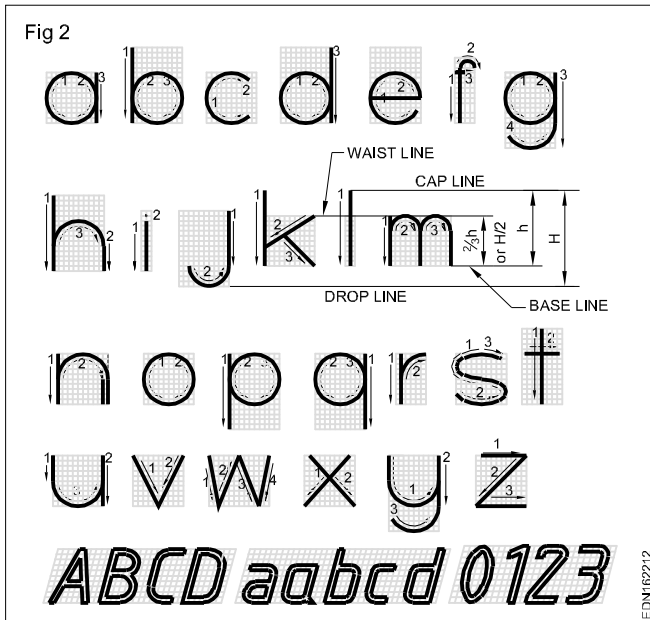

Standard letters to suit the nature of instructions, the sizes should be selected. All the lettering should be printed, so that they are read/viewed from the bottom of the drawing.

Lettering improves the appearance and legibility of the drawing. Always maintain uniform lettering (letters and numerals) which can be reproduced within reasonable time with ease. In machine drawing ornamental lettering should never be used.

**Spacing of letters:** Recommended spacing between character, minimum spacing of base lines and minimum spacing between words as per BIS SP: 46-2003 is given below in figure No.4 and Table 1 & 2.

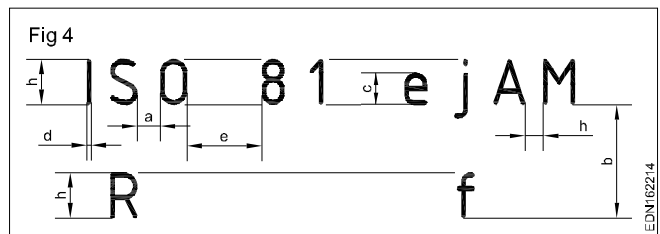

TABLE 1

Lettering A ( $d = h/14$ )	Characteristic	Ratio	Values in millimetres						
			Dimensions						
Lettering height	h	(14/14)h	2.5	3.5	5	7	10	14	20
Height of capitals									
Height of lower-case letters (without stem or tail)	c	(10/14)h	-	2.5	3.5	5	7	10	14
Spacing between characters	a	(2/14)h	0.36	0.5	0.7	1	1.4	2	2.8
Minimum spacing of base lines	b	(20/14)h	3.5	5	7	10	14	20	28
Minimum spacing between words	e	(6/14)h	1.06	1.5	2.1	3	4.2	6	8.4
Thickness of lines	d	(1/14)h	0.18	0.25	0.35	0.5	0.7	1	1.4

**Note:** The spacing between two characters may be reduced by half if this gives a better visual effect, as for example LA, TV; it then equals the line thickness d.

TABLE 2

Lettering B ( $d = h/10$ )			Values in millimetres						
Characteristic	Ratio		Dimensions						
Lettering height Height of capitals	h	(10/10)h	2.5	3.5	5	7	10	14	20
Height of lower-case letters (Without stem or tail)	c	(7/10)h	-	2.5	3.5	5	7	10	14
Spacing between characters	a	(2/10)h	0.5	0.7	1	1.4	2	2.8	4
Minimum spacing of base lines	b	(14/10)h	3.5	5	7	10	14	20	28
Minimum spacing between words	e	(6/10)h	1.5	2.1	3	4.2	6	8.4	12
Thickness of lines	d	(1/10)h	0.25	0.35	0.5	0.7	1	1.4	2

**Note:** The spacing between two characters may be reduced by half if this gives a better visual effect, as for example LA, TV: it then equals the line thickness d.

## Lettering

**Note:** Print letters/numerals in workbook (Ex.1 to 6) as instructed below:

### Procedure

- 1 Print 10 mm single stroke capital letters and numerals in vertical style using either scale or setsquare and by free hand.

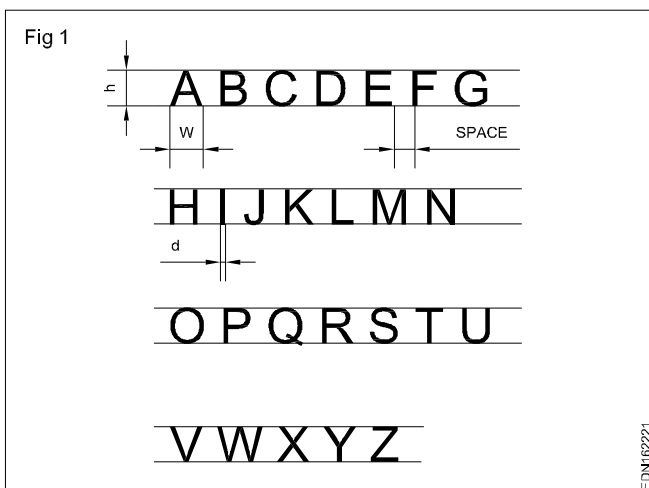

- Draw horizontal parallel lines (thin lines) of 10 mm distance.

**10 mm distances denotes the height of the letter.**

- Mark the width of the letters recommended by BIS (IS:9609-1983)

**The width of different letters in terms of 'd' is as follows: 'd' indicates stroke thickness i.e d: h/10.**

Width (W)	Capital letters
1	I
4	J
5	C, E, F, L
6	B, D, G, H, K, N, O, P, R, S, T, U & Z
7	A, M, Q, V, X, Y
9	W

For curved letters use smooth free hand curve.

Print straight line letters using either scale or setsquares.

To maintain the uniform thickness of line, use conical point soft grade pencil and avoid too much of sharpness.

Guidelines of both top and bottom should always be drawn with sharp pencil.

Numerals 2.1 (Fig 2)

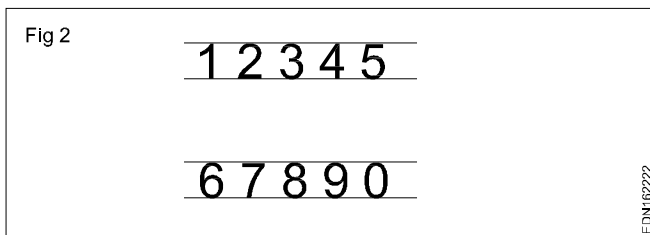

- Follow the same procedure of letters.
- 'h' is height of numerals and 'd' is the stroke thickness.
- Width of numerals in terms of 'd' is as follows shown in square grid (Fig 3).

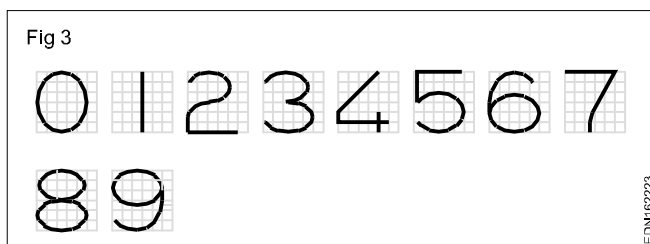

- 2 Print 10 mm single stroke capital letters and numerals in inclined style (Fig 4).

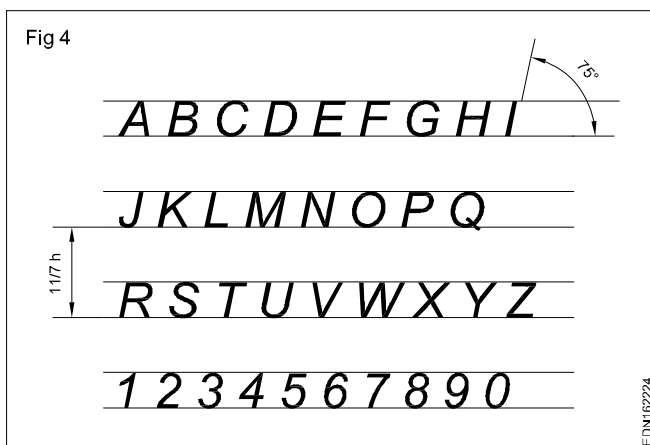

- Follow the same procedure of vertical capital letters and numerals.
  - Mark inclined lines at an angle of 15° towards right or 75° from horizontal.
- 3 Print letters and numerals, vertical and inclined style. Size 5 mm - Capital letters.
- 4 Print 5 mm lower case letters and numerals both in vertical and inclined style.

Refer lettering practice theory and complete the printing of letters and numerals.

5 Print the following statements in 5 mm size.

- 1 All dimensions are in mm
  - 2 Ask if in doubt
  - 3 Six holes diameter 8 mm equally spaced 60 mm pitch circle diameter.
  - 4 This drawing confirms to IS:9609-1983
  - 5 Bureau of Indian Standards (BIS) is our national standard.
  - 6 General deviations as per IS:2012 (medium)
  - 7 All thick lines - 0.5 mm
  - 8 Chamfer to bottom of thread.
  - 9 Rough mill the surface marked 'X'.
  - 10 Punch roll number and part number.
- Calculate the width of the each letters.
  - Draw the guidelines for the required size.
  - Mark the width and spacing for each letter.
  - Draw vertical guidelines.
  - Print the letter free hand, using HB pencil.

Print letters and numerals (1 to 5) according to the procedure given in theory book.

Practice 1 to 5

- 1 Print letters A to Z and numerals 1 to 0 in vertical style. 10 mm capital letters, 10 mm numerals.
- 2 Print letters A to Z and numerals 1 to 0 in inclined style. 10 mm capital letters, 10 mm numerals.
- 3 Print letters and numerals vertical and inclined style. 5 mm capital letters.
- 4 Print lower case letters 5 mm size in vertical and inclined style.
- 5 Print the following statements in 5 mm size letters and numerals.
  - All dimensions are in mm.
  - Six holes diameter 8 mm equally spaced 60 mm pitch circle diameter.
  - This drawing confirms to BIS SP: 46-2003.
  - Bureau of Indian Standards (BIS) is our national standard.
  - All thick lines - 0.5 mm.
  - Chamfer at bottom of thread.
  - Rough mill the surface marked 'X'.
  - Punch roll number and part number.

Practice the following lettering exercises in A3/A4 paper as per the given ratio

1 Single stroke inclined letters of ratio 7:6, 7:5, 7:4, 7:3, 7:1 (Fig 1)

Fig 5



SINGLE STROKE INCLINED LETTERS

EDN16225



2 Single stroke vertical letters of ratio 7:6, 7:5, 7.4, 7:3, 7:1 (Fig 2)

Fig 6

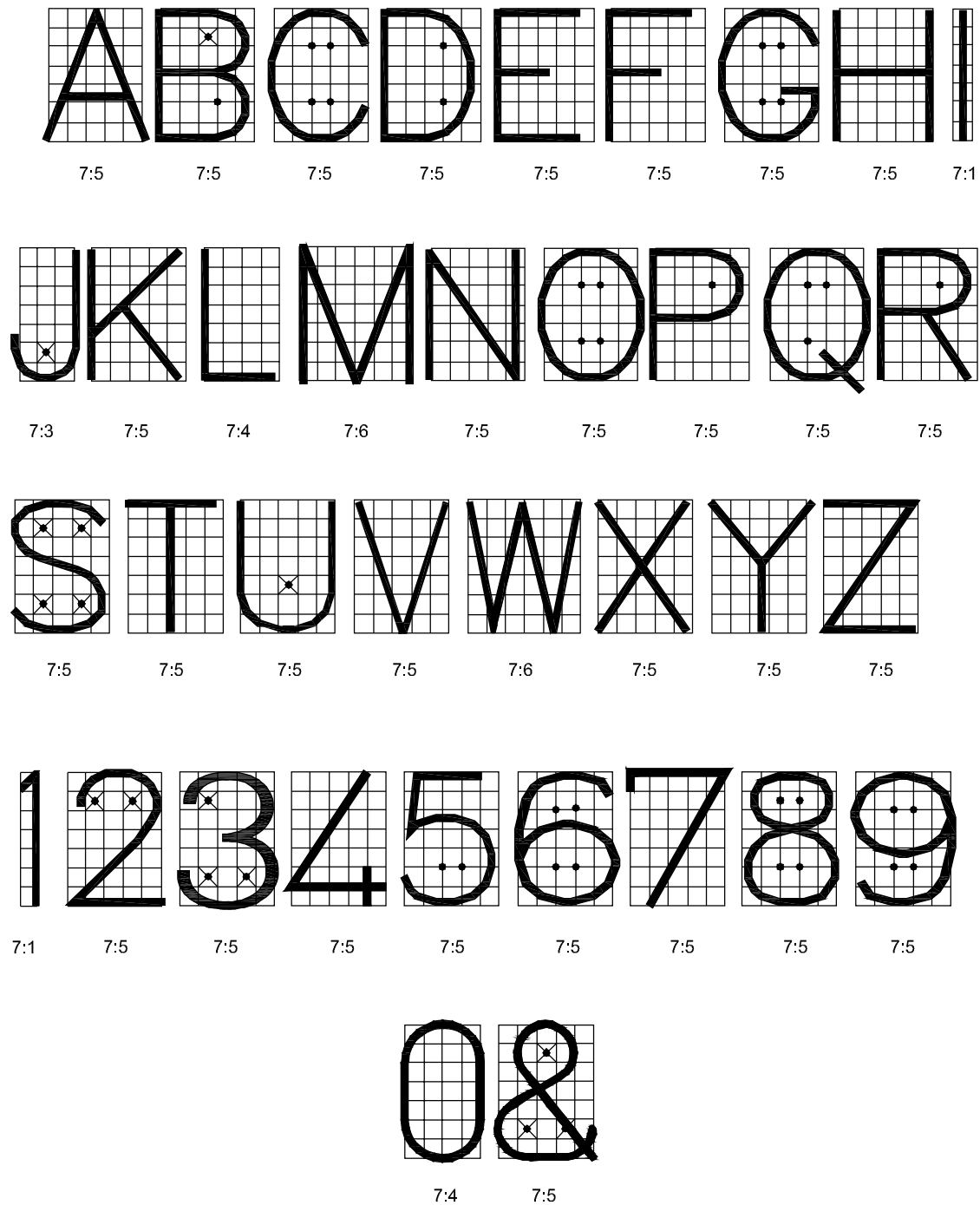

SINGLE STROKE VERTICAL LETTERS

EDN162226



3 Double stroke vertical letters of ratio 7:6, 7:5, 7.4, 7:3, 7:1 (Fig 3)

Fig 7

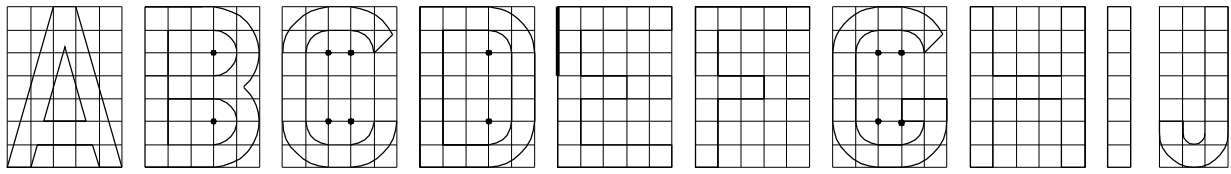

7:5    7:5    7:5    7:5    7:5    7:5    7:5    7:5    7:1    7:3

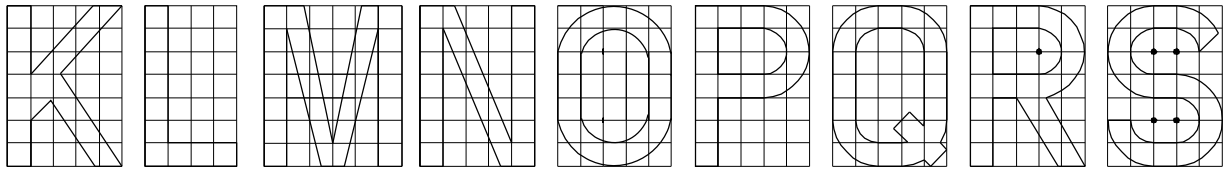

7:5    7:4    7:6    7:5    7:5    7:5    7:5    7:5    7:5

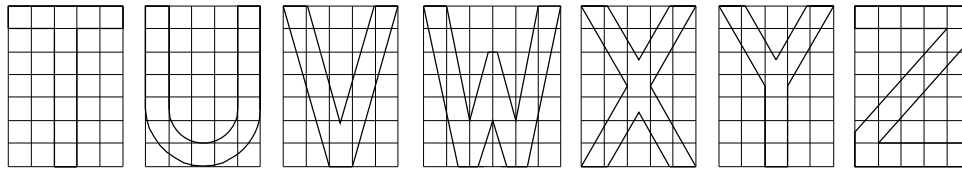

7:5    7:5    7:5    7:6    7:5    7:5    7:5

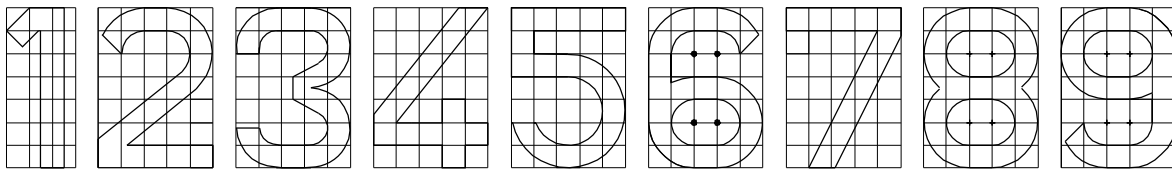

7:3    7:5    7:5    7:5    7:5    7:5    7:5    7:5    7:5

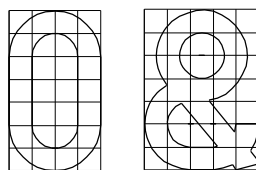

7:4    7:5

DOUBLE STROKE VERTICAL LETTERS

EDN162227

4 Double stroke inclined letters of ratio 7:6, 7:5, 7.4, 7:3, 7:1 (Fig 4)

Fig 8

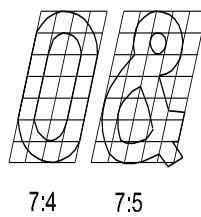
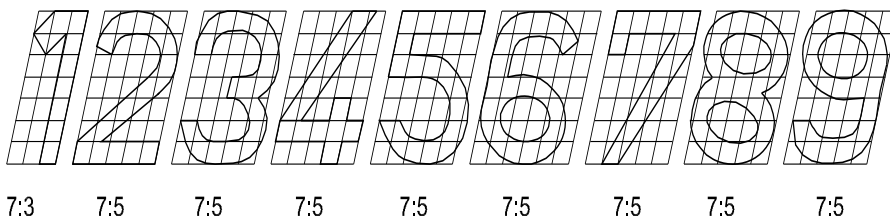
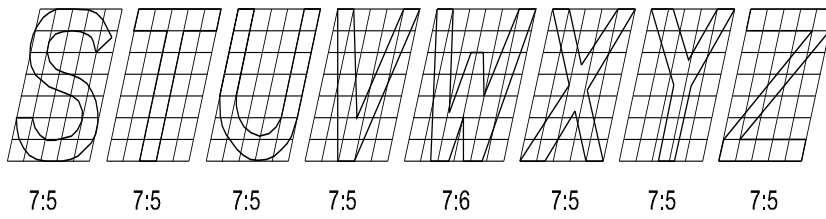
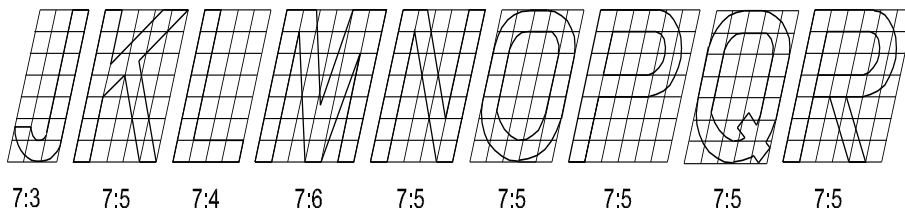
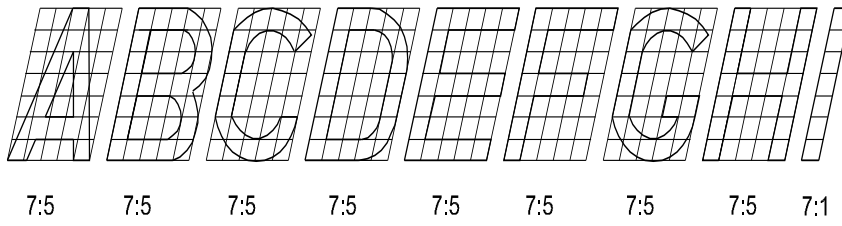

DOUBLE STROKE INCLINED LETTERS

EDN162228

**Dimensioning - Definition, and its types, types of arrow heads and leader line with text**

**Importance of dimensioning:** Any Component or product manufactured should be confirm to its specification. In fact, without specification of product, there cannot be production. In engineering industry, all manufacturing is controlled by the technical specification of product or components.

Technical specification provides complete information on the shape, size, tolerance, finish, material and other technical aspects such as heat treatment, surface coating and other relevant information required to manufacture a component. In most cases technical specifications of components are given in the form of a technical drawing while shape is described by various types of views i.e Orthographic, pictorial and perspective projection and size is given by dimensions.

**Definitions related to dimensioning**

**Dimension:** It is a numerical value expressed appropriate unit of measurement and indicated graphically on technical drawings with lines, symbols and notes.

**Dimensions are classified according to the following types:**

**Functional dimension (F):** It is a dimension which is essential to the function of the component or space. They are generally shown with limits. (Fig 1)

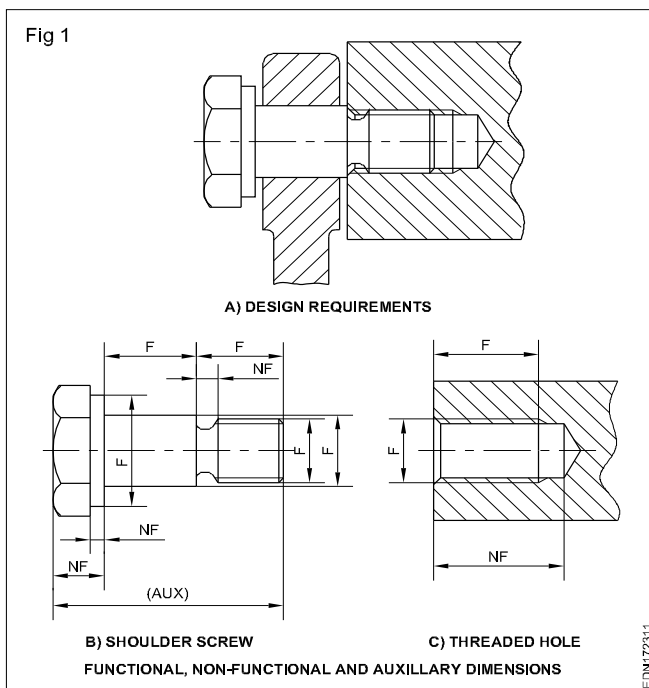

**Non-functional dimension (NF):** It is a dimension which is not essential for the function of the component or space.

**Auxiliary or Reference dimension (AUX/REF):** It is the dimension given for information only. It is derived from the values given on the drawing or related documents and it does not given in the production or inspection. (Fig 1)

**Size dimensions:** Give the size of a component, part, hole, slot, depth, width, radius etc.

eg: L1, L3, H, h1, S etc. (Fig 2)

**Location dimension:** Give or fixes the relationship of the features. viz centre of holes, slots and any significant forms. (Fig 2)

eg: L4, L5, L6

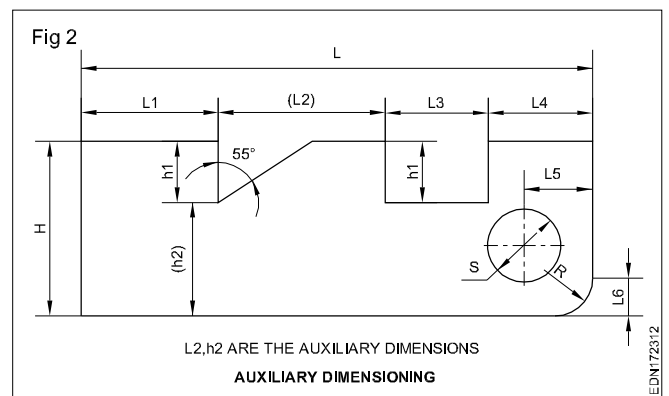

**Feature:** It is an individual characteristic such as flat surface, cylindrical surface, shoulder, screw thread, a slot, a curve or profile etc. (Fig 3 & 4)

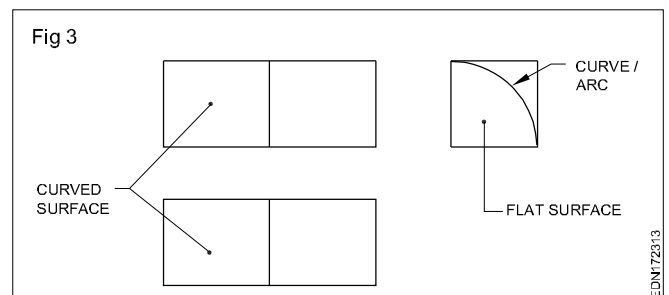

**End product:** It is a part ready for direct use or assembly or it can be a part ready for further process. e.g a casting, shoulder screw etc. (Fig 4)

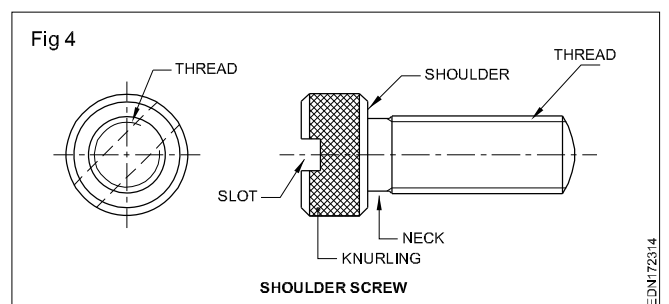

**The unit of measurement in general, unless or otherwise specified is mm (millimetres). On the dimensions of drawings the abbreviation mm is omitted and a general note is given in an appropriate corner as "All dimensions are in mm".**

## Elements of dimensioning

- Extension line - a
- Dimension line - b
- Leader line - c
- Termination of dimension line - d
- The original (starting point) indication and the dimension (a).

**Extension line:** It is a thin line projecting from the feature and extending beyond the dimension line. (Fig 5)

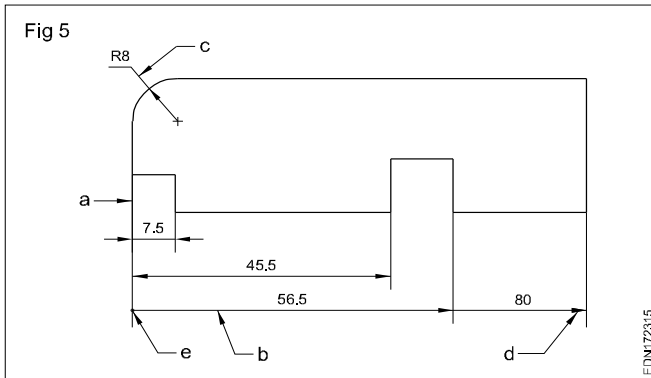

It is normally perpendicular to the feature being dimensioned, but may be drawn obliquely as shown for dimensioning tapers, parallel to each other. (Fig 5)

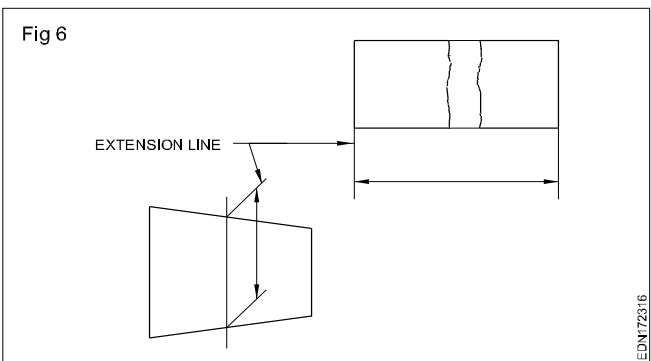

When construction lines are required to be shown for practical purposes of the intersecting projection lines extend beyond their point of intersection. (Fig 7)

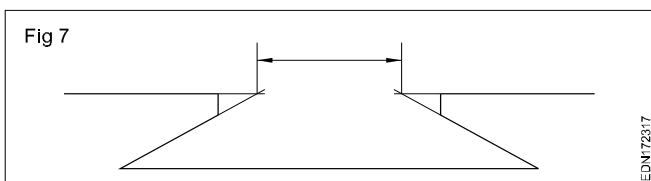

Extension lines (Projection lines) should not cross the dimension lines, but where not possible the lines should not break. (Fig 8)

**Dimension line:** These are thin continuous lines, terminated at ends by arrow heads, dots or oblique lines touching the extension line. (Fig 9)

Dimension line may cut or cross another dimension line where there is no other way.

Dimension to the hidden lines be avoided. (Fig 10)

Arrow heads may be placed outside where space is insufficient.

86

Engineering Drawing : (NSQF) Exercise 1.7.23

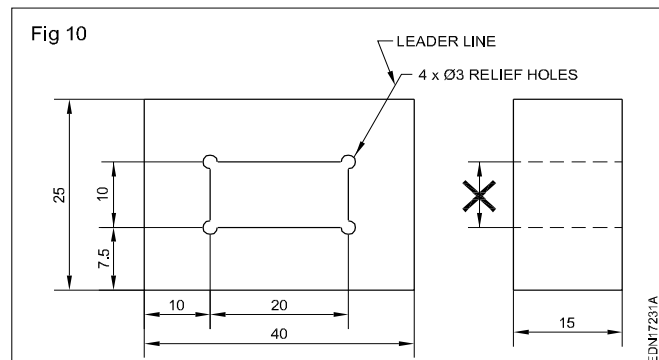
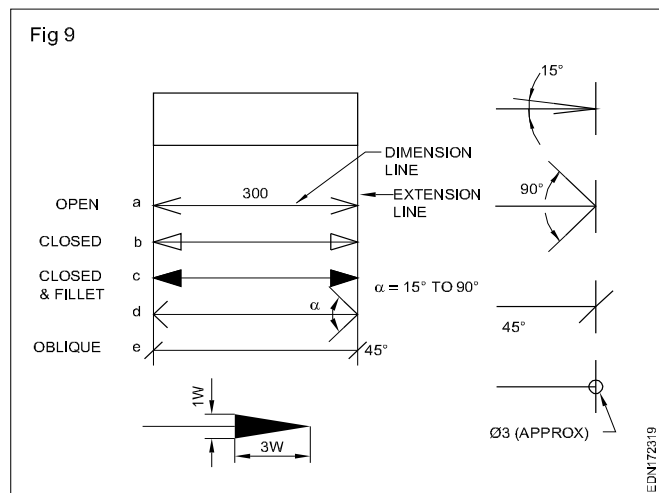
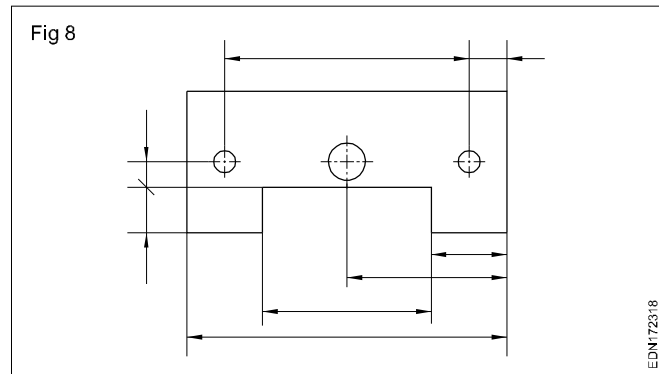

**Leader line:** It is a thin continuous line. It connects a note or dimension with the features to which it applies. (Fig 10)

**Termination and Origin indication:** The size of the terminations (arrow heads/oblique strokes) shall be proportional to the size of the drawing. Only one style of arrow head shall be used on a single drawing. However, where the space is too small for the arrow heads, it may be substituted by a dot or by an oblique line. Arrow heads are drawn as short lines forming barbs at any convenient included angle between 15° and 90°. They may be open, closed or closed and filled in. Oblique strokes drawn as short line inclined at 45°. (Fig 9)

**Indicating dimensional values on drawings:** All dimensional values shall be shown on drawings in characters of sufficient size to ensure complete legibility on the original drawings as well as on reproductions made from micro-filming.

They shall be placed in such a way that they are not crossed or separated by any other line on the drawing.

**Dimensioning and its practice - Methods of dimensions and position of dimensioning (aligned, unidirectional)**

**Methods of indicating values:** There are two methods used for indicating the values. Only one method should be used on any one drawing.

- Dimensioning by co-ordinates
- Combined dimensioning.

**Method 1**

Dimensional values shall be placed parallel to their dimension lines and preferably near the middle, above and clear of the dimension line. However, values shall be indicated so that they can be read from bottom or from the right-hand side of the drawing. Dimension lines are not broken. Dimensioning of angles also given in the same way. (Fig 1 & 2) This method is known as **aligned system** of dimensioning.

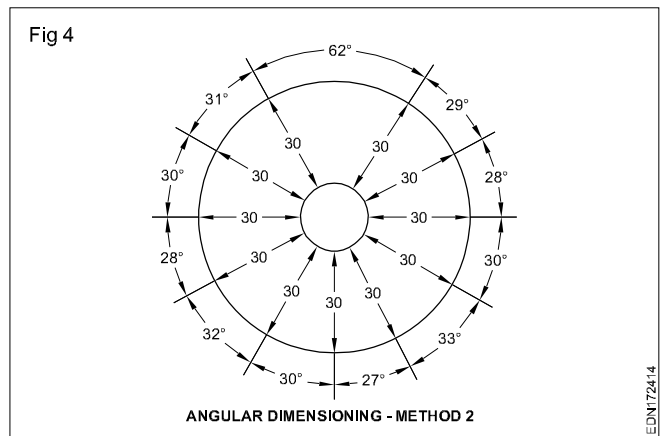
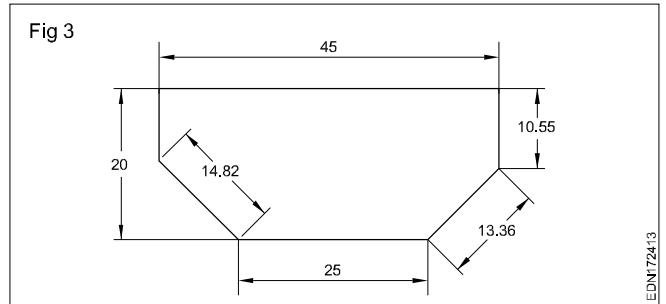
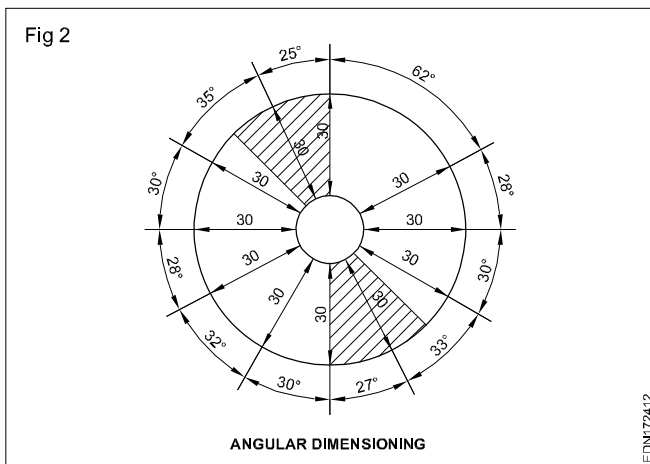
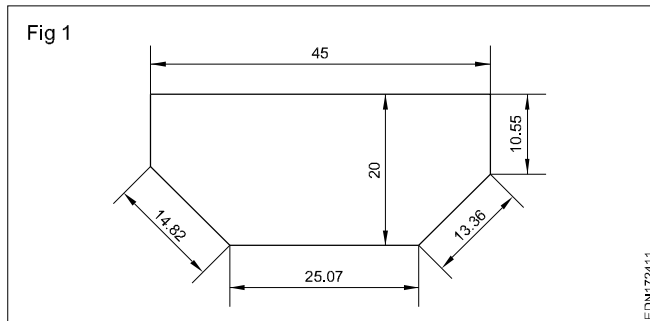

**Chain dimensioning:** It is used where the possible accumulation of tolerances does not infringe (effect) on the functional requirement of the component. (Fig 5)

**Method 2 Unidirectional system**

Dimensional values shall be indicated so that they can be read from the bottom of the drawing sheet. Non-horizontal dimension lines are interrupted, preferably near the middle so that the value can be inserted. (Fig 3&4). This method is termed as **unidirectional system** of dimensioning.

**Arrangement and indication of dimensions**

The arrangement of dimensioning on a drawing shall indicate clearly the design purpose.

The arrangements of dimensioning are:

- Chain dimensioning
- Dimensioning from a common feature

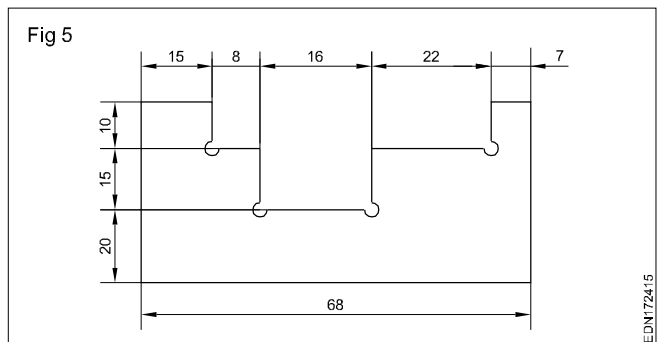

Dimensioning from a common feature is used where a number of dimensions of the same direction relate to a common origin.

Dimensioning from a common feature may be executed as parallel dimensioning or as superimposed running dimensioning.

**Parallel dimensioning:** Dimensions of features are taken from one datum/common origin and are shown parallel to other and placed, so that the dimensional values can easily be added in Fig 6.

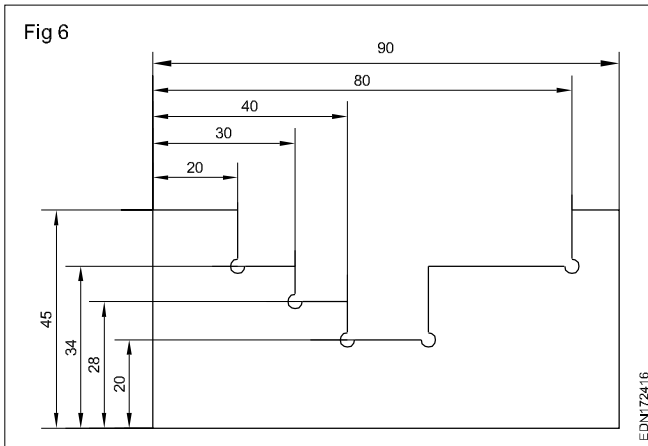

**Superimposed running dimensioning** (Progressive dimensioning): It is a simplified dimensioning also Cumulative error is controlled. It starts from one origin with arrow heads in one direction only. This may be used where there are space limitations and where no legibility problems would occur.

The origin indication is placed appropriately and the opposite ends of each dimension line shall be terminated only with an arrow head. It may be advantageous to use superimposed running dimensions in two directions. (Fig7)

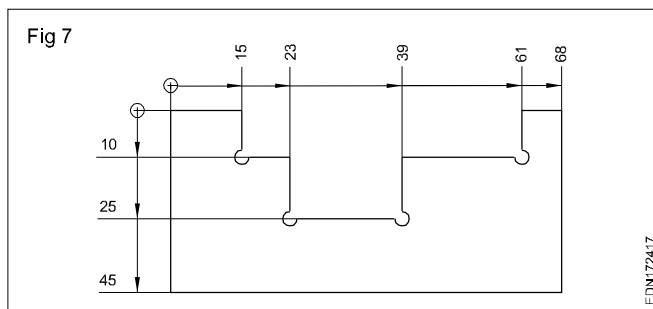

**Dimensioning by co-ordinates:** This system is much used for components, produced on jig boring machine. Two edges are taken as datum. (references)

Instead of dimensioning in superimposed way, same may be tabulated and given. (Fig 8)

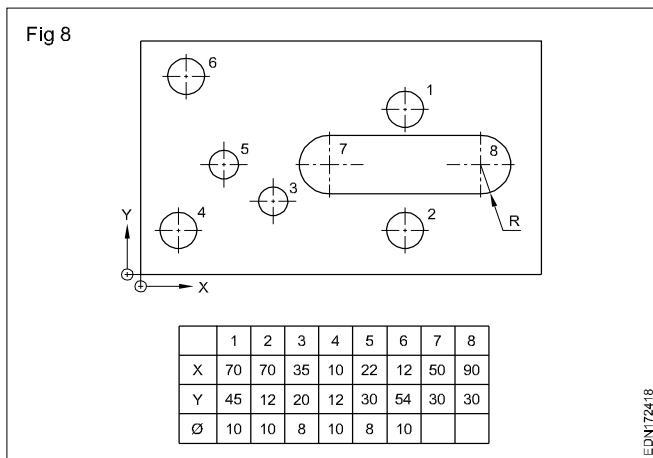

This method is useful in indicating places/positions in country, city and site plans.

**Combined dimensioning:** Dimensions are given in chain dimensioning and parallel dimensioning. Common feature is combined. (Fig 9)

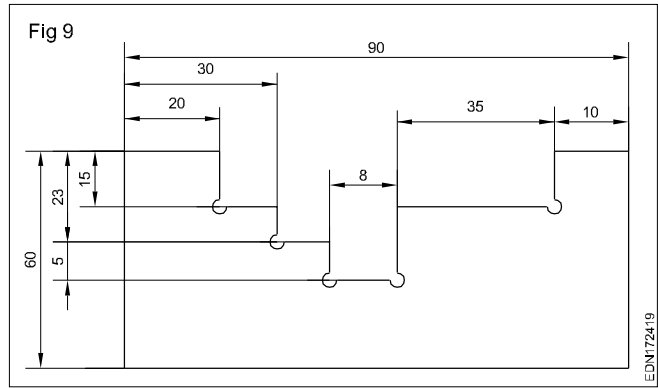

### Methods of dimensioning common features

**Dimensioning Tapered parts:** When dimensioning tapered part, extension lines be at an angle and parallel to each other. Dimension line be drawn parallel to the feature to be dimensioned. (Figs 10 & 11) They may sometimes be shown with large dia and or MT number.

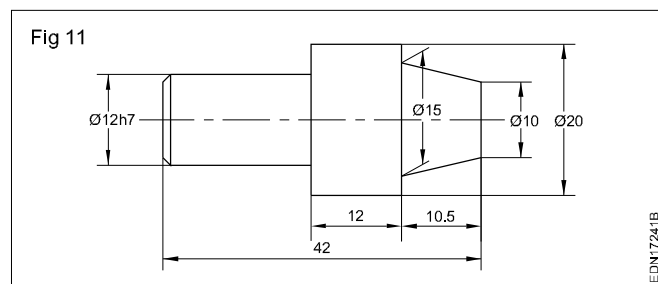
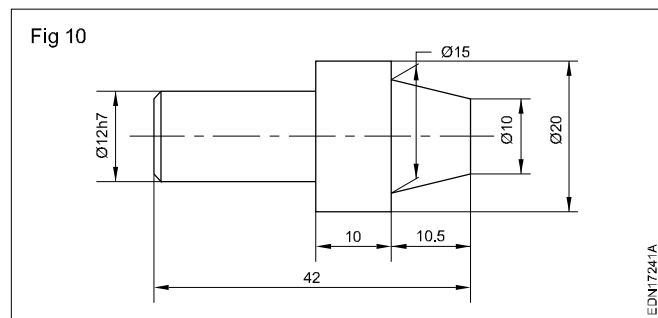

**Dimensioning smaller width:** Arrow heads are replaced by oblique lines. (Fig 12)

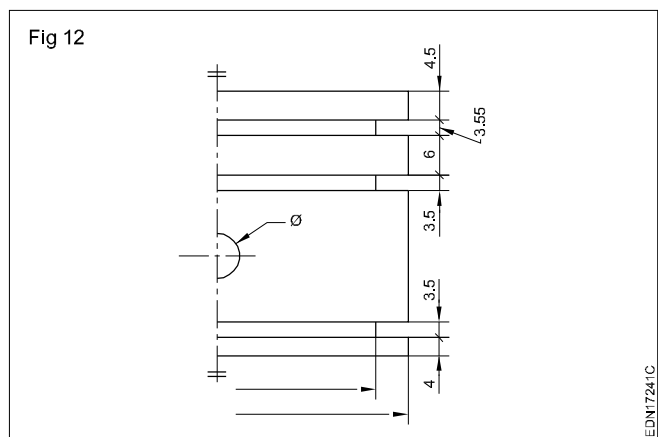

To avoid placing dimensions too far away from feature, dimension lines are drawn closer and not fully. (Fig 13)

**Dimensioning cylindrical and spherical features:** Cylindrical features have diameter and length whereas sphere has a diameter only.

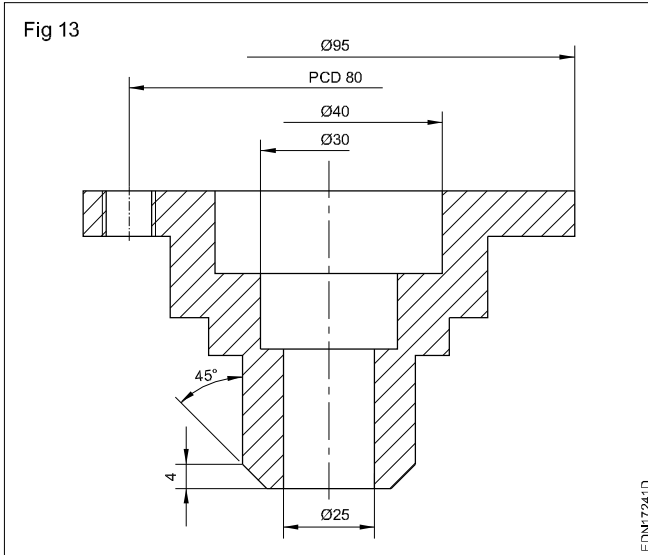

Diameter may be indicated by any one of the abbreviation D, Dia, d, dia or  $\phi$  and radius may be indicated by R, r, Rad or rad by square. Any one abbreviation or symbol on a drawing may be indicated by SQ or  $\square$ .

The length if any required to give along with dia, if it is shown as  $\phi$ ...x... long. (Fig 14)

- $\phi$  - Diameter
- R - Radius
- $\square$  - Square
- SR - Spherical radius
- S $\phi$  - Spherical diameter

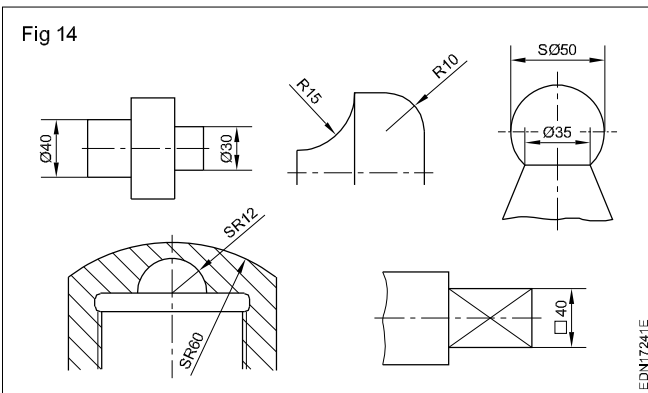

**Dimensioning a chord:** For dimensioning of chord, refer Fig 15. It is shown as linear size.

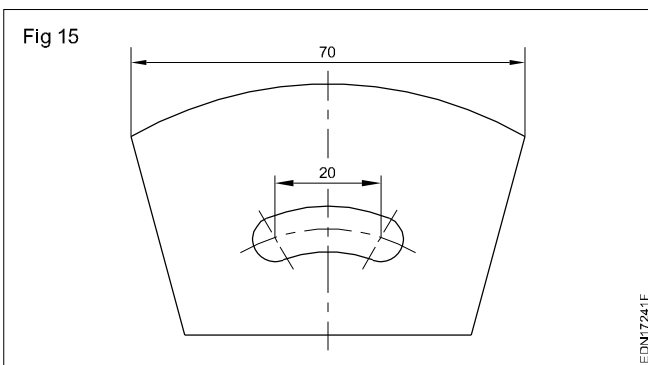

**Dimensioning an arc/radius:** A small arc is shown over the dimension value, while dimensioning an arc. (Fig 16)

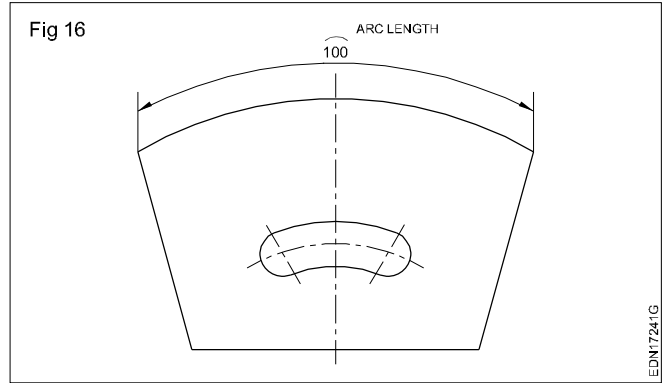

**Dimensioning equidistant features:** Where equidistant features or uniformly arranged elements are parts of the drawing, specification of the dimensioning may be simplified. Linear spacings may be dimensioned as in Fig 17a&b.

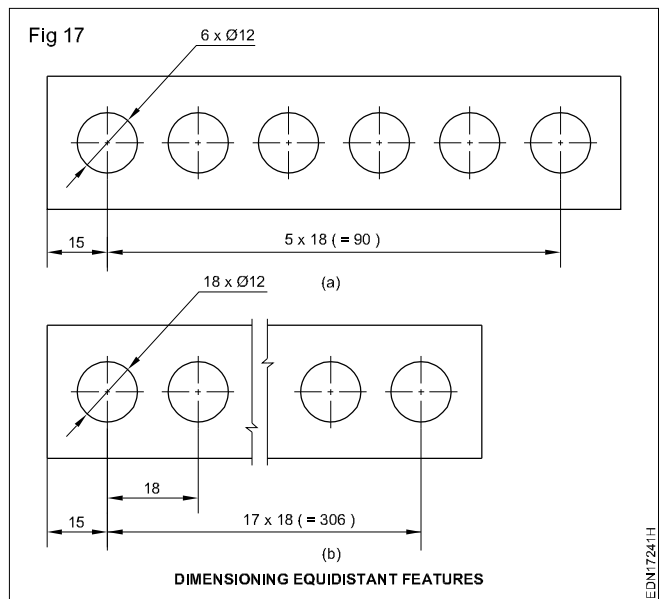

**Dimensioning angles and Angular spacings**

Equal angles eg.  $4 \times 10^\circ = 40^\circ$   
 Equal centre distances eg.  $4 \times 10 = 40$ . (Fig 18)

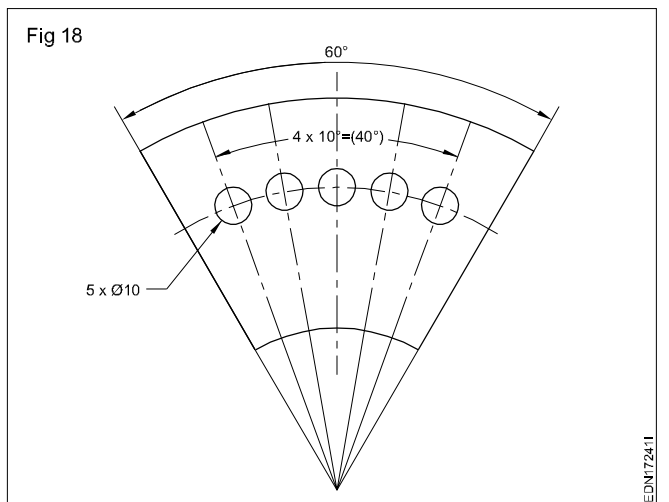

When the drawing is clear, symbols or abbreviation viz. dia, Pcd and angle can be omitted. (Fig 19)

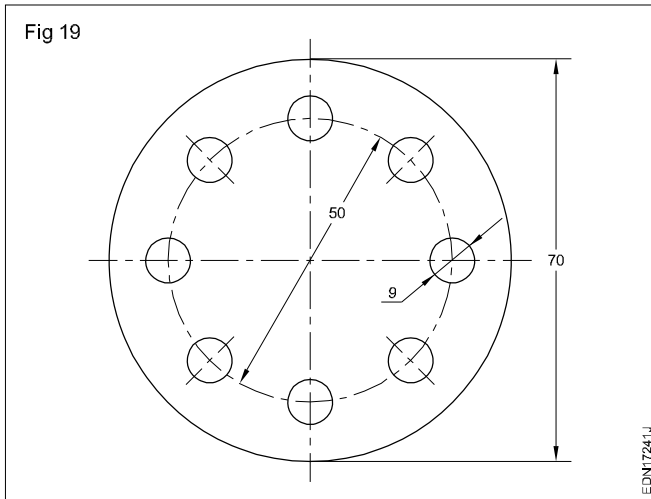

**Dimensioning periphery:** The features on the periphery can be shown as given in the figure, indicating width, depth and number of slots. (Fig 20)

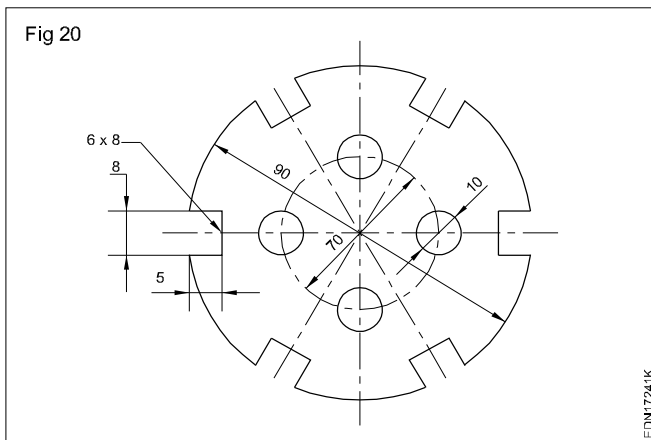

**Dimensioning repeated features:** When elements of same size occur, but not of same pitch be shown as in Fig21.

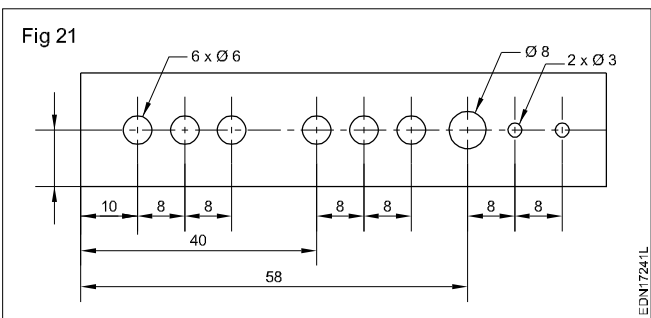

**Countersinks and counterbore (IS:10968-1984):** For simplification, the holes are indicated by centre lines and marked by different letters to different type/size of hole. The holes may be plain, through blind, tapped, countersink of counterbore. (Fig 22)

**Dimensioning chamfers and undercuts:** Chamfer of 45° may be shown by leader line indicating chamfer width and angle or by dimension line with chamfer width and angle. (Figs 23 & 24)

**Dimensioning undercut:** Dimensioning undercuts are dimensioned either by normal dimensioning the width i.e u/c 4 x 2 or by leader terminating horizontally u/c 4 x 2. (Fig23)

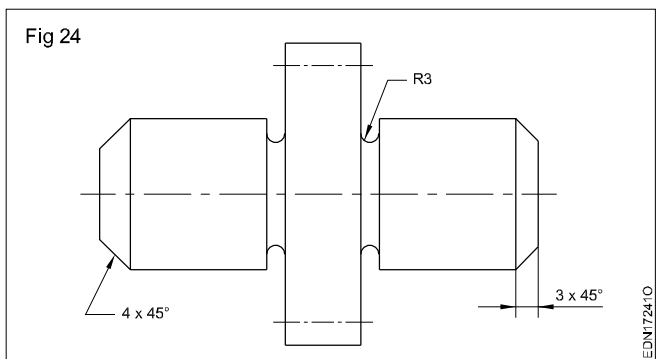
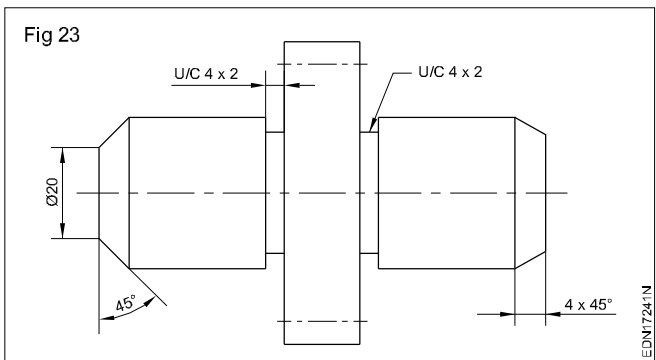
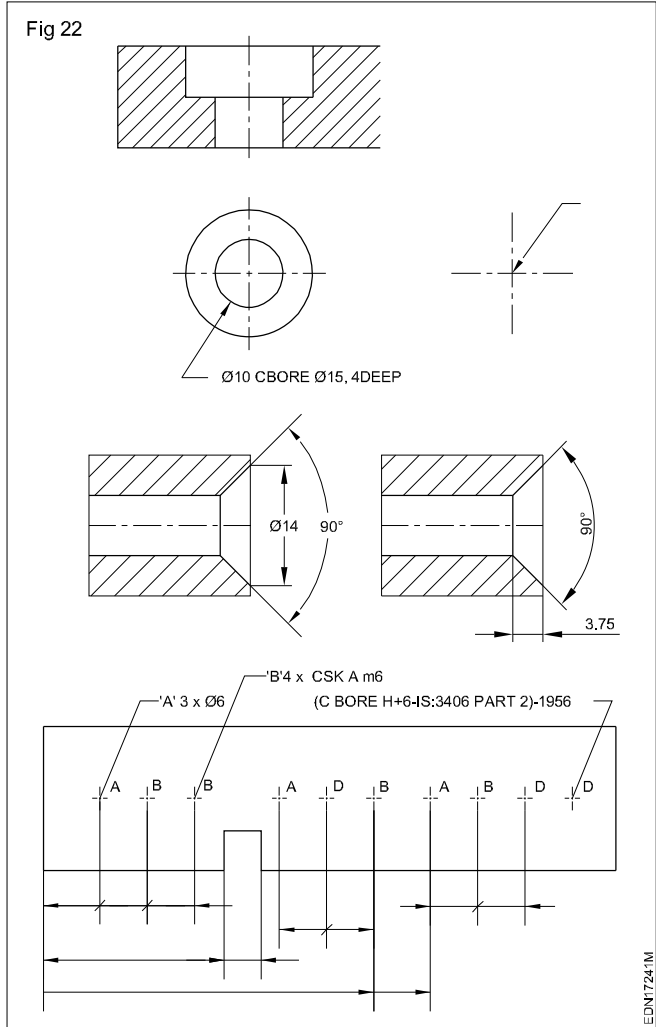



**Other indications:** In order to avoid repeating the same dimensional values or to avoid long leader lines, reference letters/numbers may be used in connection with an explanatory table or note. In such cases leader lines may be omitted. (Fig 25)

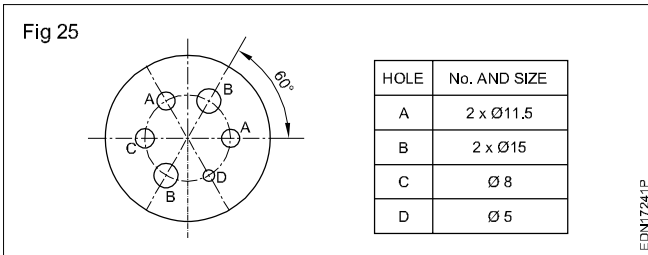

In partially drawn views and partial sections of symmetrical parts the dimension lines that need not cross the axis of the symmetry are shown extended slightly beyond the axis of symmetry. The second termination is then omitted. (Fig 26)

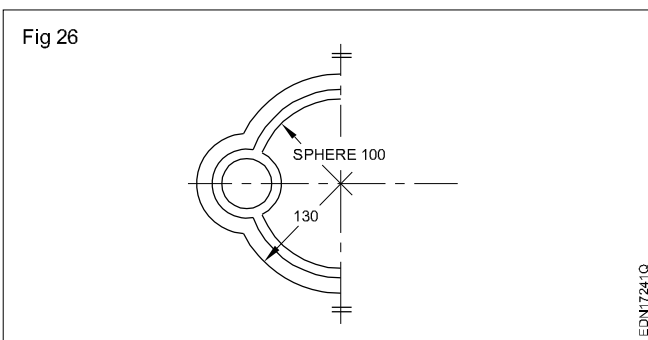

Where several parts are drawn and dimensioned in an assembly, the groups of dimensions related to each parts should be kept as separate as possible. (Fig 27)

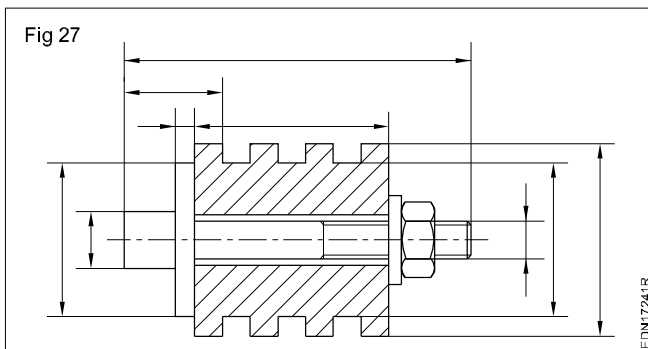

**Dimensioning arcs by radius:** Only one arrow head termination, with its point on the arc end of the dimension line shall be used where a radius is dimensioned. The arrow head may be either inside or outside of the feature outline. (Fig 28)

**Values for dimensions out of scale:** After finalising sizes may require modification. Instead of re-drawing the entire component, the dimension which is changed is marked and a thick line drawn below such size indicating this (feature) size is not to scale (NTS). (Fig 29)

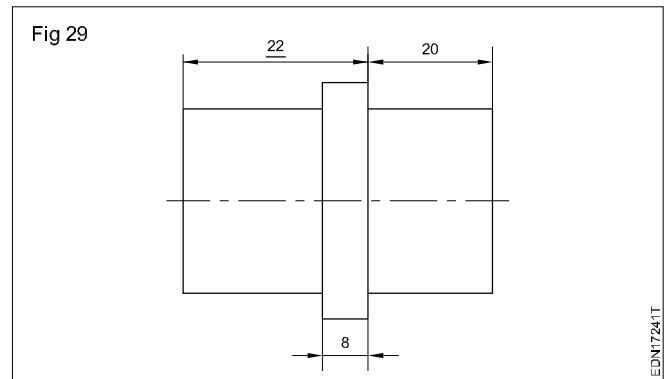
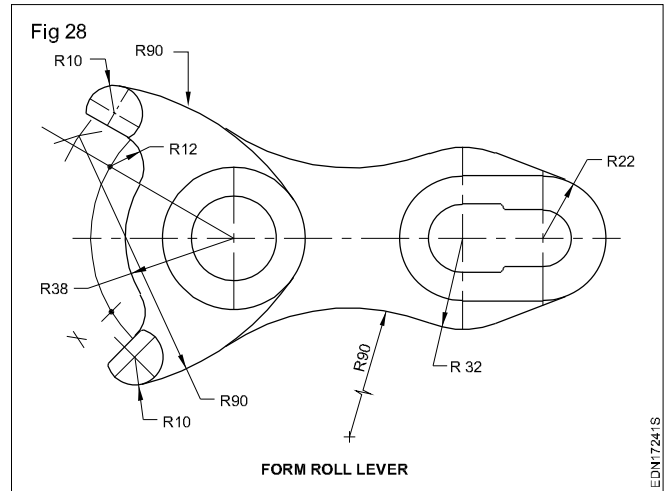

**Principles and application of dimensioning:** Before proceeding to give dimensions, consider the following steps:

- Mentally visualize the object and divide it into geometrical shapes such as prisms, cones, cylinders, pyramids etc.
- Place the size dimension on each form.
- Consider the relationship of mating parts and the process of production, then select the locating (reference or datum) centre lines and surfaces.
- ensure that each geometrical form is located from a centre line and/or a finished surface.
- Place the overall dimensions.
- Add the necessary notes like surface finish, specific operations, material, fit, type of thread etc. (Fig 30)
- All dimensional information necessary to define a part or component clearly and completely shall be shown directly on a drawing unless this information is specified in relevant documents.
- Each feature shall be dimensioned once only on a drawing.
- Dimension shall be placed on the view or section that most clearly shows the features.

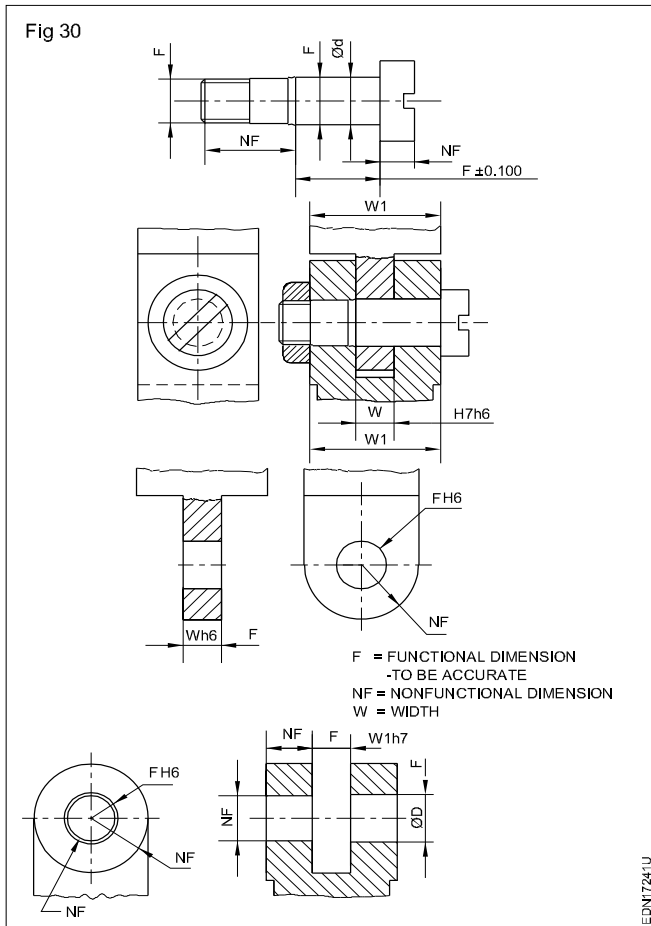

Each drawing shall use the same unit (for example, millimetres) for all dimensions but without showing the unit symbol. In order to avoid misinterpretation, the pre-dominant unit symbol on a drawing may be specified in a note.

Where other units have to be shown as part of the drawing specification ( for example, N, m for torque or kPa for pressure), the appropriate unit symbol shall be shown with the value.

No more dimensions than are necessary to define a part or an end product shall be shown on a drawing. No feature of a part or an end product shall be defined by more than one dimension in any one direction. Exception may, however be made

- where it is necessary to give additional dimensions at intermediate stages of production (for example, the size of a feature prior to carburizing and finishing).
- where the addition of an auxiliary dimension would be advantageous.

Production processes or inspection methods should not be specified unless they are essential to ensure satisfactory functioning or interchangeability.

Functional dimensions should be shown directly on the drawing wherever possible. (Fig 31)

Occasionally indirect functional dimensioning is justified or necessary. In such cases, care shall be exercised so that the effect of directly shown functional dimensioning is maintained. (Fig 32) shows the effect of acceptable indirect functional dimensioning that maintains the dimensional requirements established by (Fig 31) .

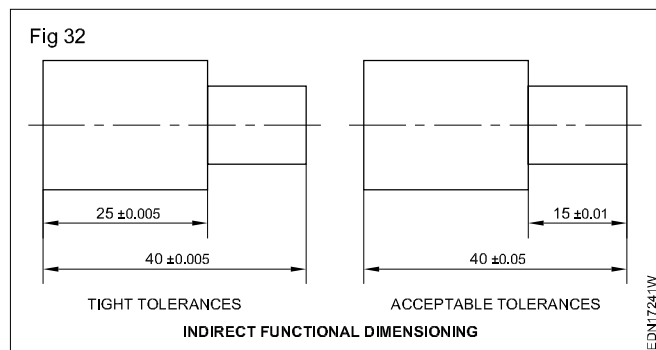
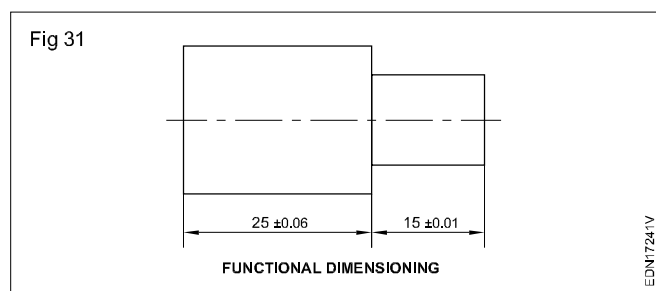

The non-functional dimensions should be placed in a way which is most convenient for production and inspection.

Projection lines should be drawn perpendicular to the feature being dimensioned. Where necessary, however, they may be drawn obliquely, but parallel to each other. (Fig 33)

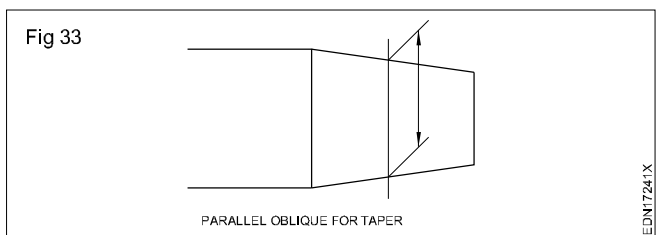

Dimension line shall be shown unbroken where feature to which it refers is shown broken, except in Method 2 (Unidirectional). (Fig 34)

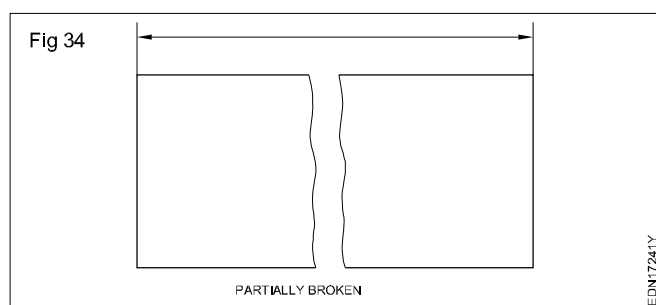

Avoid intersection of projection lines and dimension lines, where unavoidable neither line shall be shown with a break. (Fig 35)

A centre line or the outline of a part shall not be used as a dimension line but may be used in place of a projection line.

Any one style of arrow head termination shall be used on a single drawing. However, where space is too small for arrow head, oblique stroke or dot may be substituted. (Fig 36)

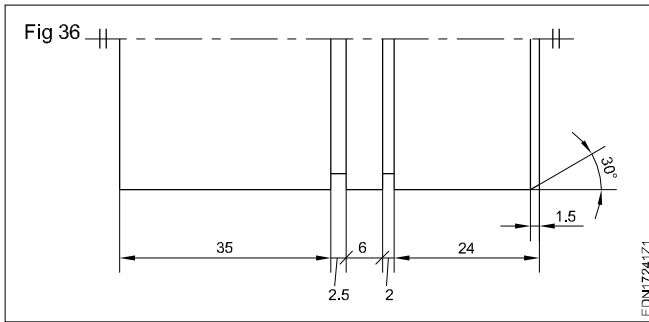
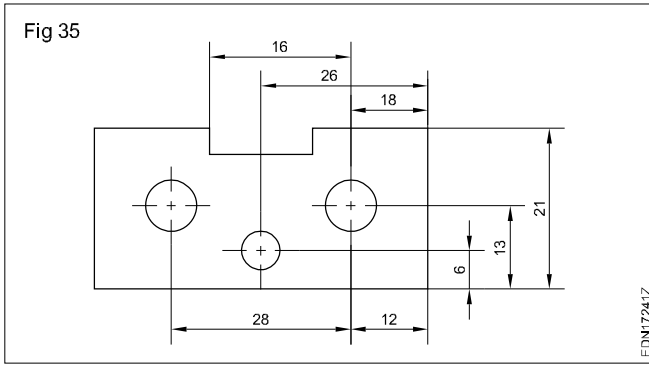

Arrow head terminations shall be shown within the limits of the dimension line where space is available. Where space is limited, the arrow head termination may be shown outside the intended limits of the dimension line that is extended for that purpose. (Fig 37)



Only one arrow head termination, with its point on the arc end of the dimension line, shall be used where a radius is dimensioned. The arrow head termination may be either on the inside or on the outside of the feature outline for its projection line depending upon the size of the feature. (Fig 38)

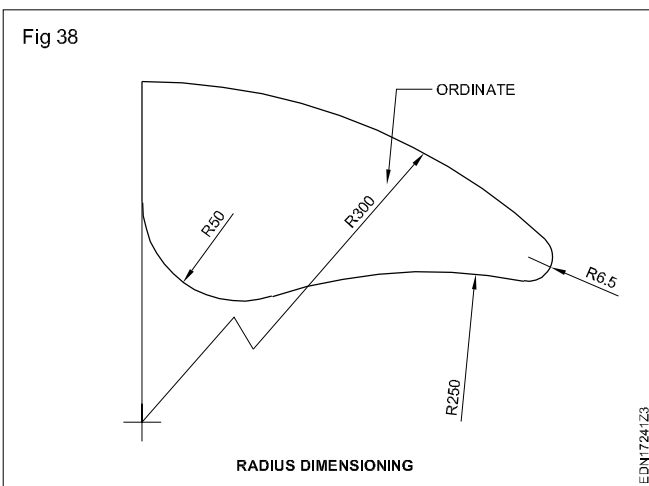

Dimensional value should be legible.

Dimension of spherical features should be preceded by S or SR.

Values for dimensions out of scale, except where break lines are used shall be underlined with a straight thick line.

Use chain dimensioning where the possible accumulation of tolerances does not infringe effect on the functional requirements of the part.

Single dimension, chain dimensioning and dimension line from a common feature may be combined on a drawing if necessary.

Where the size of the radius can be derived from other dimensions, it shall be indicated with a radius arrow and the symbol 'R' without an indication of the value. (Fig 39)

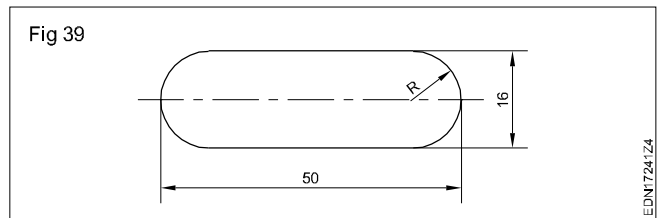

It may be advantageous to use superimposed running dimensioning in two directions. In such a case, the origins may be as shown in Fig 40.

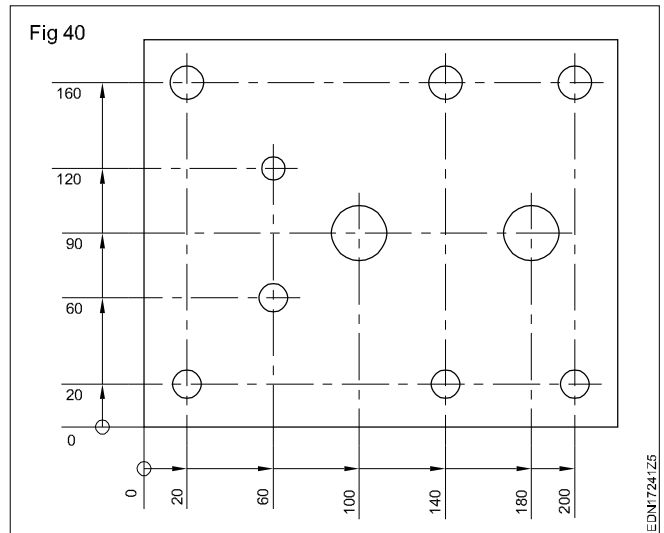

If it is possible to define a quantity of elements of the same size so as to avoid repeating the same dimensional value, they may be given as shown in Figs 41 & 42.

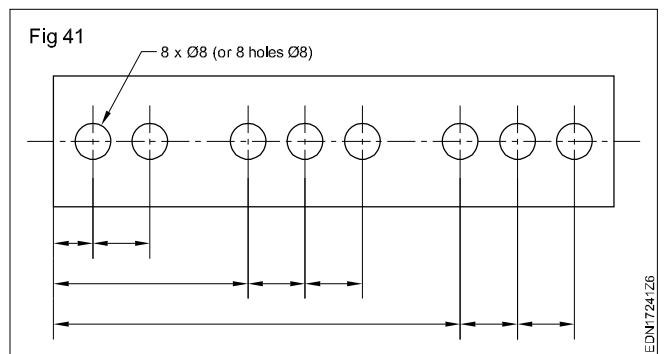

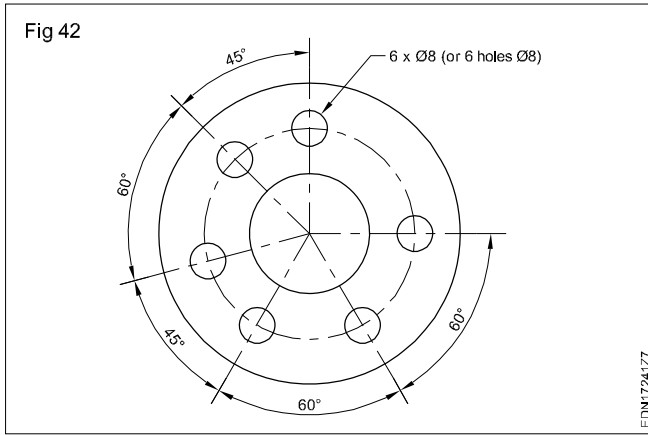

Where necessary, in order to avoid repeating the same dimensional value or to avoid long leader lines, reference letters may be used in connection with an explanatory table or note. Leader lines may be omitted. (Fig 43)

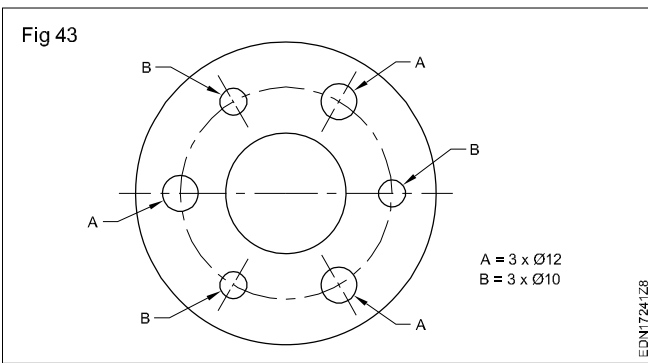

In partially drawn views and partial sections of symmetrical parts, the dimension lines that need to cross the axis of symmetry are shown extended slightly beyond the axis of symmetry. The second termination is then omitted. (Fig44)

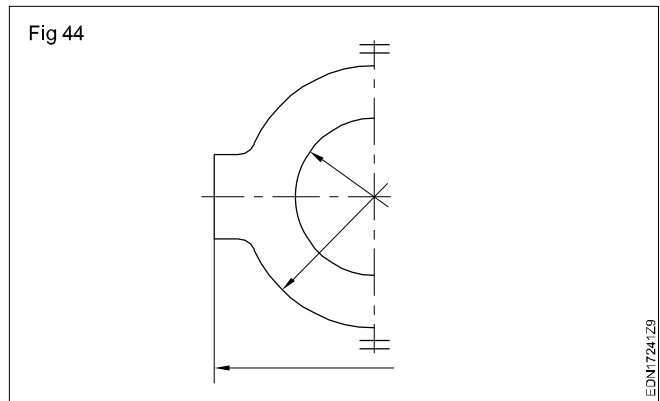

If the special requirement is applied to an element or revolution, the indication shall be shown on one side only. (Fig 45)

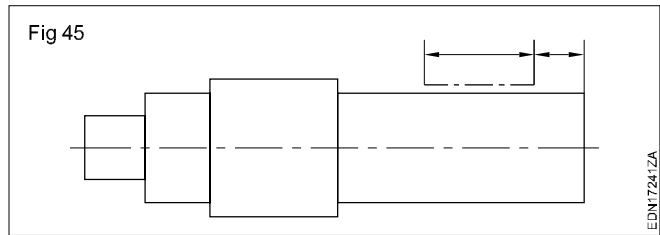

Where the location and extent of the special requirement requires identification, the appropriate dimensioning is necessary. However, where the drawing clearly shows the extent of the indication, dimensioning is not necessary. (Fig 46)

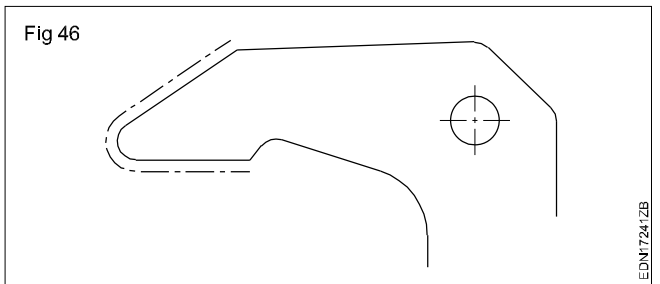

## Practice of dimensioning

1 Draw the two sheet metal templates to full scale with appropriate lines use 0.5 range line thickness. (Fig 1)

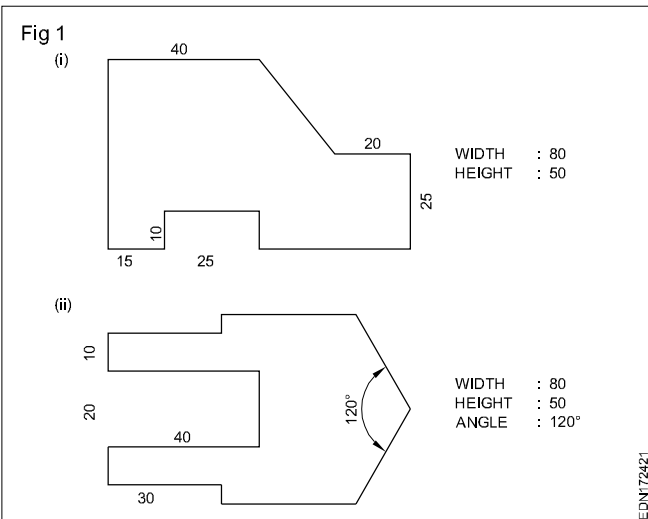

- Draw a rectangular block of length 80 mm and width 50 mm in thin lines.
  - Incorporate the features of the template as per the given dimension.
  - Draw by thick lines all visible out lines.
  - Give dimensions and maintain the line thickness as per the line range (0.5).
  - Complete the figure and remove the unwanted lines.
- 2 Draw the figures given. Maintain the types of lines as per the B.I.S and choose correct line thickness. (Fig2)
- According to the given dimensions, draw the figures given in Fig 2.
  - Select the appropriate lines and maintain uniformity.
  - Remove (erase) unwanted lines, arcs and complete the drawing.

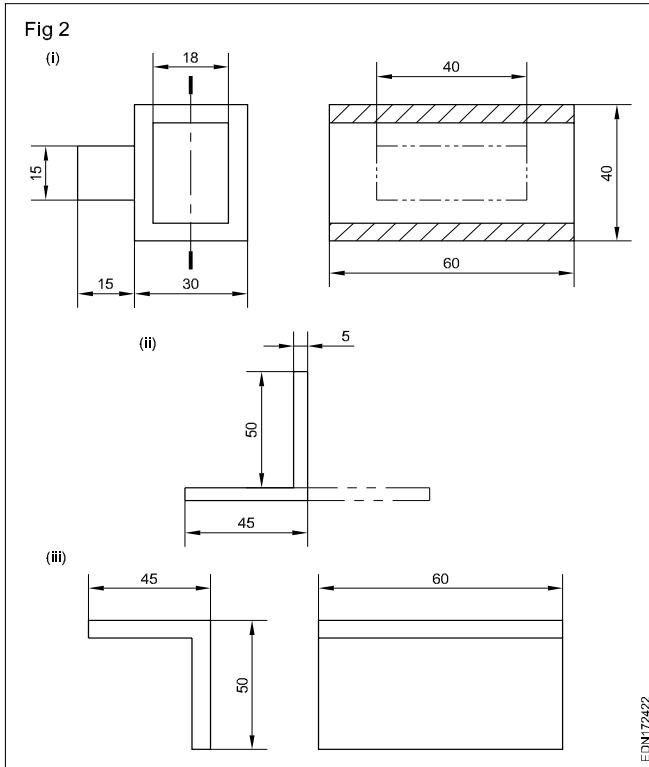

3 To the given drawing of the profile sheet metal as shown in Fig 3, place the dimensions in the aligned system. (Fig3a)

- Draw the drawing of the sheet metal to 1:1 scale.
- Draw the extension lines in continuation of outlines.
- Draw the dimension lines. (Fig 3b)

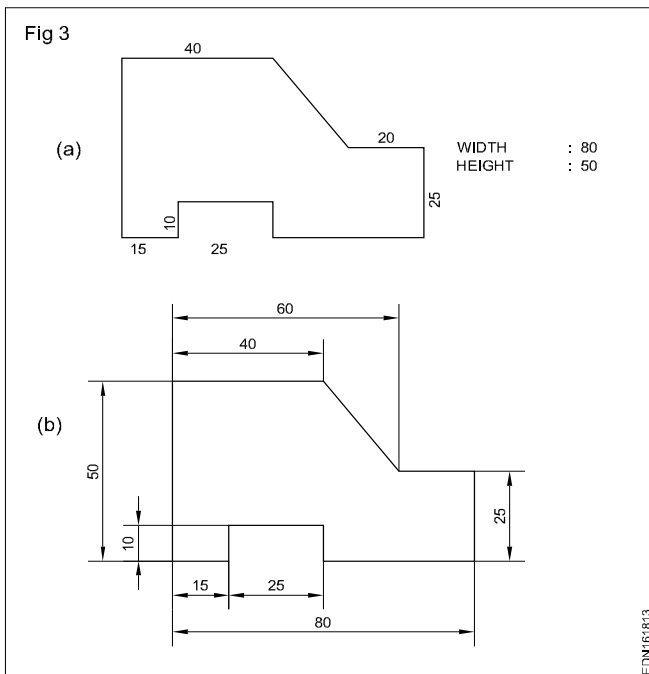

- Place the dimension value near the middle and above the dimension line to be read from "bottom and right hand side" of the drawing.

**Note: Draw the dimension line terminations as per IS:11669-1986.**

- Draw the arrow heads with short lines forming borbs at any convenient angle between 15° to 90°.

4 To the given drawing of the profiled sheet metal as shown in Fig 4a, give the dimensions in the unidirectional system.

- Place the horizontal dimensions above and middle of the dimension line without break.
- Break the dimension in the middle of all non-horizontal dimension lines. (Fig 4b)

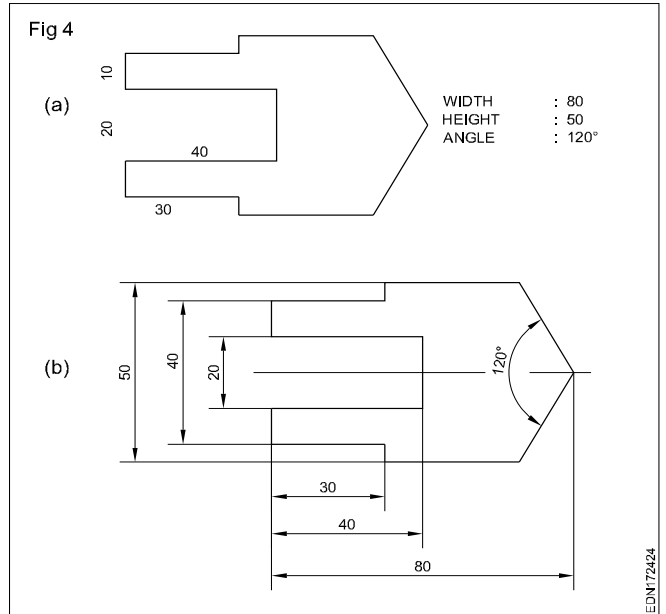

5 Motor cycle engine gasket is shown in figure 5. There are some mistakes in dimensioning. Reproduce the same in A3/A4 sheet provided and correct the mistakes according to the aligned system of dimensioning. (Fig 5)

6 Draw the given cover plate and give the dimensions in the aligned system. (Fig 6)

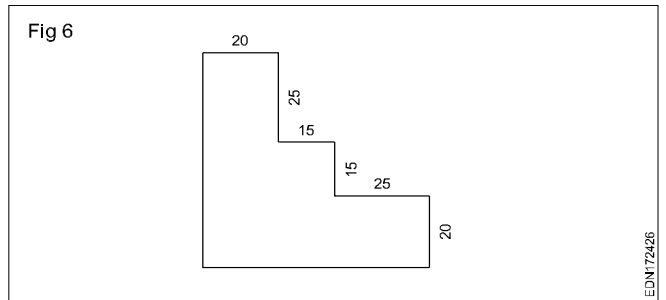

7 Draw the cover plate given in figure and place the dimensions in the unidirectional system. (Fig 7)

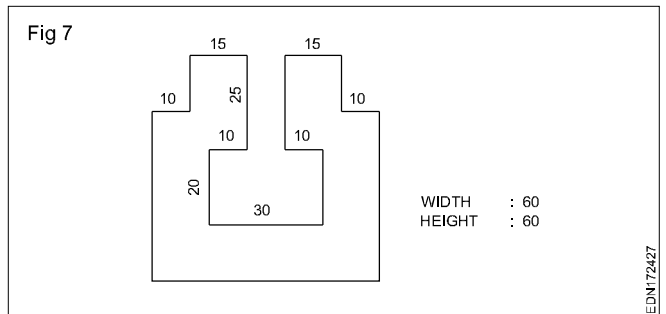

8 Draw the profiled plate given in figure having angular edge and give dimensions in aligned system. The left and bottom edge represent the dimension reference line. (Fig 8)

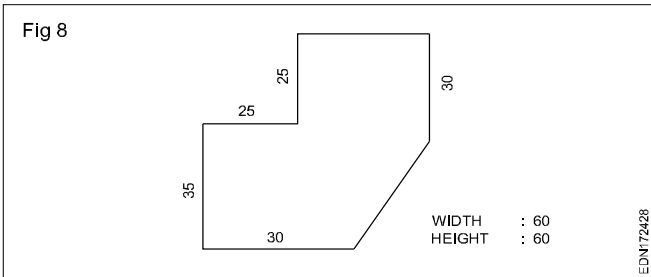
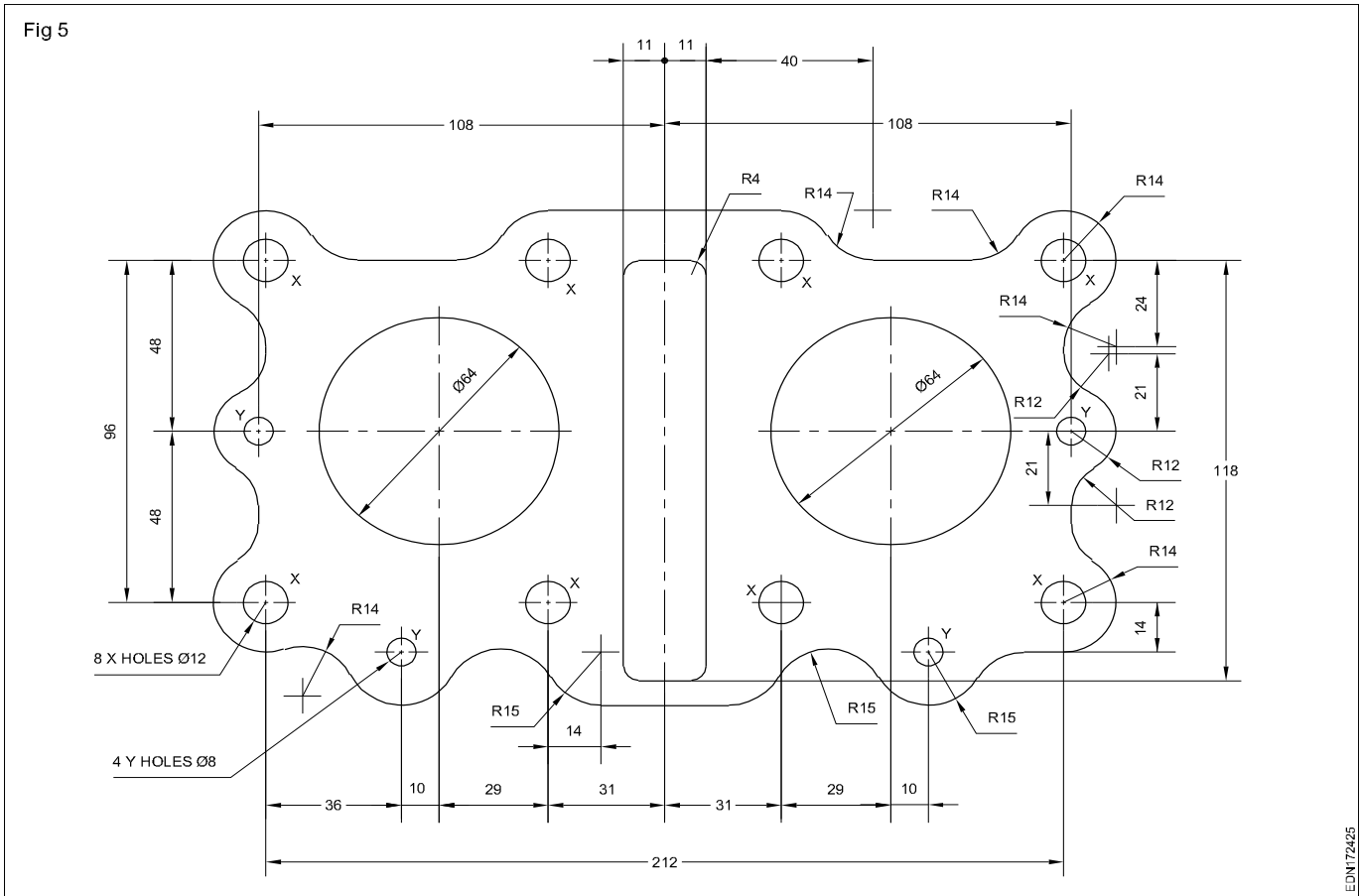

9 Draw the profiled plate sheet metal with angular edges and dimension in unidirectional system (Fig 9).

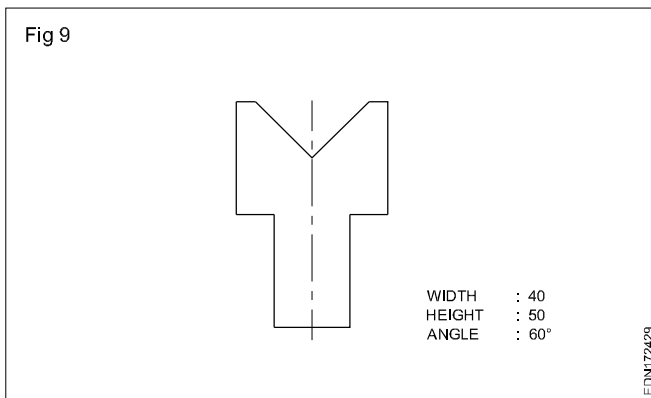

10 Draw the given distance plate and dimension in aligned system. The basic dimension of the plate is 60 mm x 80 mm (Fig 10).

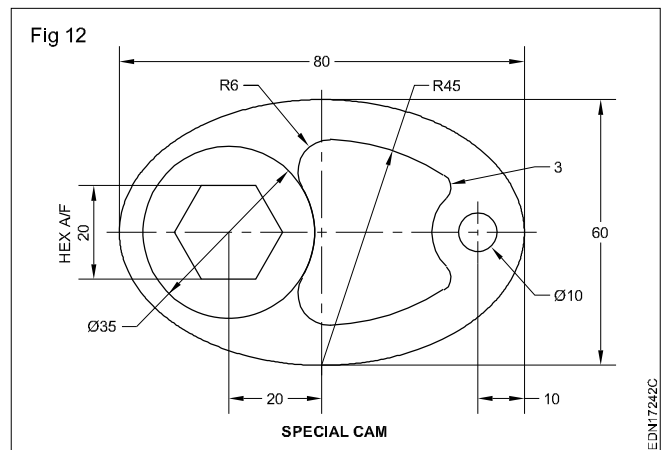
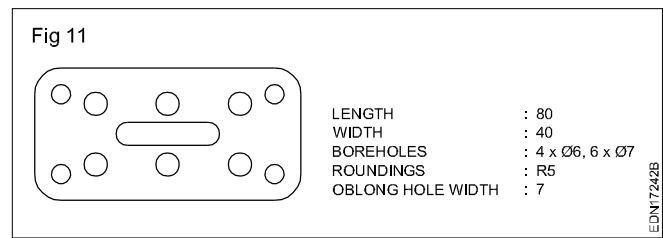
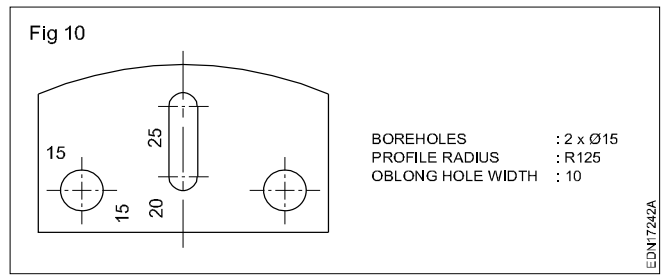

11 Draw the board of 3-phase motor given and dimension in aligned system (Fig 11).

12 Draw the special cam shown in figure and dimension according to aligned system (Fig 12).

Symbols preceding the value of dimension and dimensional tolerance

Combination of hole and shaft for a particular fit

Introduction

The limit system may be, according to the 'Basic hole' or 'Basic shaft' system. All the **internal** features are to be referred to as **hole** and the **external** features as **shaft**.

Basic hole system (Fig 1)

The basic hole system is the one in which the different clearances or interferences are obtained in association with various shafts with a single hole, whose lower deviation is zero i.e. the basic size of the hole is taken as standard and the diameter of the shaft is varied to get the desired fit.

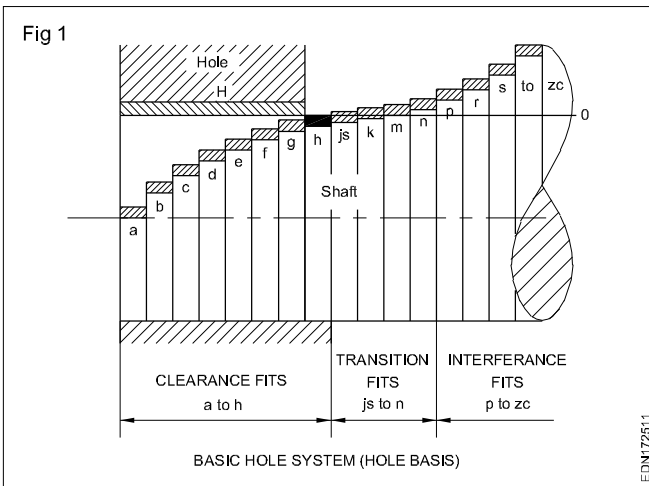

Basic shaft system (Fig 2)

The basic shaft system is one in which the different clearances and interferences are obtained in association of various holes with a single shaft whose upper deviation is zero i.e. the basic size of the shaft is the maximum size of the shaft. In the basic shaft system, the shaft is taken as standard and the diameter of the hole is varied to get the desired fit.

Fit	Shaft	Hole
Clearance	h	A up to H
Transition	h	J up to N
Interference	h	P up to Zc

**Basic hole or basic shaft systems** : Both the systems are equally valid. In general, most of the manufacturers of machine tools prefer the basic hole system because it is more economical. The reason is that holes are usually produced in batches in mass production by fixed diameter tools like twist drill, reamers, taps, broaches etc. Due to this, the machines need not be set up to obtain the proper size of the hole; setting up operations of jobs with respect to cutting tool consequently can be made quicker and cheaper.

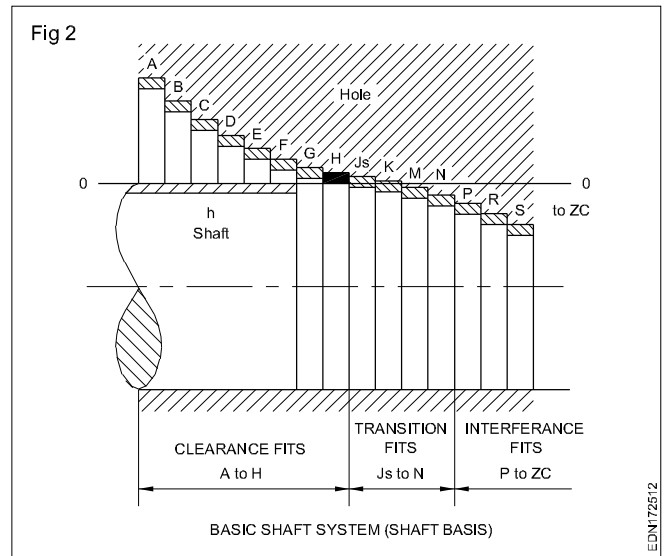

**Example (Fig 3):** In the basic shaft system all the holes are within the tolerance zone H7. The shafts receive the tolerance necessary for achieving the desired fit on the diameter to fix couplings, bearings, worm-gear etc.

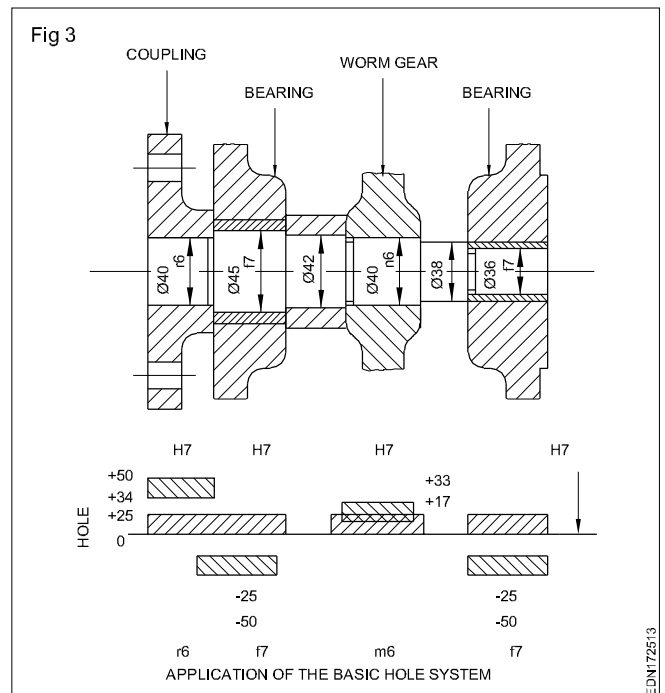

There are many cases in which the basic shaft system is more advantageous. This can be efficiently applied for long shafts machined to the same size over their full length. (Smooth drawn shaft, shafts ground in centreless grinding machines etc.) If the shaft is to mate with atleast two parts having holes that require different types of fit, the basic shaft system is preferred.



**Example**(Fig 4): A finished shaft with h6 tolerance is used and the holes of crank, bearing, gear, coupling are so tolerance that the desired fit is achieved.

Guide lines for the selection of fits are given in table - 1

TABLE 1

Number of combinations for different fits

Fits	Shaft	Holes			Classification	
		H6	H7	H8		
Clearance	c	-	-	c9	Slack running fit.	
	d	-	d8	d8/d10	Loose running fit.	
	e	e7	e8	e8/e9	Easy running fit.	
	f	f6	f7	f8	Running (normal) fit.	
	g	g5	g6	-	Close running fit.	
	h	h5	h6	h7/h8	Slide	
	Transition	j	j5	j6	j7	Push.
		k	k5	k6	k7	Easy keying.
m		m5	m6	-	Tight keying.	
n		-	n6	-	Light drive.	
Interference	p	-	p6	-	Light press.	
	r	-	r6	-	Medium press.	
	s	-	s6	-	Heavy drive.	
	t	-	-	t7	Free fit.	
	u	-	-	u7	Heavy press fit or shrink.	

Table II to provides tolerance for various fits

In the **BASIC HOLE** system, the basic part is the hole, while the shaft is the mating part.  
 In the **BASIC SHAFT** system, the basic part is the shaft, while the hole is the mating part.

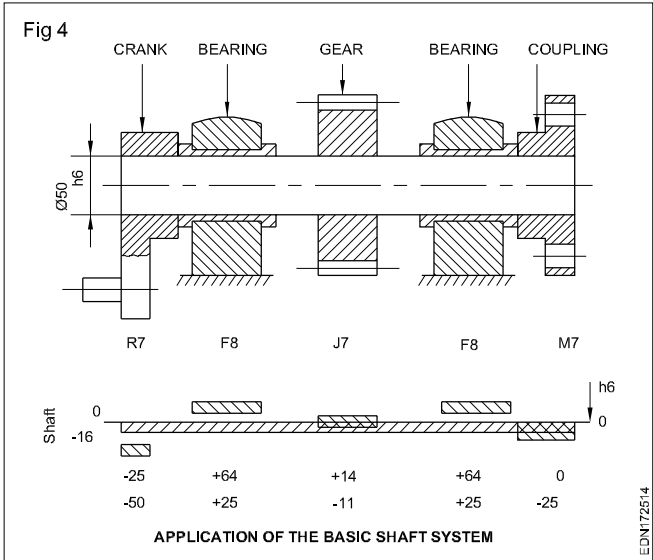

TABLE II

Suggested combinations of tolerance for application of various fits

	Suggested Hole	Combination Shaft
Slack running fits where ease of assembly is important.	H8	c9
Loose running fits e.g. plummer block bearings and loose pulleys.	H8	d8
General loose clearance fits (high speed) e.g. heavily loaded bearings and large electric motor bearings.	H8	e8
Normal running fit e.g. gear box shaft bearings and the bearings of small electric motors.	H7	f7
Precision sliding fit (not running with) e.g. piston and slide valves location fits.	H7	g6
Closest clearance fit for spigots, and links, pins in mechanisms etc.	H7	h6
Transition fit coupling spigots and gear rings clamped to steel hubs.	H8	g7
Slight interference fit e.g. gudgeon pin in piston.	H7	k6
Tight transition fit for accurate location.	H7	m6
Interference fit - commutator on shaft.	H7	p6
Medium driving fit - bushes etc	H7	r6
Heavy driving fit e.g. permanent assemblies.	H7	s6
Force fit for permanent assemblies, coupling on shaft.	H7	t6
Shrink fits - e.g. loco wheels on axle.	H7	u6



TABLE FOR TOLERANCE ZONES & LIMITS (DIMENSIONS IN m m)

		s6	r6	p6	r6	r6	k6	js6	h6	h7	h9	h11	g6	f7	e8	d8	c11	b11	a11	S7	R7	P7	N7	K7	JS7	H7	H8	H9	H11	G7	F8	E9	D10	C11	B11	A11			
From	up to	+20	+16	+12	+10	+6	+3	-3	0	0	0	0	-2	-6	-14	-20	-60	-140	-270	-14	-10	-6	4	0	+5	+10	+14	+25	+60	+12	+20	+39	+60	+120	+200	+330			
		+14	+10	+6	0	-3	-6	-8	-10	-16	-25	-60	-8	-16	-28	-45	-120	-200	-330	-24	-20	-16	-14	-10	-5	+2	+6	+14	+20	+39	+60	+120	+200	+330	+270				
Over	up to	+23	+20	+16	+12	+9	+4	-4	0	0	0	0	-4	-10	-20	-30	-70	-140	-270	-15	-11	-8	-4	+3	+6	+12	+18	+30	+75	+16	+28	+50	+78	+145	+215	+345			
		+19	+15	+12	+8	+1	-4	-12	-30	-42	-30	-75	-12	-22	-38	-60	-145	-215	-345	-27	-23	-20	-16	-9	-6	+4	+10	+20	+40	+70	+140	+270	+420	+570	+720				
Over	up to	+32	+28	+24	+19	+10	+4.5	-9	0	0	0	0	-5	-13	-25	-40	-80	-150	-280	-17	-13	-9	-4	+5	+7.5	+15	+22	+36	+90	+20	+35	+61	+98	+170	+240	+370			
		+23	+19	+15	+10	+1	4.5	-14	-28	-47	-36	-90	-14	-28	-47	-76	-170	-240	-370	-32	-28	-24	-19	-10	-7.5	0	0	0	0	+5	+13	+25	+40	+80	+150	+280			
Over	up to	+39	+34	+29	+23	+12	+5.5	0	0	0	0	0	-6	-16	-32	-50	-95	-150	-290	-21	-16	-11	-5	+6	+9	+18	+27	+43	+110	+24	+43	+75	+120	+205	+260	+400			
		+28	+23	+18	+12	+1	-5.5	-11	-34	-59	-43	-110	-17	-34	-59	-93	-205	-260	-400	-39	-34	-29	-23	-12	-9	0	0	0	0	+7	+16	+32	+50	+95	+150	+290			
Over	up to	+48	+41	+35	+28	+15	+6.5	0	0	0	0	0	-7	-20	-40	-65	-110	-160	-300	-27	-20	-14	-7	+6	+10.5	+21	+33	+52	+130	+28	+53	+92	+149	+240	+290	+430			
		+35	+28	+22	+15	+2	-6.5	-13	-21	-41	-52	-130	-20	-41	-73	-117	-240	-290	-430	-48	-41	-35	-28	-15	-10.5	0	0	0	0	+7	+20	+40	+65	+110	+160	+300			
Over	up to	+59	+50	+42	+33	+18	+8	0	0	0	0	0	-9	-25	-50	-80	-120	-170	-310	-34	-25	-17	-8	+7	+12.5	+25	+39	+62	+160	+34	+64	+112	+180	+280	+330	+470			
		+43	+34	+26	+17	+2	-8	-16	-25	-50	-62	-160	-25	-50	-89	-142	-290	-340	-480	-59	-50	-42	-33	-18	-12.5	0	0	0	0	+9	+25	+50	+80	+130	+180	+290	+340	+480	
Over	up to	+72	+60	+51	+39	+21	+9.5	0	0	0	0	0	-10	-30	-60	-100	-140	-190	-340	-42	-30	-21	-9	+9	+15	+30	+46	+74	+190	+40	+76	+134	+220	+330	+380	+530			
		+53	+41	+32	+20	+2	-9.5	-19	-30	-60	-74	-190	-29	-60	-106	-174	-330	-380	-530	-72	-60	-51	-39	-21	-15	+30	+46	+74	+190	+40	+76	+134	+220	+330	+380	+530			
Over	up to	+78	+62	+51	+37	+23	+11	0	0	0	0	0	-12	-36	-72	-120	-170	-220	-380	-38	-24	-10	-10	+10	+17.5	+35	+54	+87	+220	+47	+90	+159	+260	+390	+440	+600			
		+59	+43	+32	+20	+3	-11	-22	-35	-71	-87	-220	-34	-71	-126	-207	-400	-460	-630	-101	-76	-59	-45	-25	-17.5	0	0	0	0	+12	+36	+72	+120	+180	+240	+360	+410		
Over	up to	+117	+88	+68	+45	+25	+12.5	0	0	0	0	0	-14	-43	-85	-145	-230	-260	-460	-77	-48	-20	-45	+12	+20	+40	+63	+100	+250	+54	+106	+185	+305	+460	+530	+770			
		+92	+63	+45	+25	+3	-12.5	-25	-40	-83	-100	-250	-39	-83	-148	-245	-460	-530	-770	-125	-90	-68	-52	-28	-20	+40	+63	+100	+250	+54	+106	+185	+305	+460	+530	+770			
Over	up to	+133	+93	+68	+43	+28	+14.5	0	0	0	0	0	-15	-50	-100	-170	-230	-260	-460	-93	-63	-33	-14	+13	+23	+46	+72	+115	+290	+61	+122	+215	+355	+550	+670	+1030			
		+108	+68	+43	+28	+4	-14.5	-29	-46	-96	-115	-290	-44	-96	-172	-285	-550	-670	-1030	-159	-109	-79	-60	-33	-23	+46	+72	+115	+290	+61	+122	+215	+355	+550	+670	+1030			
Over	up to	+151	+106	+77	+51	+33	+16	0	0	0	0	0	-17	-56	-110	-190	-300	-480	-920	-138	-74	-36	-14	+16	+26	+52	+81	+130	+320	+69	+137	+240	+400	+620	+800	+1240			
		+122	+77	+56	+34	+4	-16	-32	-52	-108	-130	-320	-49	-108	-191	-320	-630	-800	-1240	-190	-126	-88	-66	+16	+26	+52	+81	+130	+320	+69	+137	+240	+400	+620	+800	+1240			
Over	up to	+226	+144	+98	+73	+40	+18	0	0	0	0	0	-18	-62	-125	-210	-360	-600	-1200	-169	-87	-41	-16	+17	+28.5	+57	+89	+140	+360	+75	+151	+265	+440	+720	+960	+1500			
		+198	+108	+62	+37	+4	-18	-36	-57	-119	-140	-360	-54	-119	-214	-350	-760	-960	-1560	-226	-144	-98	-73	-40	+17	+28.5	+57	+89	+140	+360	+75	+151	+265	+440	+720	+960	+1500		
Over	up to	+272	+166	+108	+80	+45	+20	0	0	0	0	0	-20	-68	-135	-230	-440	-760	-1500	-209	-103	-45	-17	+18	+31.5	+63	+97	+155	+400	+83	+165	+290	+480	+840	+1160	+1900			
		+232	+126	+68	+40	+5	-20	-40	-63	-131	-155	-400	-60	-68	-135	-230	-880	-1160	-1900	-272	-166	-108	-80	+18	+31.5	+63	+97	+155	+400	+83	+165	+290	+480	+840	+1160	+1900			
Over	up to	+292	+172	+112	+68	+40	+20	-40	-63	-131	-155	-400	-60	-68	-135	-230	-880	-1160	-1900	-272	-166	-108	-80	+18	+31.5	+63	+97	+155	+400	+83	+165	+290	+480	+840	+1160	+1900			
		+252	+132	+68	+40	+5	-20	-40	-63	-131	-155	-400	-60	-68	-135	-230	-880	-1160	-1900	-272	-166	-108	-80	+18	+31.5	+63	+97	+155	+400	+83	+165	+290	+480	+840	+1160	+1900			

Nominal size range

**Sizes and layout of drawing sheets - Selection of sizes, title Block, its position & content and item reference on drawing sheet (item list)**

**Designation of sheets:** The drawing sheets are designated by symbols such as A0, A1, A2, A3, A4 and A5. A0 being the largest. Table 1 below gives the length and breadth of the above sizes of sheets. (Trimmed and untrimmed)

The relationship between two sides are same as that of a side of a square and its diagonal.

TABLE 1

Designation	Trimmed size	Untrimmed size
A0	841 x 1189	880 x 1230
A1	594 x 841	625 x 880
A2	420 x 594	450 x 625
A3	297 x 420	330 x 450
A4	210 x 297	240 x 330
A5	148 x 210	165 x 240

**Layout of drawing sheet:**

As a standard practice sufficient margins are to be provided on all sides of the drawing sheet. The drawing sheet should have drawing space and title page. A typical layout of a drawing sheet is shown in the (Fig 1 & 2).

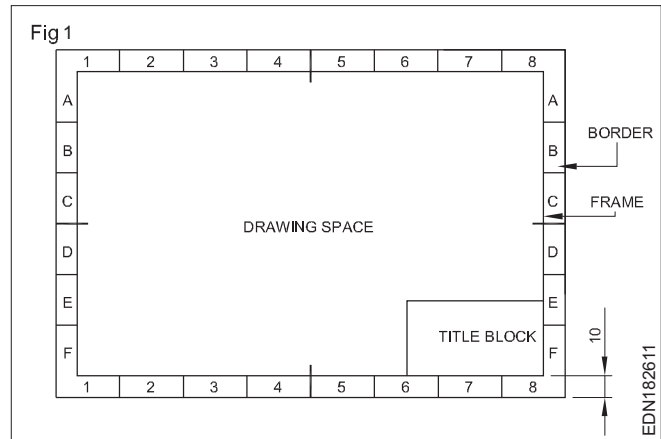

**Title Block - 1**

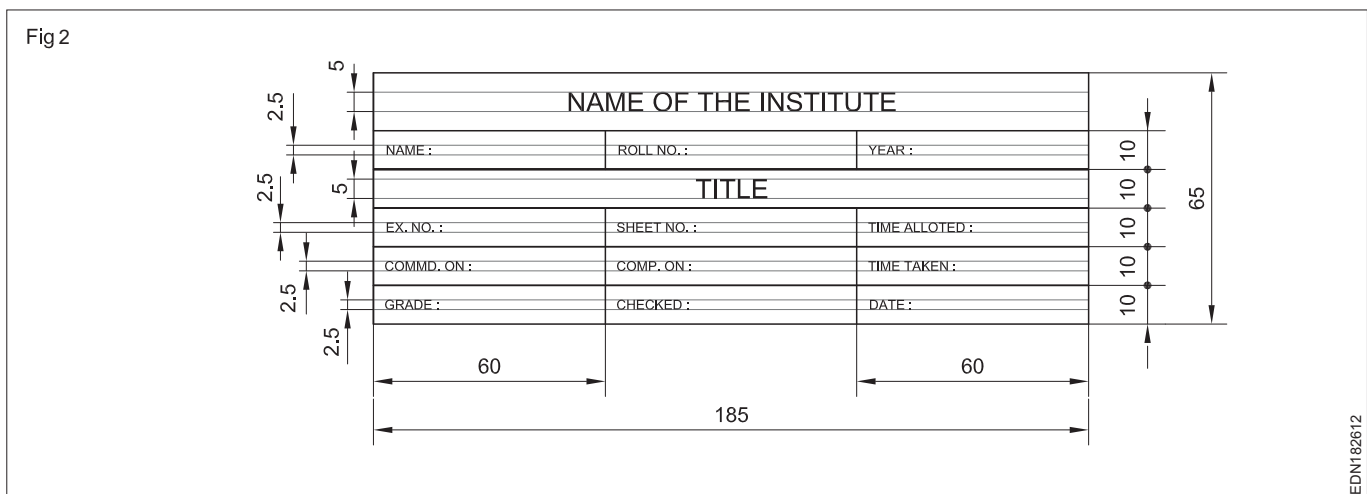

**Title Block - 2**

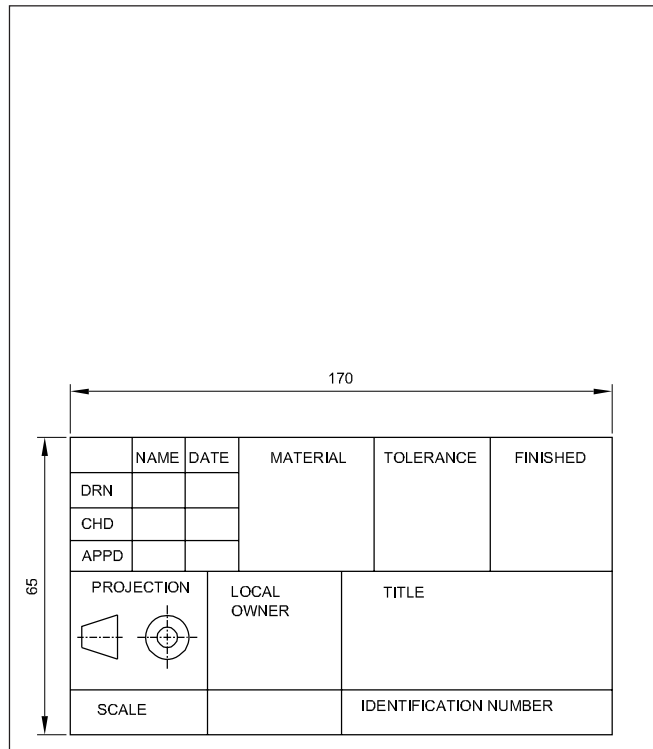

**Title Block - 3**

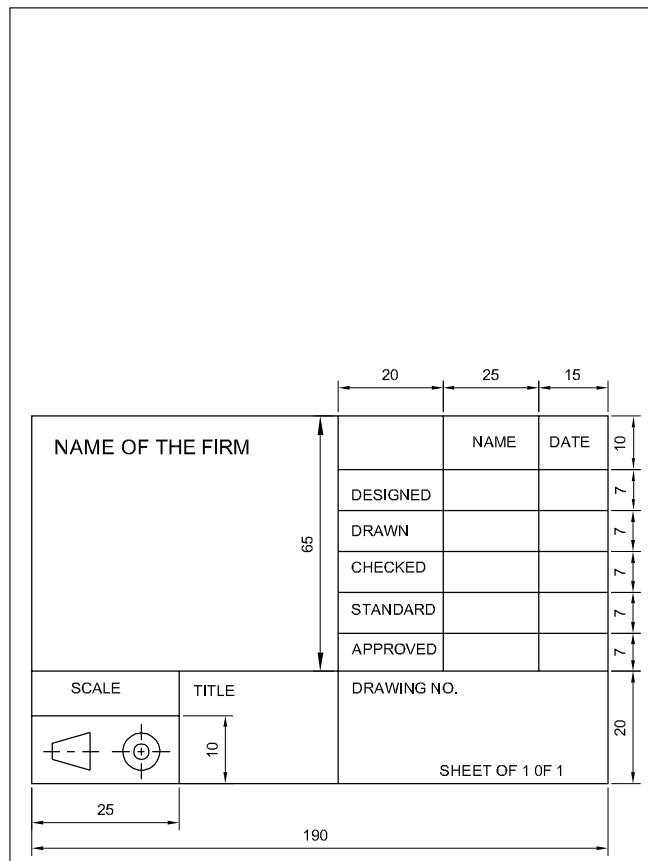

**Title Block - Position and content - 1**

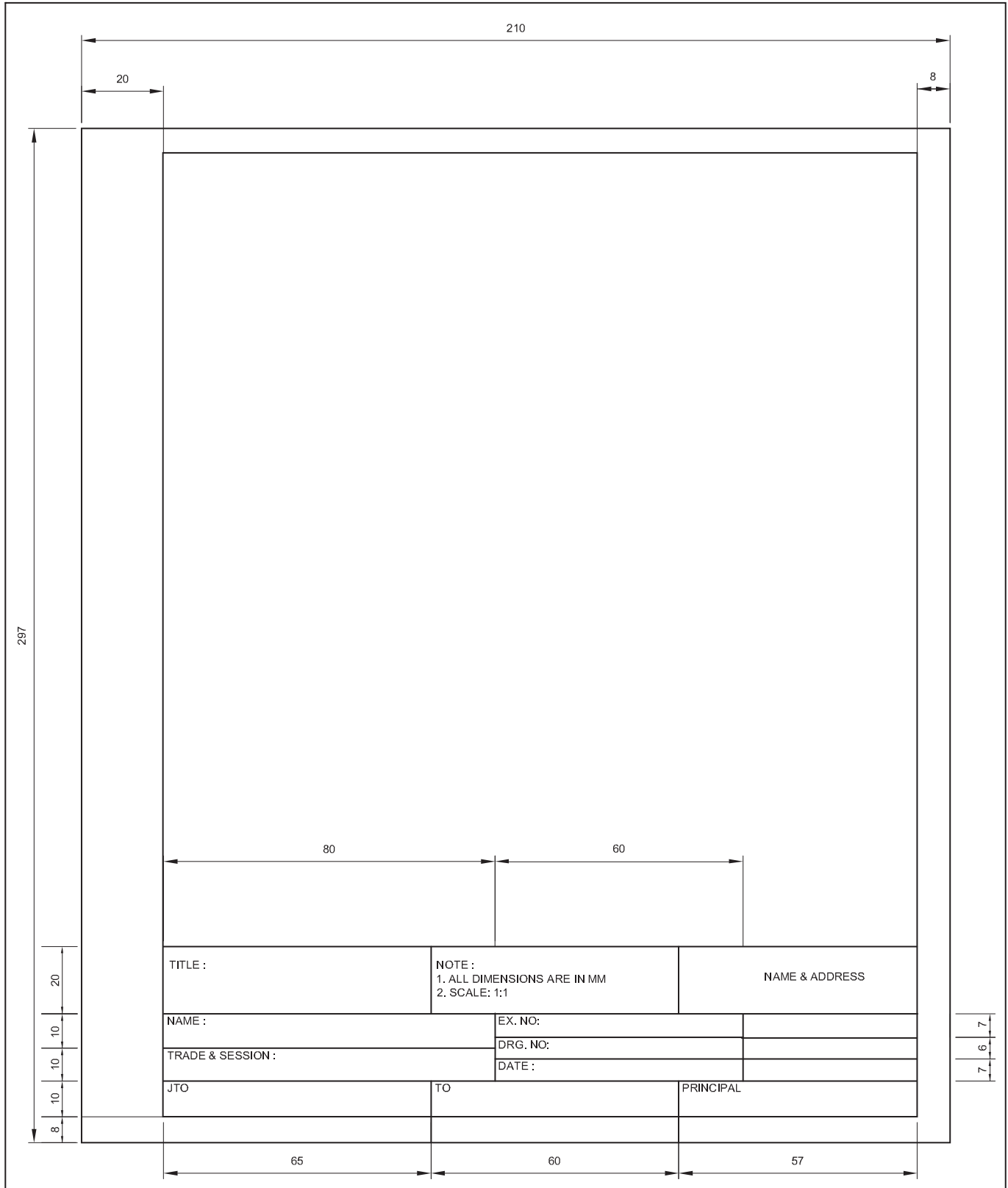

### Title Block - Position and content - 2

DO NOT SCALE

REVISIONS			
SL.N	DESCRIPTION	DATE	APPX.
A	M12 WAS $\frac{1}{2}$ WHIT.	14-12-18	A.W.B

4			
3			
2			
1	A7325	VALVE BODY	1
DRG OR PART NO.	DESCRIPTION	QTY.	

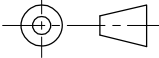
UNLES OTERWISE STATED ALL DIMINTIONS IN MILLIMETRES. TOLERANCES LINEAR: ANGULAR:		DRN 1:1:78 JKL	(NAME OF FIRM)	
	MATERIAL CAST STEEL	CKO 2:1:78 MJN		(TITLE OF DWG.)
	DRAFTING STANDARD AS 1100	FINISH AS MACHINED		
				ISSUED 4:2:78 PFP
		SIZE A3	DRG NO A24641	
		SCALE 1:2	SHEET 1 OF 1	

EDN1826T3

### Item Reference on Drawing Sheet

05	TIGHTENING PIN	01	MILD STEEL	
04	WORKPIECE	01	ANY MATL.	
03	SCREW ROD	01	STD.	
02	"U" CLAMP	01	CAST IRON	
01	"V" BLOCK	01	CAST IRON	
	DESCRIPTION OF ITEM	QTY/ASSY	MATERIAL	REMARKS
<b>BILL OF MATERIALS</b>				

The drawing sheet on which the drawings to be prepared should be prepared first by following the procedure given below

- 1 Take A4/A3 drawing sheet.
- 2 Mark the borders and draw the title block as mentioned below.

- 3 Follow the same procedure for A3 drawing sheet where the title block is to be drawn right side bottom corner and the border dimensions remain same.

- 4 Title block to be drawn whenever the title of the drawing changes. Eg. for the geometrical construction chapter the title block may be drawn in the first sheet only where as on the remaining sheets borders to be drawn before they are used for preparing drawings.

Method of presentation of engineering drawing - Pictorial view and isometric view

**Pictorial drawing:** Even a common man can understand easily the shape of an object quickly by a picture or by a pictorial drawing. It is also called as three dimensional drawing.

Pictorial drawings are very useful for describing the shape of a piece part or component, even though they have a distorted look.

Three type of pictorial drawings are (Fig 1)

- Isometric drawing
- Oblique drawing
- Perspective drawing

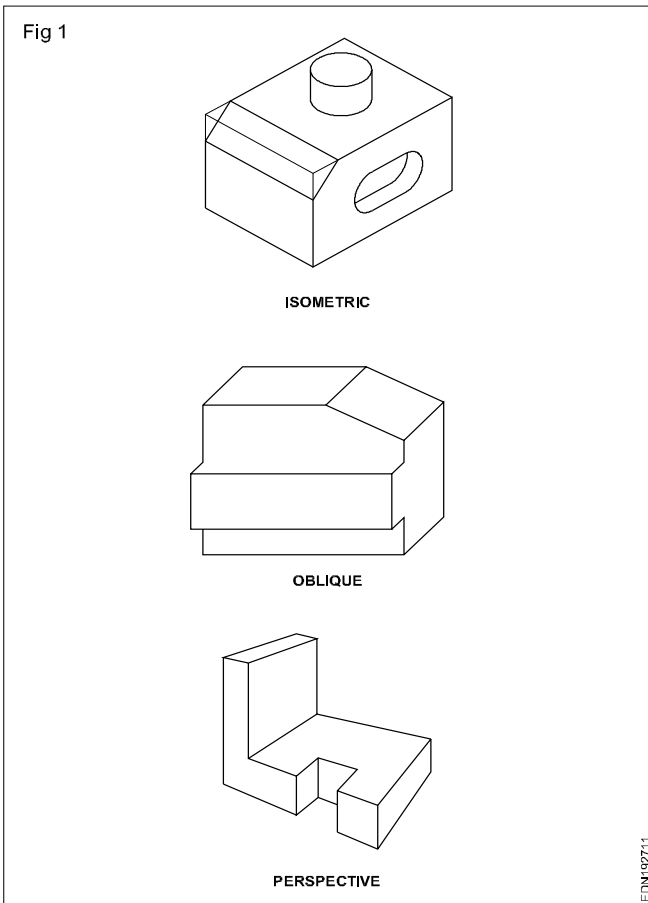

Out of the above three types, isometric drawings are very much preferred by machine shop and metal working trades group. But perspective drawings are popular in civil engineering group of trades.

**Isometric drawing:** In an isometric drawing the three mutually perpendicular edges of a cube are at an angle of  $120^\circ$  with each other. Instead of drawing the edges in the above said way, first we can also start from point 'a'. At this point also three mutually perpendicular edges met while two of these edges make  $30^\circ$  to horizontal, the other edge is vertical. After drawing two  $30^\circ$  lines and one vertical line, parallel lines are drawn to complete cube. (Fig 2)

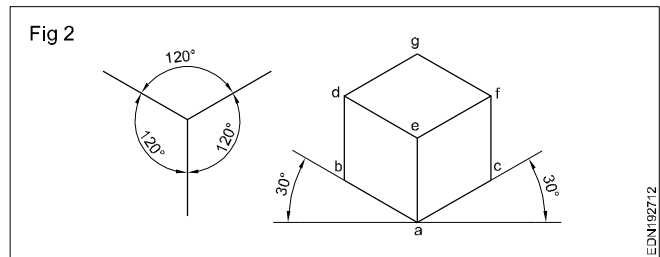

These three lines which represent the mutually perpendicular edges are isometric axes. Generally those axes are kept in four positions. (Fig 3)

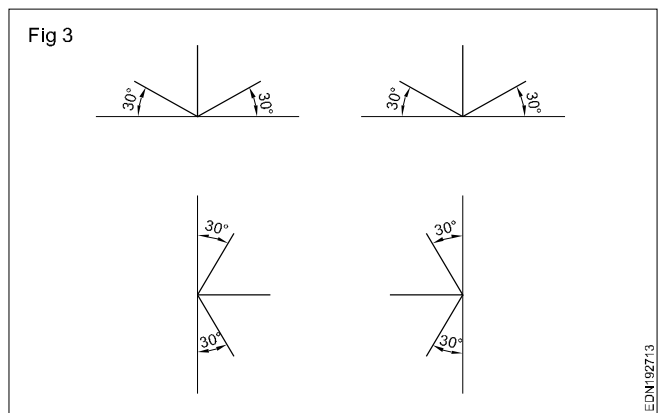

So to draw the isometric drawing, first draw the three mutually perpendicular edges, set other linear dimensions and complete the figure. (Fig 4)

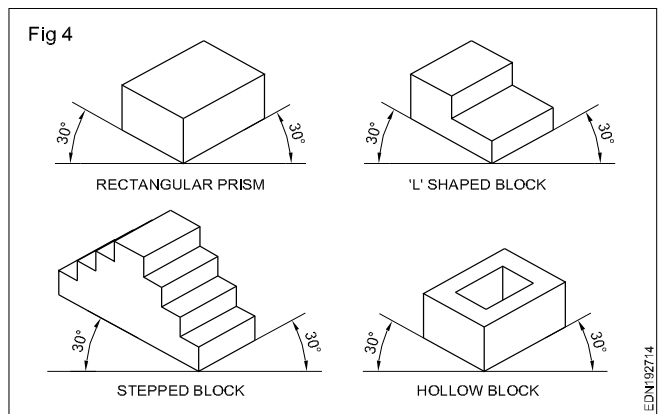

**Isometric and non-isometric lines:** Fig 5 shows the isometric view of a shaped block. Here all lines except AB, BC and DE are parallel to isometric axis. Such lines which are parallel to isometric axes are called isometric lines whereas such lines AB, BC and DE which are not parallel to isometric axes are called non-isometric lines.

The length of non-isometric lines will not follow the scale used for isometric lines. To prove this point consider the non-isometric lines AB or BC. The true length of both AB and BC is 5 cm while BC will be longer. Because of this reason non-isometric lines are drawn first by locating their starting and end points on isometric lines.

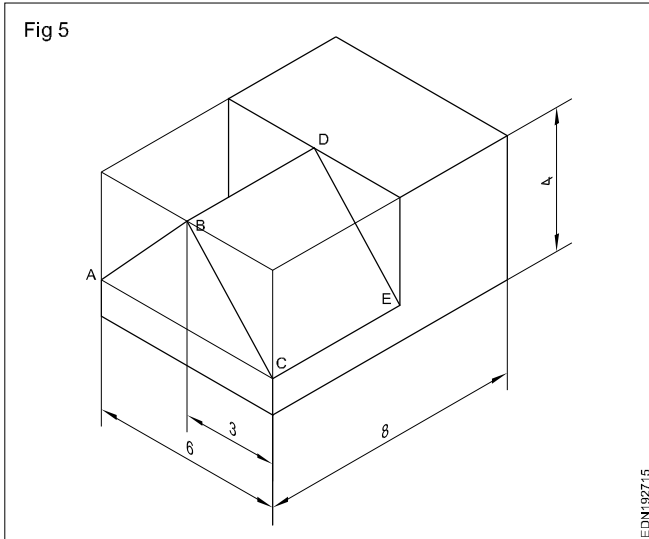

To locate the end points and to draw the non-isometric lines two methods are employed. They are

- Box method
- Off-set method

**Box method:** The object is assumed to be inside a rectangular box. Starting and end points are located and marked. By joining the points isometric view is drawn.

**Off-set method:** This method is most suited for the objects consisting of number of planes at a number of different angles.

**These methods are not only useful for isometric views involving non-isometric lines but also for the isometric views involving isometric lines.**

**Box method of drawing a pyramid**

**Example**

Draw an isometric view for the triangular pyramid shown in Fig 6 using a box method.

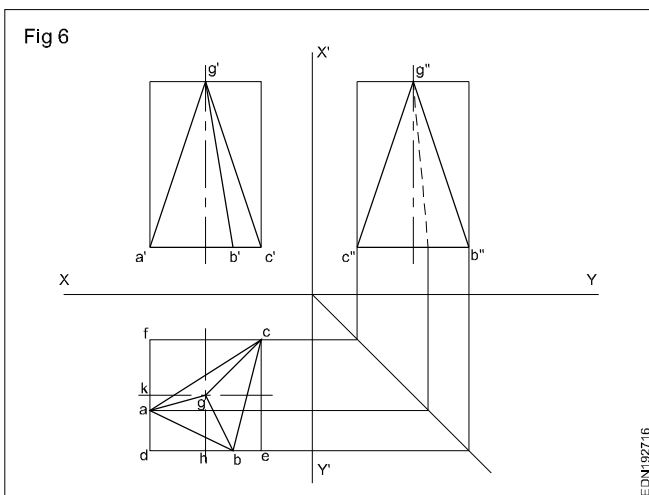

- Construct a rectangular box to the overall size of the pyramid (Fig 7a)
- Mark the distances ad and be from the plan of Fig 7b in the base of the box.

- Mark the distances kg and dh on the top face of box. (Fig 7c)
- Join the points ab, bc, ca, ag, bg and cg and complete the isometric view of the pyramid in box method. (Fig 7c)

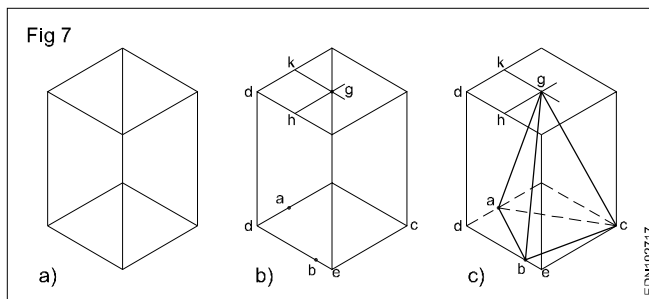

**Off-set method of drawing a pyramid**

**Example**

Same triangular pyramid (Fig 6) is considered for drawing isometric view using offset method.

- Draw an isometric square/rectangle considering the corners of the base of the pyramid. (Fig 8a)
- With the help of Fig 6 (Plan) locate all the three corners of the base P, Q and r using offset method.
- Locate the position of vertex 'O' on base by referring the Fig 6 (Plan) using the same offset method. (Fig 8b)
- Draw the vertical line O'-O to the height of the pyramid.
- Join the corners of the base.
- Join the vertex O' with the corners of the base and complete the pyramid. (Fig 8c)

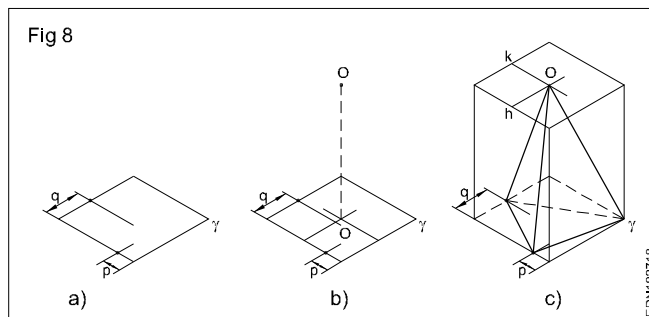

**Angles in isometric drawing:** The angles of inclined surfaces will not have the value in the isometric drawing, but will be more in some cases and less in other cases.

For example, in the isometric view of prism shown in Fig 9 the true value of all the angles is 90°. But in isometric drawing the angles are 60° in some cases and 120° in others.

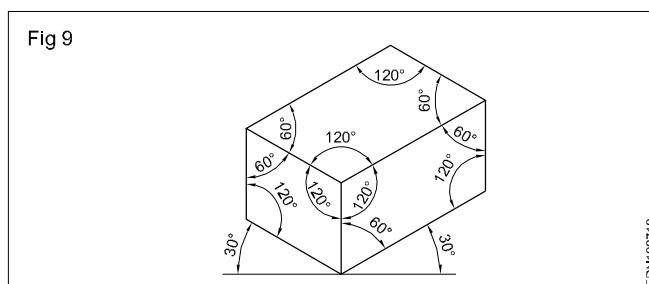

**Isometric circles:** The term isometric circle refers to the shape of circle in isometric view. An isometric circle will be elliptical in shape as shown in Fig 10. While drawing isometric view of cylindrical features isometric circles will have to be used. (Fig11)

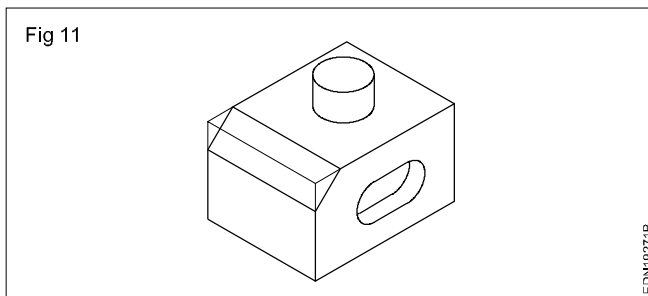
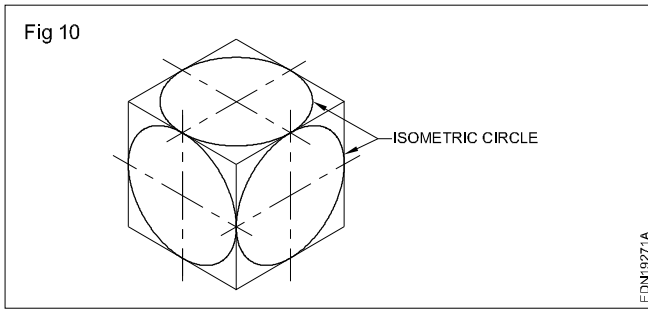

An isometric circle can be drawn either by plotting offset method or by arc method.

**Plotting method (Fig 12)**

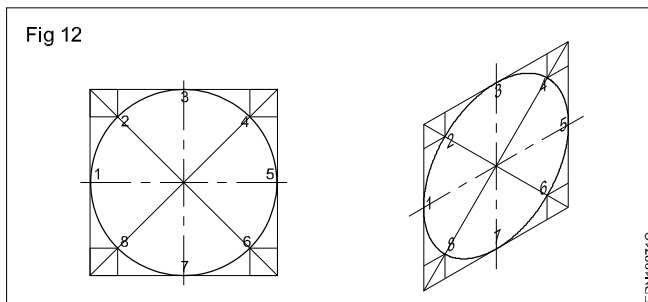

- Draw a square of side equal to the dia of circle and inscribe the circle.
- Divide the circle into any number of equal parts and mark points such as 1,2,3,4,5,6,7,8 on the circle.
- Through the points 1,2,3 etc draw lines parallel to the both the axis of cylinder.
- Draw isometric view of the square.
- Mark points corresponding to 1,2,3....8 with isometric view of the square as points 1',2',3'....8'.
- Join these points with a smooth curve to form an ellipse.

**Note: The orientation of the isometric circle will depend upon the plane on which the circular feature exists.**

**Arc method:** Isometric circles drawn by offset method is the ideal method of making isometric circles as the ellipse obtained this way is geometrically true. But by free hand we cannot get a clear line.

Fig 13 shows the construction of isometric circle in 3 different orientation by arc method. Four arcs are to be drawn and the centres are  $C_1, C_2, B$  &  $D$ . While centre  $B$  and  $D$  are the corner of the rhombus  $C_1$  and  $C_2$  are intersection points of the longer diagonal with lines from points  $B$  or  $D$  to the mid point of the side of the rhombus.

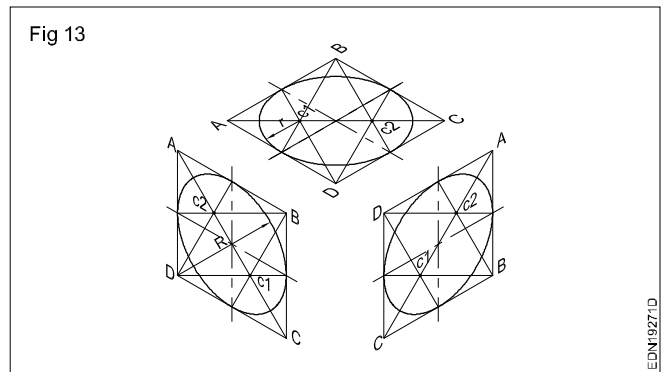

**Note: The arc method gives a clean ellipse, but this ellipse drawn this way will slightly deviate from true ellipse. It does not matter for our purpose.**

The isometric circles can also be drawn using templates which can be bought from stationary shops.

**Isometric view of profiles:** The profile  $M'N'$  of the block shown in Fig 14 is irregular in nature. The isometric views of such lines may be drawn by offset method described earlier. The points 1',2',3' and 4' lie on the profile. Lines  $A'1', B'2', C'3', D'4'$  are isometric lines and their length are same both in Fig 14 & Fig 15. After getting the points 1,2,3 & 4, they joined by smooth curve.

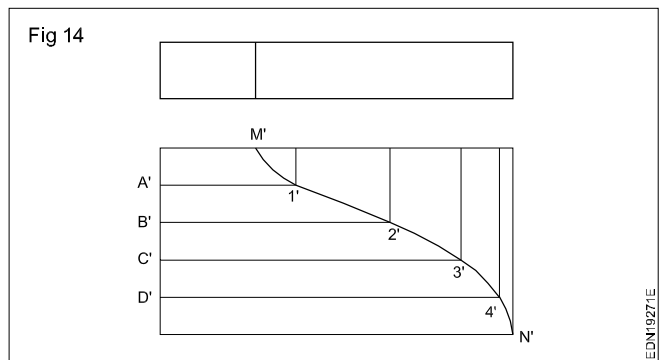

**Note: In offset method more the number of points, better will be the accuracy of the curve.**

**Isometric drawing of sphere:** The Orthographic view of a sphere seen from any direction is a circle of diameter equal to the diameter of the sphere. Hence, the isometric drawing of a sphere is also a circle of the same diameter.

The front view and the top view of a sphere resting on flat surface are shown in Fig 16a.

'O' as its centre, D is the diameter and P is the point of contact with the surface.



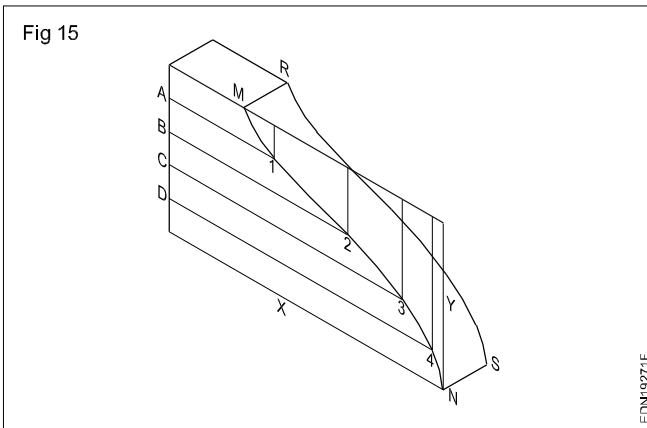

Assume a vertical section the centre of the sphere. Its shape will be a circle of diameter  $D$ . The isometric drawing of this circle are ellipses 1 & 2 Fig 16(b) drawn in two different vertical positions around the same centre 'O'. The major axis in each case is equal to  $D$ . The distance of the point P from the centre 'O' is equal to the isometric radius of the sphere.

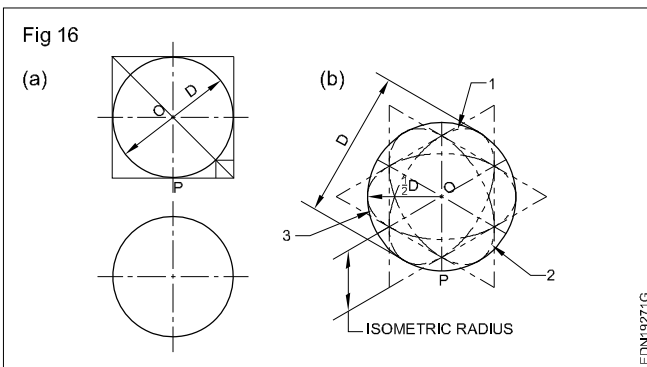

Again, assume a horizontal section through the centre of the sphere.

The isometric drawing of this circle is shown by the ellipse 3, drawn in a horizontal position around the same centre 'O'. In all the three cases 1,2 & 3 the outermost points on the ellipse from the centre 'O' is equal to  $1/2 D$ .

Thus, it can be seen that in an isometric drawing, the distances of all the points on the surface of a sphere from its centre are equal to the radius of the sphere. Hence, the isometric projection of a sphere is a circle whose diameter is equal to the true diameter of the sphere. (Fig 17)

Also the distance of the centre of the sphere from its point of contact with the flat surface is equal to the isometric radius  $OP$  of the sphere.

It is therefore of the utmost importance to note that isometric scale must invariably be used while drawing isometric projection of solids in conjunction with spheres or having spherical parts.

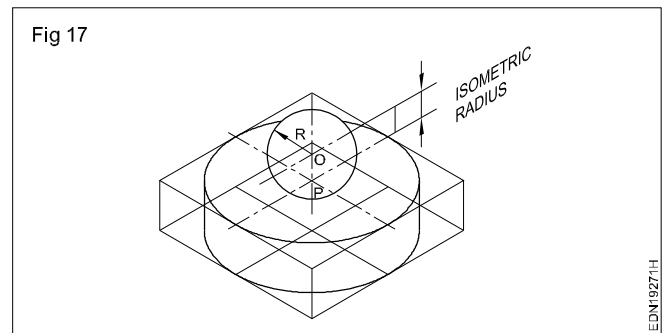

## Practice of isometric views

Draw the following isometric figures (Ex.1 to 8) in A3/A4 Sheets. Follow the procedure given wherever necessary.

### Procedure

**1 Draw the isometric drawing of a rectangular prism of base 30 mm x 40 mm and the height 60 mm. (Fig1)**

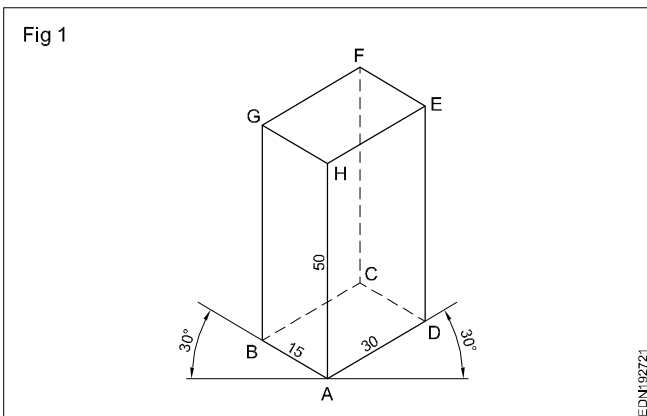

- Draw the three isometric axes through point 'A'.
- Mark  $AB = 15$  mm,  $AD = 30$  mm and  $AH = 60$  mm representing the three sides of prism.

- Draw two vertical lines parallel to the line AH through points B and D.
- Similarly draw two more lines parallel to AB and AD through point H.
- Mark G and E the intersecting points.
- Draw lines parallel to GH and HE through points G and E intersecting point is F.
- Draw lines parallel to AB & AD through points D and B respectively intersecting at C.
- Join CB & CD with dash lines.
- Join F and C also with dash lines.
- Rub off the construction lines and complete the prism.

**2 Draw the isometric view of the stepped block given in Fig2.**

- Draw the isometric view of a rectangular prism of dimensions equal to the overall size of the block  $45 \times 25 \times 30$  mm.
- Draw the lines JD, DE, EF, FH, HI and IJ using the measurements given in the figure.
- Rub off SR, RD, SJ, SH and RF.

- Darken the remaining lines of the stepped block.

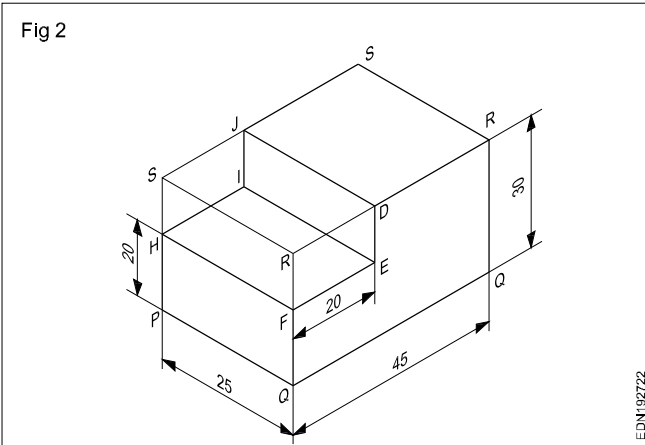

**3 Draw the isometric view of the components shown. (Fig 3)**

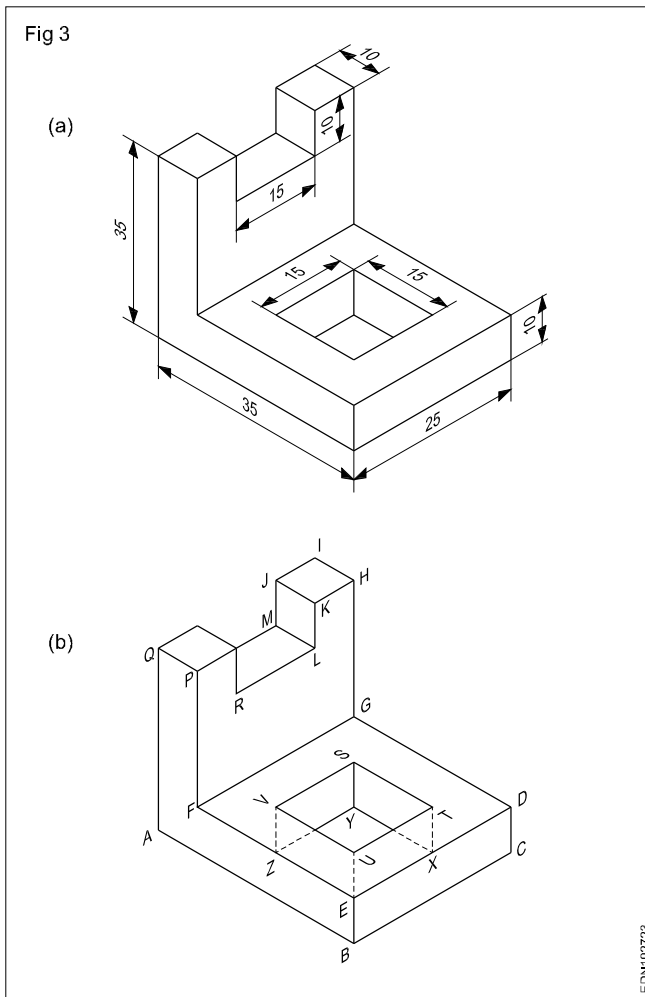

- Draw the stepped block as per dimension. Follow the procedure given in the previous Ex.No.2.
- Mark points UTSV as per dimension on the top of the surface EDGF (Fig 3b)
- Join points UTSV.
- Project vertically downwards from the points UTSV and obtain the point WXYZ at bottom surface such that UW, TX, SY & VZ are equal to 10 mm. Join the point WXYZ and draw the thick lines which are all visible and dotted lines which are not visible.

**Note: All construction lines should be in thin lines. After completion of the isometric views, in each case erase the unwanted lines and construction lines.**

With the experiences gained in previous exercises of drawing isometric views, draw the following exercises 4 & 5 and complete the same.

**4 (Fig 4)**

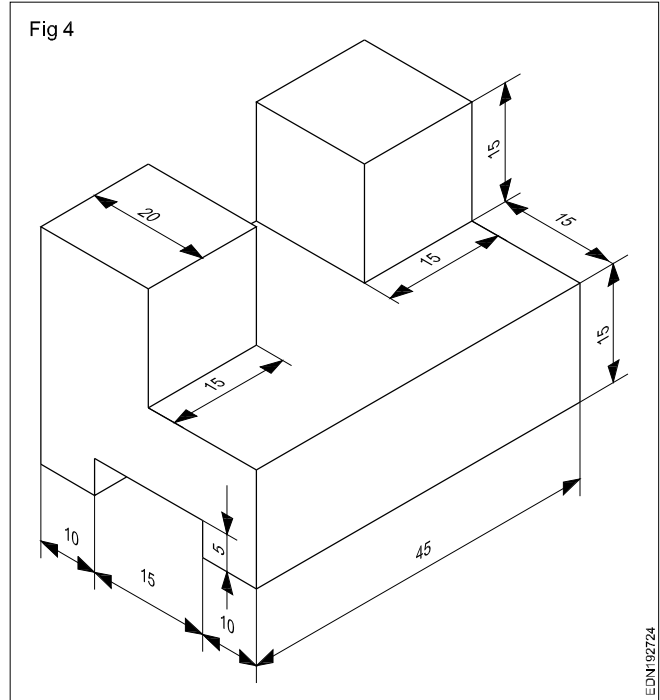

**5 (Fig 5)**

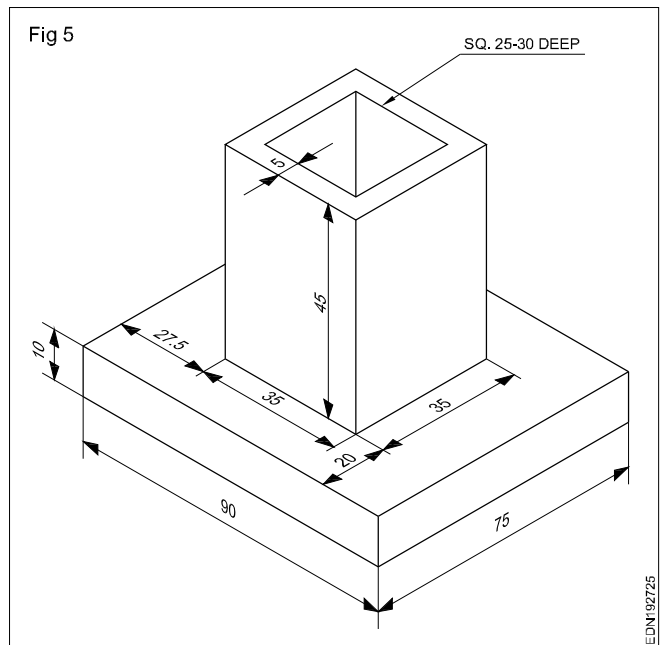

**6 Draw the isometric view of the machined block having non-isometric lines. (Fig 6a)**

- Draw an isometric box. (Fig 6b)
- Mark point A on PS at a distance of 15 mm from P.
- Draw line AB = 25 mm parallel to PQ.

- From B, draw a vertical line cutting RS at L.
- Mark point D on US such that  $UD = 20$  mm.
- Draw a line DC parallel to UT equal to AB.
- Join AD, BC and CL to complete the required isometric view of the block.
- Remove the extra lines and darken the required visible edges.
- Show hidden edges by dashed lines.

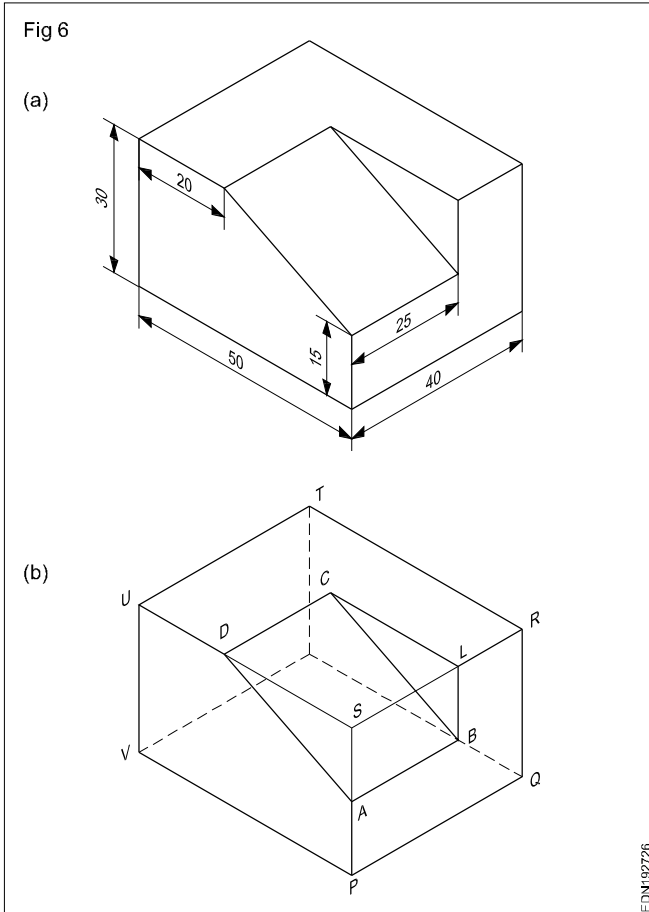

**7 Draw the isometric view of the 'V' block. (Fig 7a)**

- Draw the isometric view of a rectangular box of size 50 x 40 x 30.
- On the face ABFE, draw the lines JN & LN by offset method.
- Similarly draw lines KP & MP.
- Join ML, KJ and PN.
- Erase construction lines and make the remaining line thick and dashes according to the drawing.

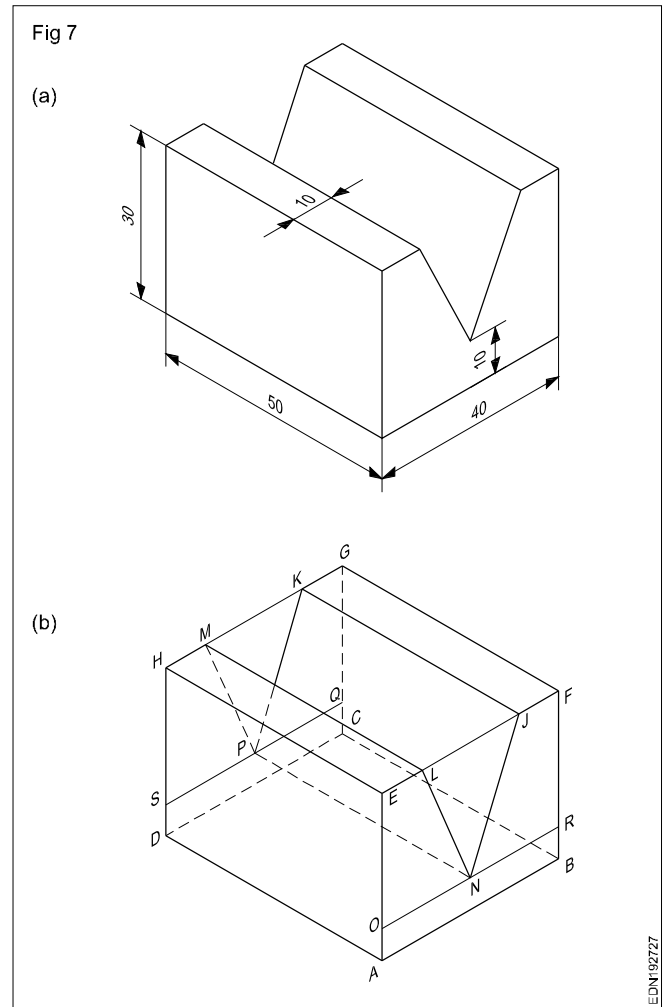

**Draw the isometric drawing of the following slant cut blocks. (Fig 8)**

- In each case draw the isometric view of a rectangular prism to the overall sizes of the each block.
- Follow the procedure adopted in the previous exercises and complete the each isometric view of the blocks.
- Remove the unwanted lines, draw the remaining lines thick and hidden lines as required. Complete the figures.
- Assume the missing dimensions if any proportionally.

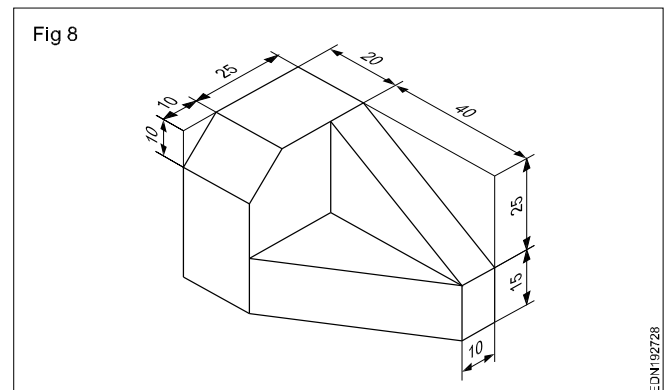

# Pictorial drawing (Oblique drawing)

Oblique drawings are yet another type of pictorial projections, they differ from isometric drawings in two ways.

- In oblique drawing, projections are oblique (inclined) to the plane of projection. whereas in isometric projections projectors are perpendicular to the plane of projection. (Fig 1)

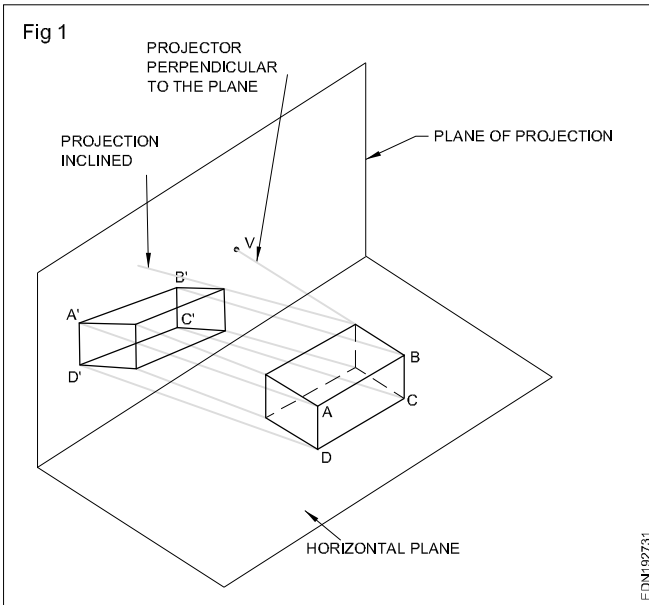

- In an oblique drawing one of the principal faces of the object is kept parallel to the plane of projection, but in isometric, none of the faces of the object is parallel to the plane of projection.

**Even though one of face of the object is positioned parallel to the picture plane, we still get a pictorial view and the projections are inclined to both HP and VP.**

Because one of the principle faces of the object is parallel to the plane of projection, in the oblique projection, the projection of this face and faces parallel to it will appear in true size and shape. In the oblique projection of a prism is shown in Fig 2, the faces ABCD and EFGH are parallel to the plane of projection and they appear to be true in size and shape. The other four faces which are perpendicular to the plane of projection do not appear in true shape. (all these four faces are seen as parallelogram) However the vertical edges of these faces are parallel to the plane of projection and hence the projection of these edges will measure to their true lengths.

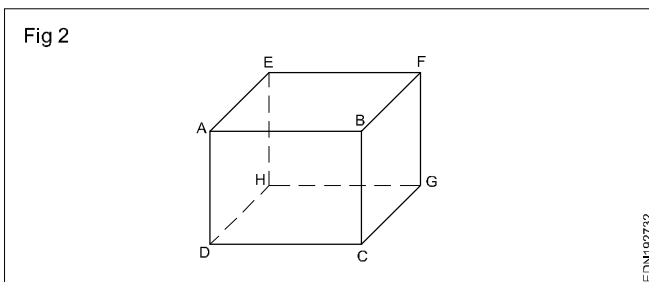

Projection of edges such as AE, DH, BF and CG which are perpendicular to the plane of projection will measure differently depending on the angle of inclination of the projectors. If the inclination of the projectors is 45° the projections of these edges measure to their true lengths. If the angle is less than 45° the projection of such perpendicular edges will measure less than the true length, if the angle of inclination of the projectors is greater than 45°. Projection of such perpendicular edges will measure more than the true length.

Oblique projections nevertheless have an unique advantage what we want to make pictorial drawings of object having curved features. For making isometric views of a curved feature we have first to draw their orthographic views in order to find out the offsets of points lying on the curve. But this difficult procedure is not necessary in the case of oblique views.

For example the component shown in Fig 3 has several curved features. While drawing oblique view of this component the curved features are drawn to true shape using compass. This is relatively easier method in comparison to the drawing of the same component in isometric view.

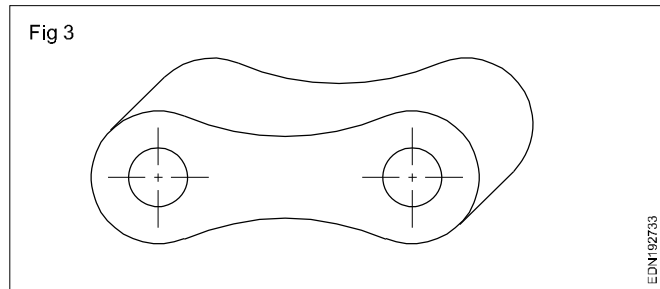

**Inclination of projectors:** While projectors can have any angle of inclination, usually oblique views are drawn to either 45° or 30°. The inclined lines in the oblique drawings are called receding lines (Fig 4) and they are more commonly drawn to 45°. The scale of lines along receding may be 1:1 (true lengths) or 1:2 (half of the true length).

Oblique drawing drawn to 1:1 (Fig 5) are called as **cavalier** projections and those drawn to 1:2 (Fig 6) are called as **cabinet** projections. These two terms are of academic interest only and mostly we refer these views as oblique projections/drawings only.

In comparison a cabinet projection will look less distorted than a cavalier projection.

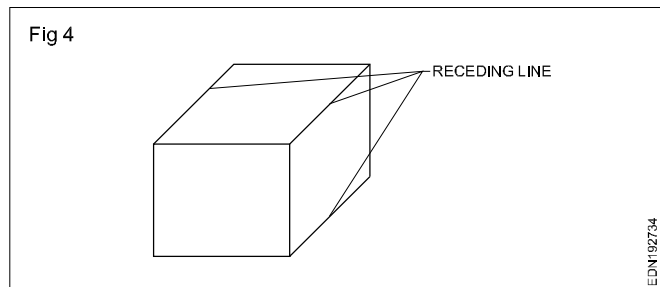

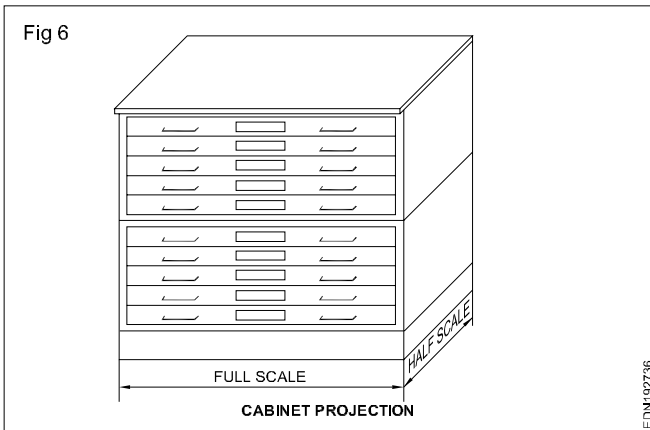
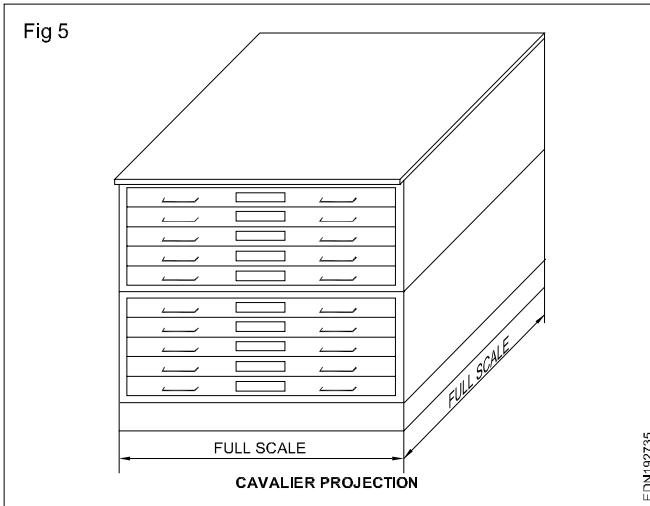

**Procedure for drawing oblique views:** The procedure for creating oblique drawing is very much similar to that for drawing isometric views. To make isometric view we start from drawing three isometric axes at the desired orientation. In oblique drawing also we start by drawing three axes at the desired orientation. But here two of the axes are perpendicular to each other while the third axis (receding axis). Make  $45^\circ$  or  $30^\circ$  to the horizontal. The orientation of the axes may be any one of the four possibilities given in the figure 7.

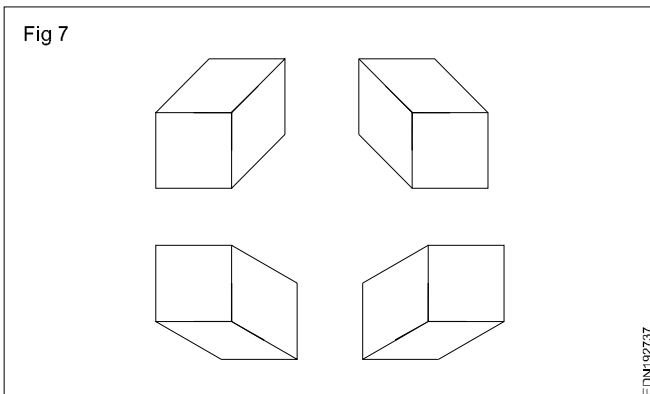

**Object positioning in oblique drawing:** Remember to position the object in such a way as to make best use of the advantage offered by oblique projection. The face that has the maximum curved details should be placed parallel to the plane of projection. See example in Fig 8.

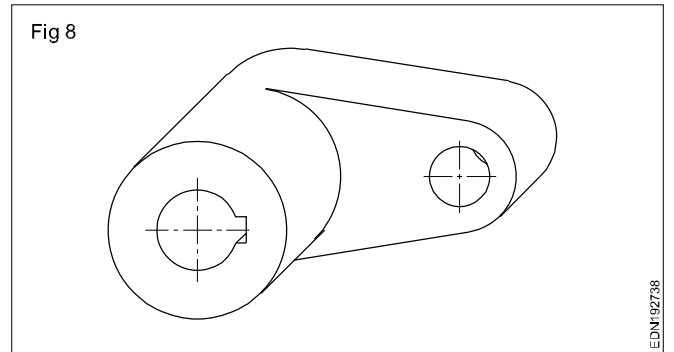

Another point to note is as far as possible, place the longest dimension parallel to the plane of projection. (Fig 9a & b)

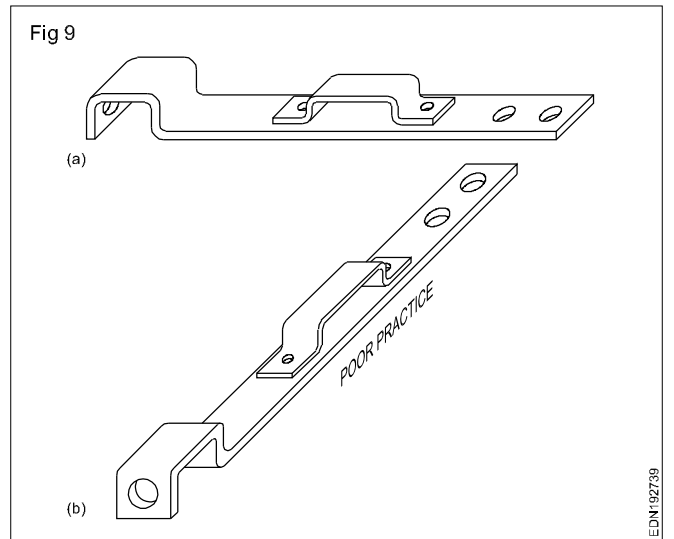

Few examples of oblique drawings are shown in Fig 10.

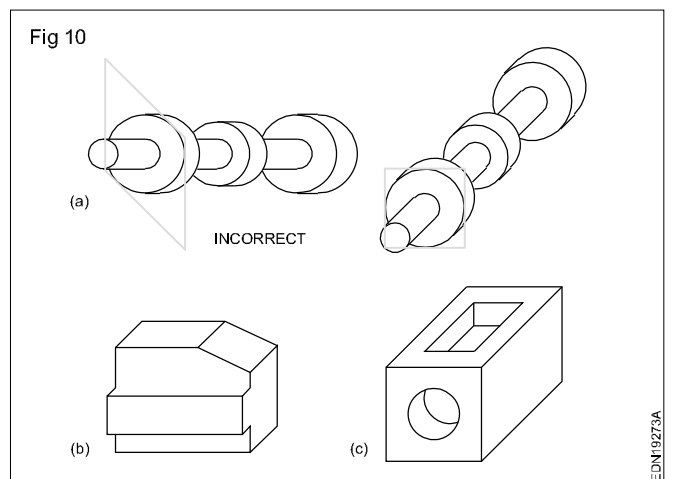

## Method of perspective views

**Perspective** (from Latin: perspicere "to see through") in the graphic arts is an approximate representation, generally on a flat surface (such as paper), of an image as it is seen by the eye. The two most characteristic features of perspective are that objects appear smaller as their distance from the observer increases; (Fig 1) and that they are subject to foreshortening, meaning that an object's dimensions along the line of sight appear shorter than its dimensions across the line of sight.

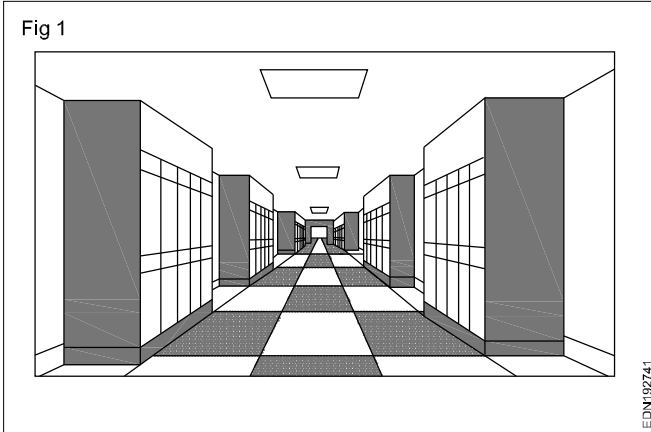

### One-point perspective

A drawing has one-point perspective when it contains only one vanishing point on the horizon line. (Fig 1&2) This type of perspective is typically used for images of roads, railway tracks, hallways, or buildings viewed so that the front is directly facing the viewer.

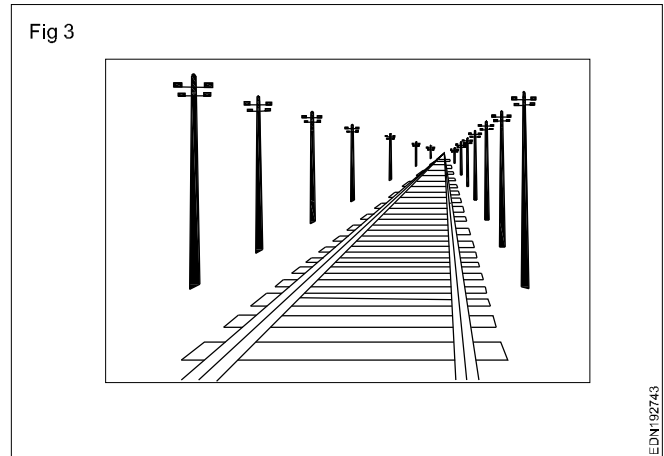
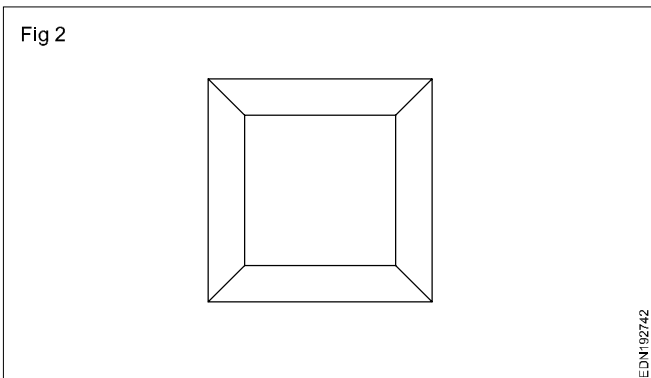

### Two-point perspective

A drawing has two-point perspective when it contains two vanishing points on the horizon line. In an illustration, these vanishing points can be placed arbitrarily along the horizon. (Fig 1&2) Two-point perspective can be used to draw the same objects as one-point perspective, rotated: looking at the corner of a house, or at two forked roads shrinking into the distance, for example. One point represents one set of parallel lines, the other point represents the other. Seen from the corner, one wall of a house would recede towards one vanishing point while the other wall recedes towards the opposite vanishing point.

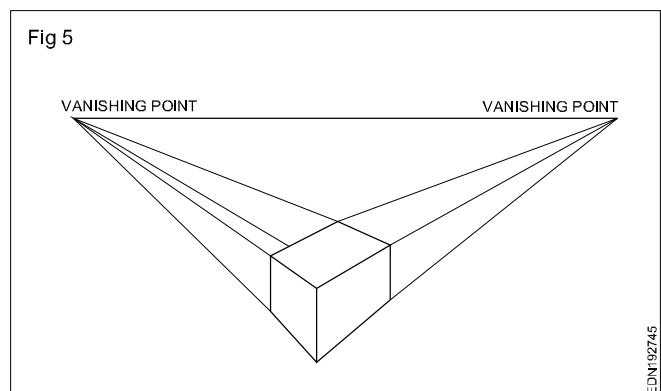
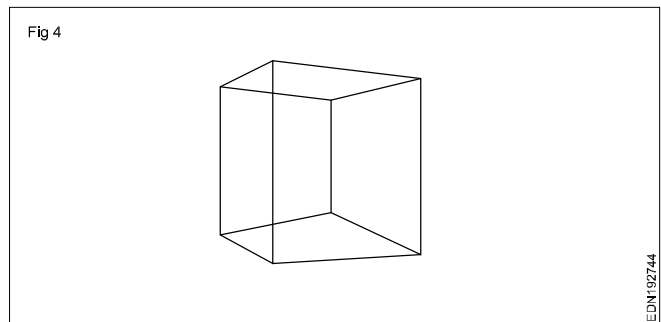

### Three-point perspective

Three-point perspective is often used for buildings seen from above (or below). (Fig 1&2) In addition to the two vanishing points from before, one for each wall, there is now one for how the vertical lines of the walls recede. For an object seen from above, this third vanishing point is below the ground. For an object seen from below, as when the viewer looks up at a tall building, the third vanishing point is high in space.

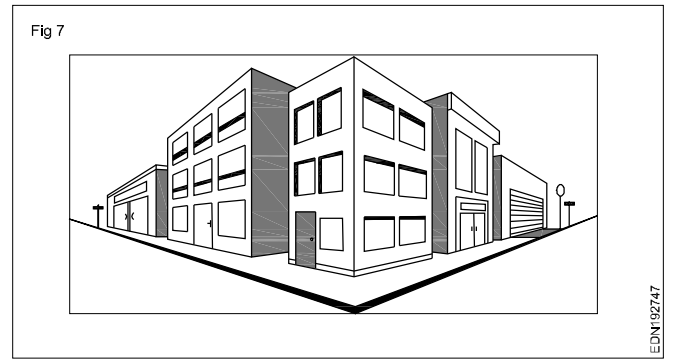
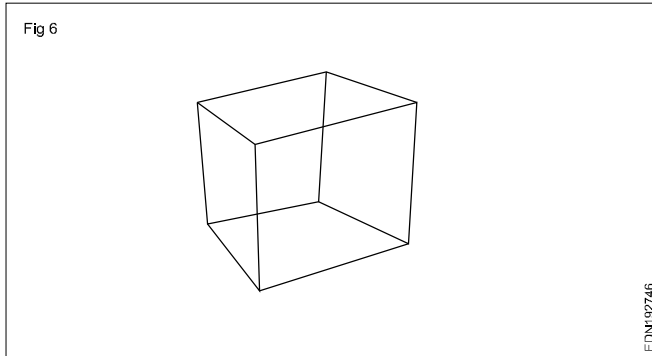

**Method of presentation of engineering drawing - Orthographic view**

<p>Fig 1</p> <p>TOP VIEW FRONT VIEW RIGHT SIDE VIEW FRONT</p>	<p>TOP VIEW FRONT VIEW RIGHT SIDE VIEW</p>
<p>TOP VIEW FRONT VIEW SIDE VIEW FRONT</p>	<p>TOP VIEW FRONT VIEW SIDE VIEW</p>
<p>ISOMETRIC VIEW ORTHOGRAPHIC VIEW TOP VIEW FRONT VIEW SIDE VIEW</p>	<p>TOP VIEW FRONT VIEW SIDE VIEW HIDDEN LINE USE TO SHOW SURFACES THAT ARE NOT DIRECTLY VISIBLE</p>
<p>TOP VIEW FRONT VIEW SIDE VIEW TOP FRONT SIDE</p>	

EDN192811



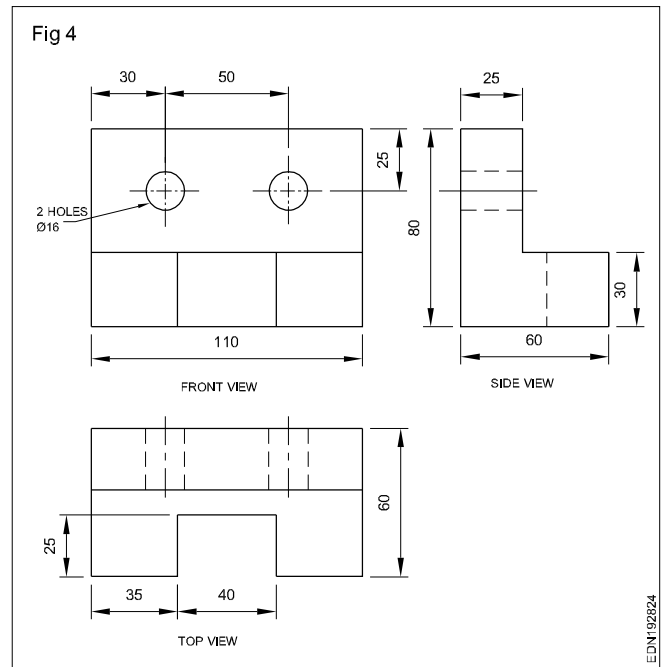
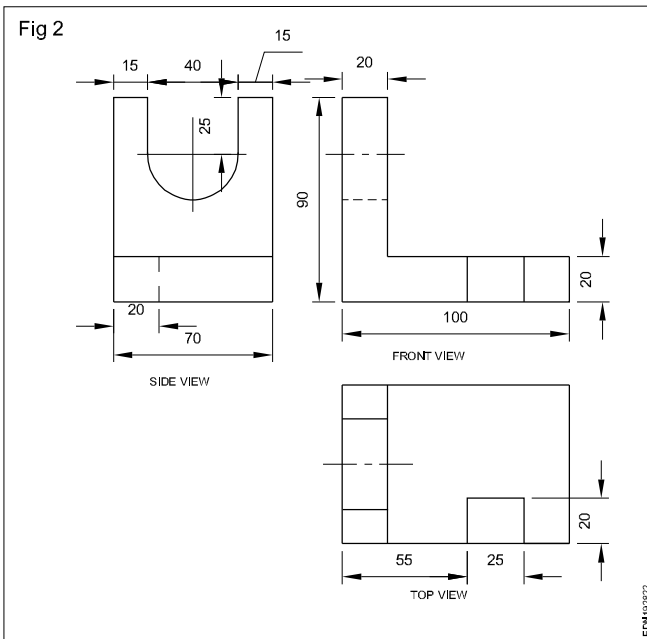
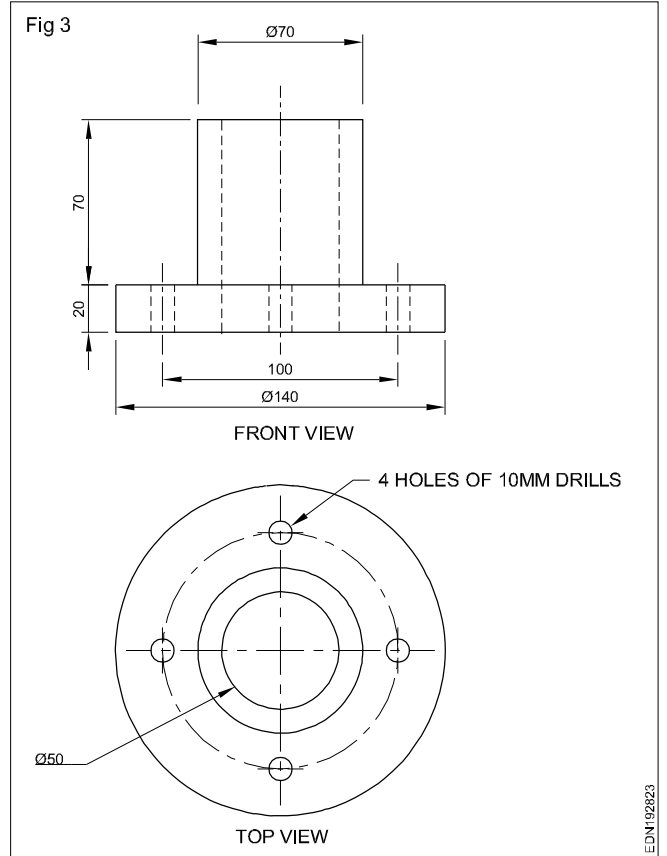
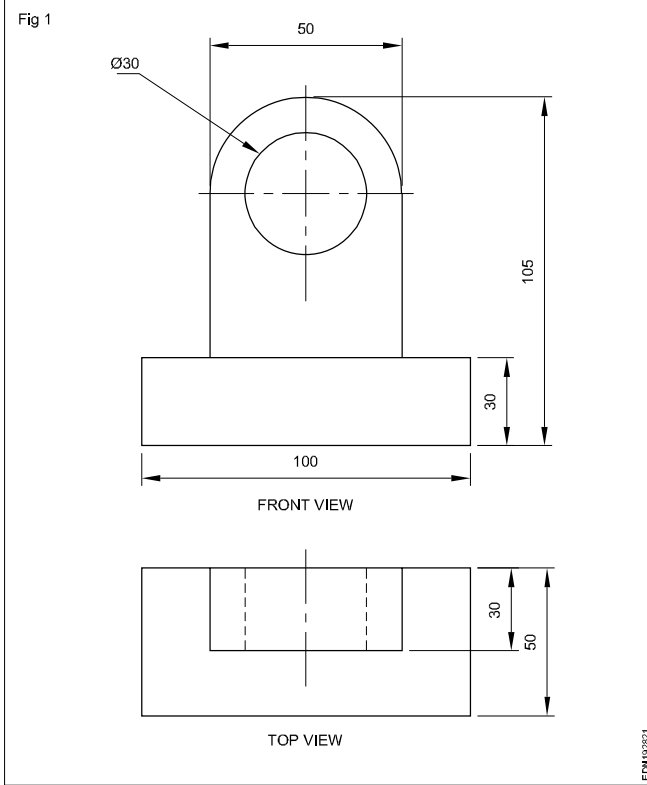

**Symbolic representation - different symbols used in the trades - Fastener (bolts, nuts and rivets)**

**Introduction**

Conventions are the graphical symbols used while making drawings to indicate

- 1 Materials
- 2 Equipments/Instruments/Engineering Components

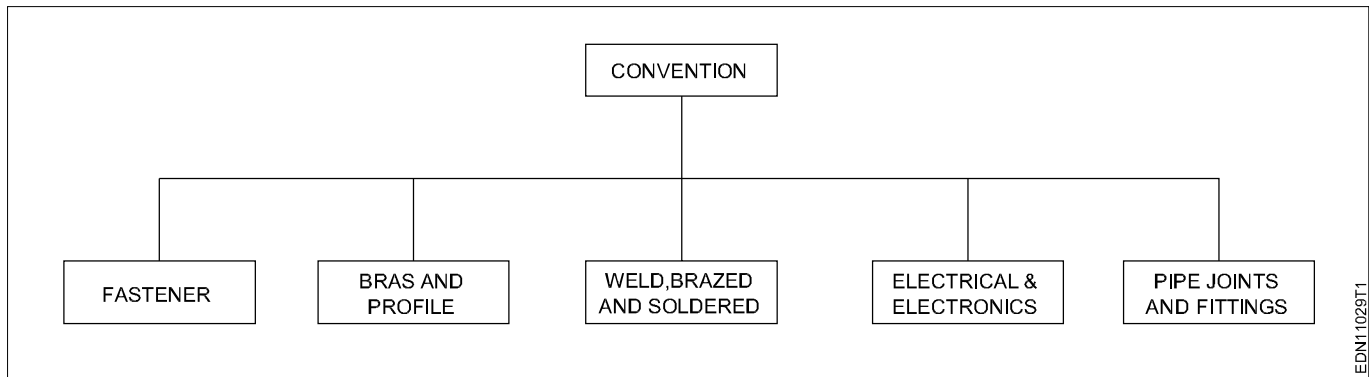



EDN11029T1

- 1 Fasteners (Rivets, Bolts and Nuts)
- 2 Bars and Profile section
- 3 Weld, Brazed and soldering joints
- 4 Electrical and Electronic elements
- 5 Piping joints and Fittings

**Fasteners (bolts, nuts and rivets)**

Grade Identification Marking	Material
	Carbon Steel Carbon Steel Carbon Steel
	Carbon Steel Quenched & Tempered
	Atmospheric Corrosion Resistant Steel, Quenched & Tempered
	Carbon Steel, Quenched & Tempered



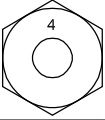
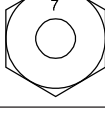
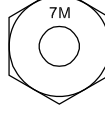

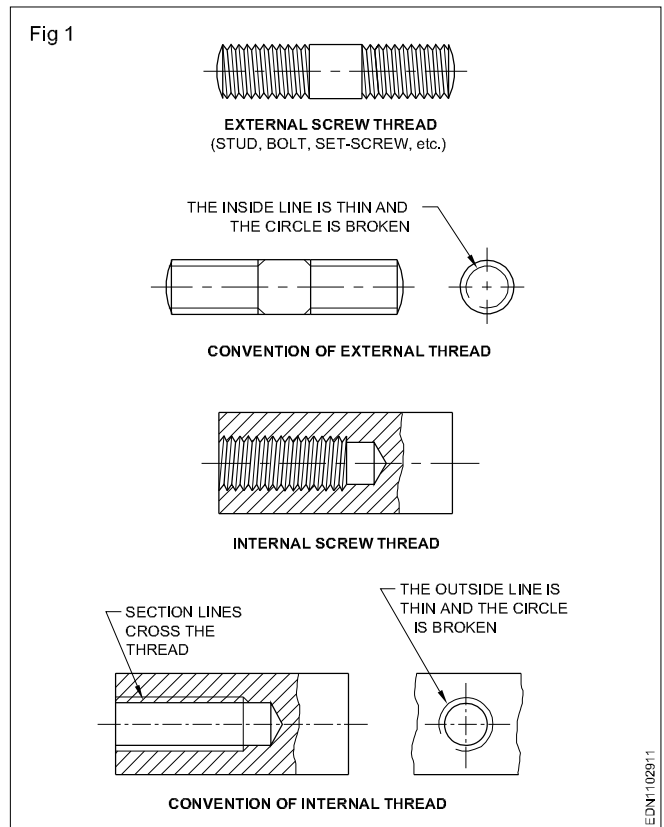
Grade Identification Marking	Material
	Carbon Steel Quenched & Tempered
	Atmospheric Corrosion Resistant Steel, Quenched & Tempered
	Carbon Steel
	Medium Carbon Steel





Grade Identification Marking	Material
	Medium Carbon Steel Quenched & Tempered
	Medium Carbon Steel Quenched & Tempered
	Medium Carbon Steel Quenched & Tempered
	Medium Carbon Steel Quenched & Tempered
	Medium Carbon Steel Quenched & Tempered



### Rivet Symbol

- In case of large drawings where no. of rivets are used, it is not necessary to draw all rivets.
- For this, gauge lines are drawn and location of rivets are shown by line symbol as per I.S.I.

SI.No	Object	Symbol
1	Shop SNAP Headed rivets	
2	Shop CSK (Near side) rivets	
3	Shop CSK (Far side) rivets	
4	Shop CSK (Both side) rivets	
5	Site SNAP Headed rivets	

SI.No	Object	Symbol
6	Site CSK (Near side) rivets	
7	Site CSK (Far side) rivets	
8	Site CSK (Both side) rivets	
9	Open Hole	

## Rivet symbols

Because many engineering structures are too large to be built in the shop, they are built in the largest units possible and then are transported to the desired location. Trusses are common examples. The rivets driven in the shop are called shop rivets, and those driven on the job are called field rivets.

Fig 2

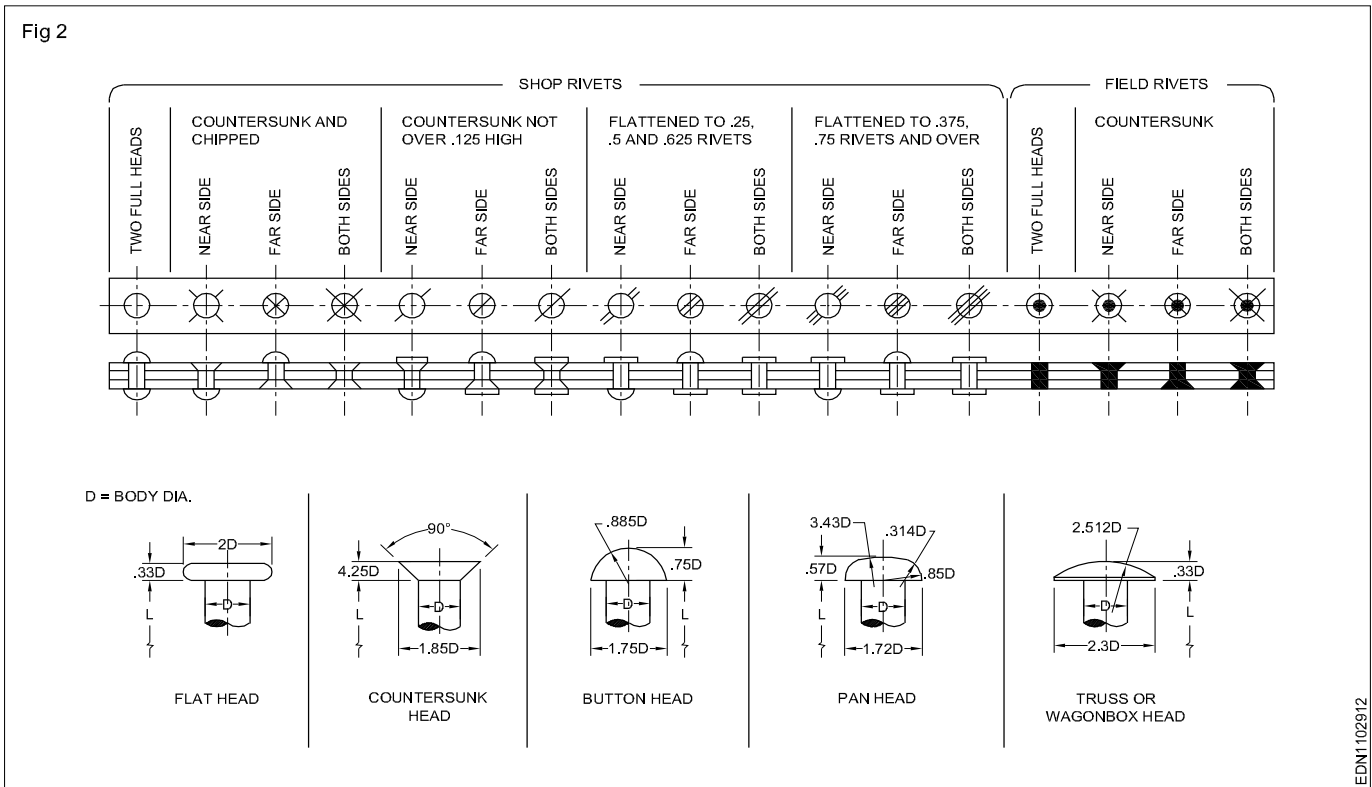

EDN1102912

RIVETED JOINTS CONVENTIONS		
HOLE AND RIVET	SYMBOL FOR HOLE AND RIVET	
	AXIAL VIEW	LATERAL VIEW
DRILLED IN THE WORKSHOP		
DRILLED ON SITE		
FITTED IN THE WORKSHOP		
FITTED ON SITE		
DRILLED AND FITTED ON SITE		



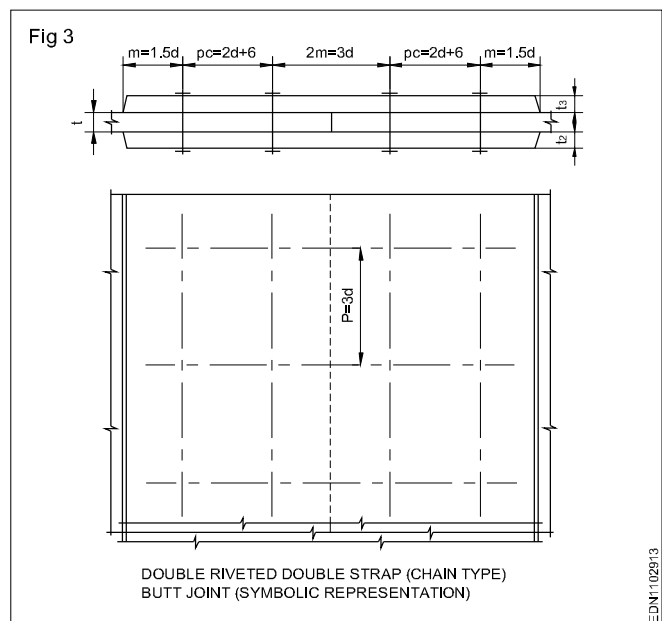

EDN1102914

Fig 3

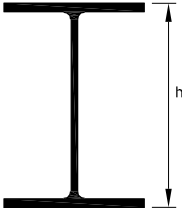
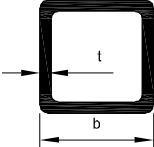
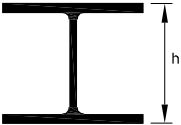
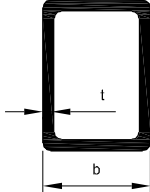
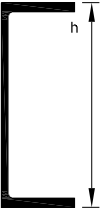
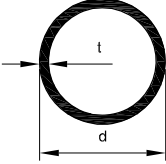
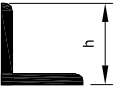

EDN1102913

Symbolic representation of bars and profile sections

①		RECTANGULAR BARS	⑥		UNEQUAL ANGLE
②		I SECTION	⑦		SQUARE TUBES
③		H SECTION	⑧		RECTANGULAR TUBES
④		CHANNEL	⑨		CIRCULAR TUBES
⑤		EQUAL ANGLE	⑩		U SECTIONS

EDN1103011

**Symbolic representation of weld, brazed and soldered joints**

**Convention used for Welded joints**

S.no	Designation	Illustration	Symbol
1	Fillet		
2	Square butt		
3	Single V-butt		
4	Double V-butt		
5	Single U-butt		
6	Double U-butt		
7	Single bevel butt		
8	Double bevel butt		
9	Single J-butt		
10	Double J-butt		
11	Stud		
12	Bead edge or seal		
13	Sealing run		
14	Spot		
15	Seam		
16	Stitch		
17	Plug weld		

**1 Symbolic representation of supplementary welding symbols**

Fig 1

SHAPE OF WELD SURFACE	SYMBOL
1) FLUSH SURFACE	
2) CONVEX SURFACE	
3) CONCAVE SURFACE	

SUPPLEMENTARY WELDING SYMBOLS



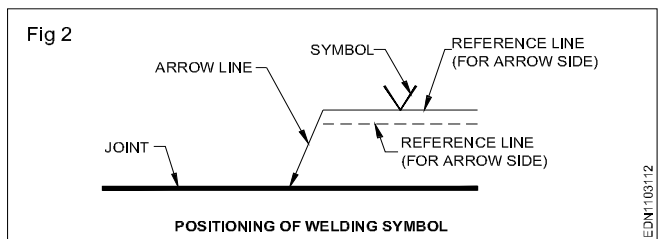

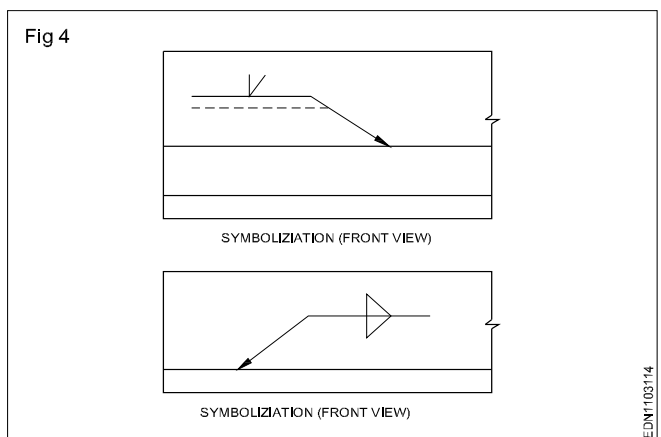
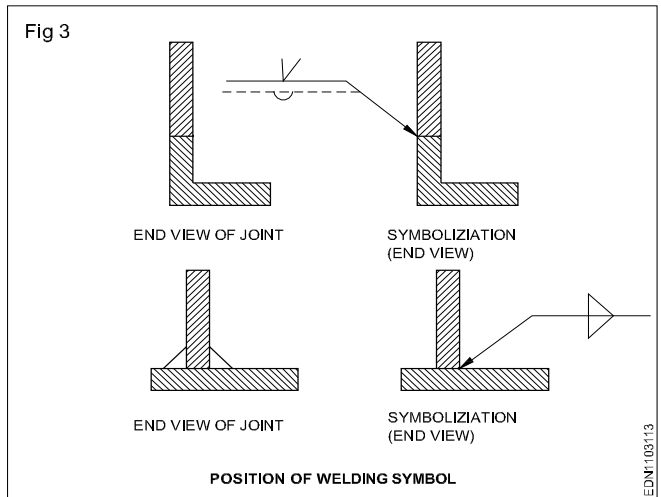

**2 Symbolic representation of Positioning of welding symbols**



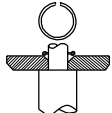
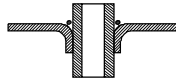

**3 Symbolic representation of End view of joint, its symbolization and front view of its symbolization**



#### 4 Brazed and soldered joints

SHEET METAL	SOLID JOINTS	TUBE JOINTS
 STRAPPED LAP		 FLANGED T
 SIMPLE LAP		 END CAP
 JOGGLE LAP		
 CORNER		
 FLANGED T		
 BUTTED FLANGE		

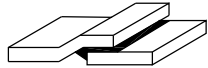
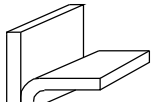
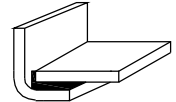

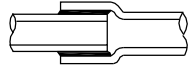

EDN11031T2

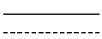

DESIGN OF SOLDERED JOINTS	
 FLANGED BUTT	 FLUSH LAP
 FLANGED EDGE	 FLANGED BOTTOM
 INTERLOCK	 PIPE JOINT

EDN11031T3

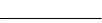
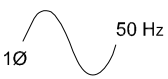
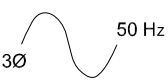
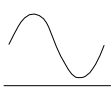
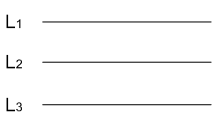
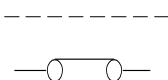

**Symbolic representation of electrical and electronic elements**

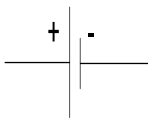
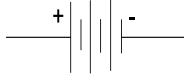
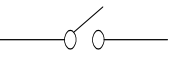
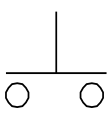
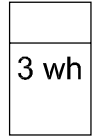

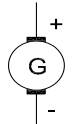
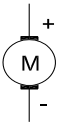

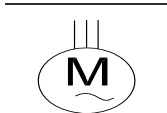
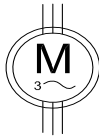
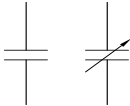
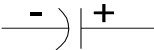
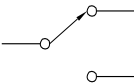
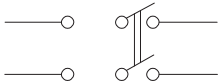
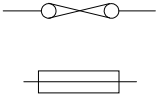
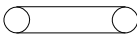

**Conventions used for electrical and electronic elements**



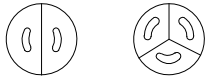
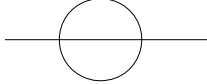
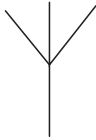

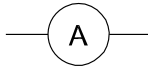
S.No.	Particulars	Symbols
1	D.C.	
2	A.C.	
3	Positive	
4	Negative	
5	Single Phase A.C. 50 Hz	
6	Three Phase A.C., 50 Hz	
7	A.C. / D.C.	
8	3-Phase line	
9	Neutral line	
10	Earth	

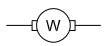
S.No.	Particulars	Symbols
11	Cell	
12	Battery	
13	Single pole single throw switch	
14	Push-button switch	
15	Energy meter	
16	Alternator	
17	Generator	
18	D.C. Motor	

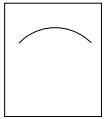
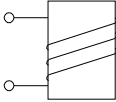
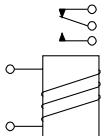

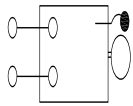

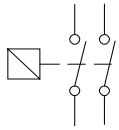
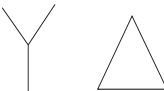
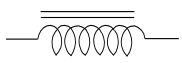

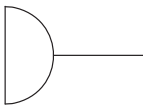
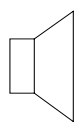
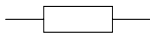
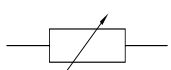
S.No.	Particulars	Symbols
19	A.C.Motor Single phase	
20	3-phase squirrel cage motor	
21	3-phase slip ring motor	
22	Capacitor: Fixed, variable	
23	Electrolytic Capacitor	
24	Two-way switch	
25	D.P.D.T. Switch	
26	Fuse: ordinary cartridge	
27	Link	
28	Socket 2 pin, 3 pin	

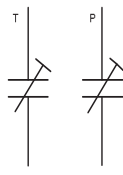
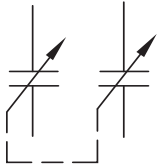
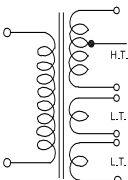
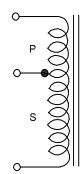
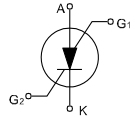
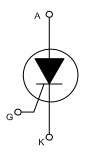
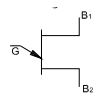
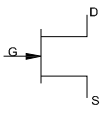
S.No.	Particulars	Symbols
29	Ceiling Rose 2-pin, 3-pin	
30	Over head line	
31	Aerial	
32	Voltmeter	
33	Ammeter	
34	Ohm Meter	
35	Watt Meter	
36	Lamp	
37	Fan regulator	
38	Electro Magnet	
39	Relay	

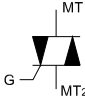
S.No.	Particulars	Symbols
40	Electric bell	
41	Buzzer	
42	Contacts - NO, NC	
43	3-phase contactor	
44	Connections: star, Delta	
45	Choke	
46	Transformers	
47	Carbon microphone	
48	Loudspeaker	
49	Resistor : Fixed	
50	Resistor: variable	

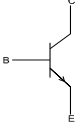
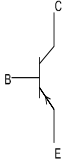
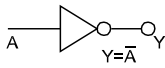
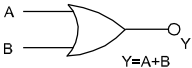
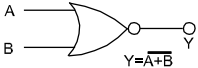
S.No.	Particulars	Symbols
51	Rectifier	
52	Trimmer: Padder	
53	Ganged Capacitor	
54	Main transformer with multiple secondary winding	
55	Auto transformer	
56	Silicon Bilateral switch (SBS)	
57	S.C.R.	
58	U.J.T	
59	F.E.T. N-Channel	

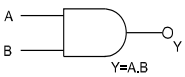
S.No.	Particulars	Symbols
60	F.E.T. P-Channel	
61	TRIAC	
62	DIAC	
63	NPN Transistor	
64	PNP transistor	
65	NOT gate	
66	OR gate	
67	NOR gate	

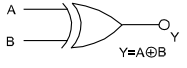
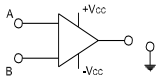
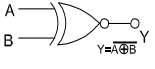
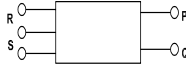
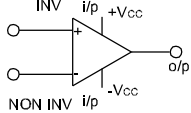
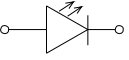
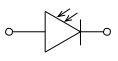
S.No.	Particulars	Symbols
68	AND gate	
69	NAND gate	
70	Ex-OR gate	
71	Operational amplifier	
72	Ex-NOR gate	
73	Flip - flop	
74	Differential Amplifier	
75	Light emitting diode	
76	Photo diode	

**Symbolic representation of piping joints and fittings**

**Isometric and orthographic symbols for pipe fittings**











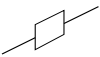



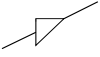





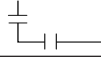
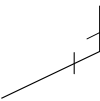
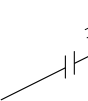

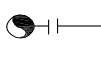
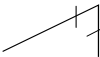

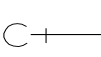
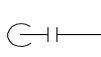



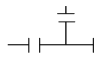
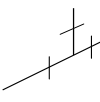
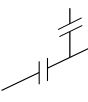
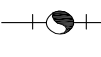
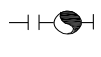
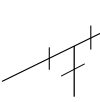

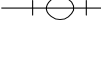
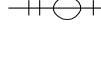
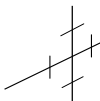
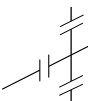
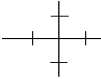
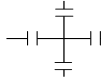
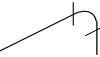





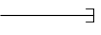
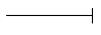
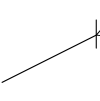



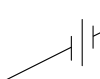

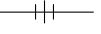



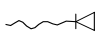



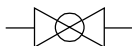
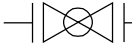

S. No.	Description	Isometric symbol (right face)		Orthographic symbol	
		Screwed	Flanged	Screwed	Flanged
1	Joint/Coupling				
2	Reducer				
3	90° elbow				
	(i) Turned up				
	(ii) Turned down				
4	Tee				
	(i) Turned up				
	(ii) Turned down				
5	Cross				
6	Bend				
7	Plug (female)/(dead end)				
8	Plug (male)				
9	Union				
10	Hose nipple				

Image	Valves	Butt weld Symbol	Flanged Symbol
	Gate		
	Globe		
	Ball		
	Plug		
	Butterfly		
	Needle		

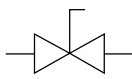
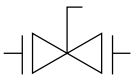
**Projections - concept of axes plane and quadrant**

Graphics are preferred by engineer's and craftsman to communicate their ideas. When graphics are used for communication it is called graphical language. Those who do not have the knowledge of this language are professionally illiterate.

The saying that "A picture is worth a thousand words" is very much relevant in technical work.

An engineering drawing conveys many different types of information of which the most important thing is the shape of the object. Fig 1 shows a sample drawing. In this drawing the shape of the part is represented by three views.

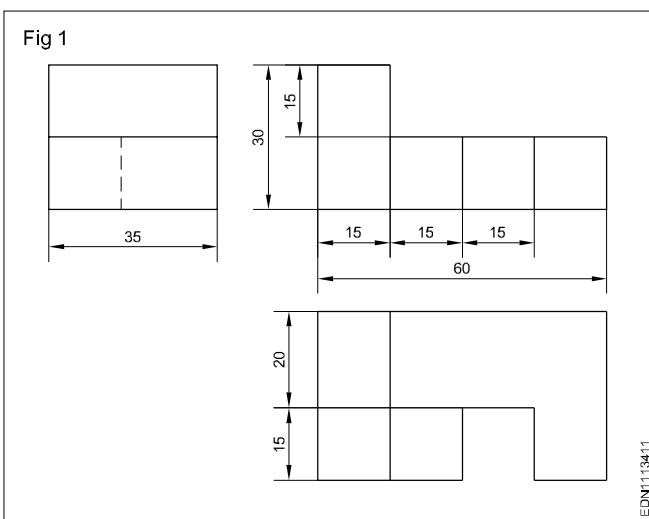

For an untrained person it will be very difficult to conceive the shape of the object from the above drawing.

But in Fig 2, the same object is shown pictorially in a different way and the shape is easily understood even by a layman.

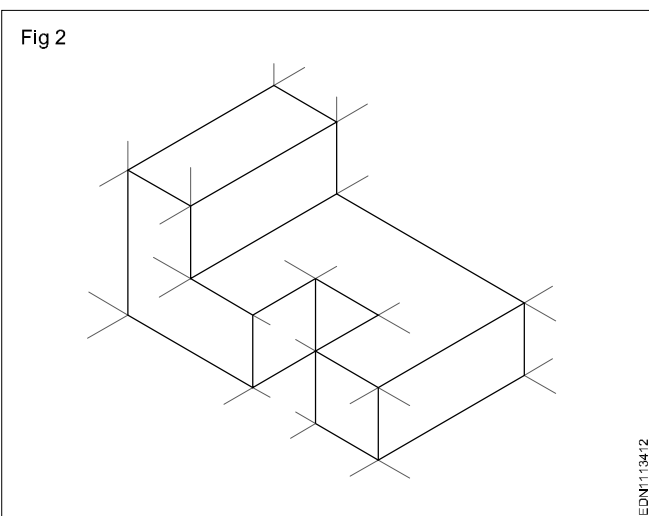

From Fig 1 & 2, it is clear that there are different ways of describing the shape of a part on a paper. Figure 1 is called as Multiview drawing or Orthographic drawing and the method adopted in figure 2 is called pictorial drawing. The different views in a multiview drawing are called as 'Orthographic views' or Orthographic projections.

To describe the shape of a part in engineering drawings, multiview or orthographic view method is preferred as only Orthographic view can convey the true shape of the object. Whereas in pictorial drawing through this shape is easily understood and it is distorted. To emphasise this point, see Fig 3, wherein a cube with a circular hole is represented pictorially. We know that all corners of the cube are of 90°. But in the pictorial drawing in Fig 3, the same 90° is represented at some places by acute angles and at some other places by obtuse angles.

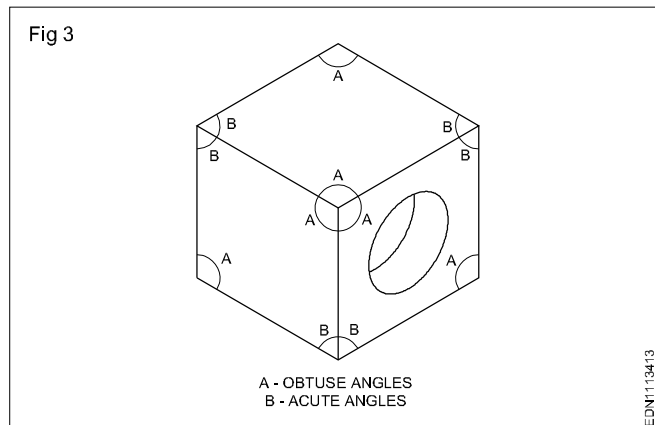

**Projection:** Projection is commonly used term in draughtsman's vocabulary. In the context of engineering drawing, projectors means image and it is comparable to the image formed on the retina of the eyes. (Projection can also be compared to the image of the object on the screen, where the film is projected (by the cinema projector) by the light rays.

Projection or images can also be formed in between the eyes and the object by keeping a transparent plane. (Fig4)

In this figure 4 the rays from the object converge to the eyes and this image (Projection) is smaller than the object. However if the rays are parallel as in the case of rays coming from the sun, the image (Projection) will be of the same size as that of the objects. Such a projection is called orthographic projection. The parallel lines/rays drawn from the object are called projectors and the plane on which image is formed is called plane of projection. In orthographic projection, the projectors are perpendicular to the plane of projection. (Fig 5)

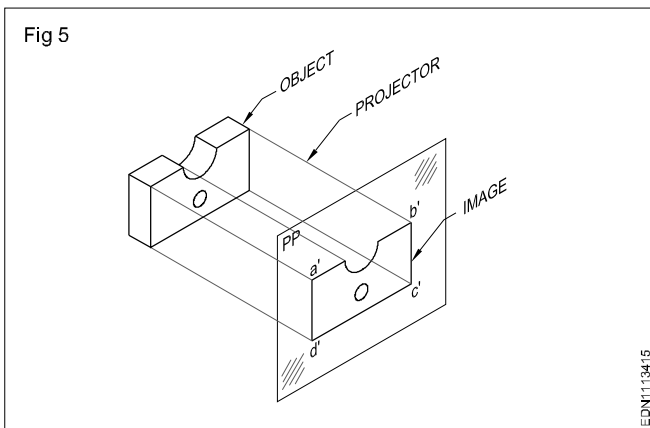
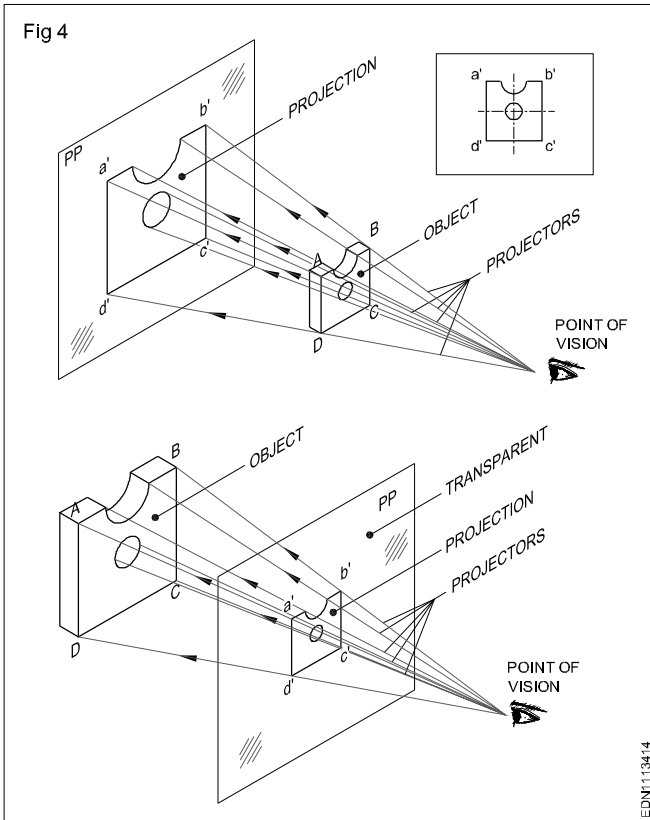

**Orthographic projection:** The term orthographic is projection derived from the words, Ortho means straight or at right angles and graphic means written or drawn. The projection comes from the Old Latin words PRO means forward and Section means to throw. The orthographic projection literally means "Throw to forward", "drawn at right angles" to the planes of projection.

An orthographic system of projection is the method of representing the exact shape and size of a three dimensional object on a drawing sheet or any other plain surface such as drawing board.

A single orthographic view of an object will show only two of its three dimensions. The view in figure 6 shows only the length and height of the object only.

Therefore, it becomes necessary to have an additional view to show the missing dimensions (width). Therefore, we have to make two views to represent the three dimensions of an object.

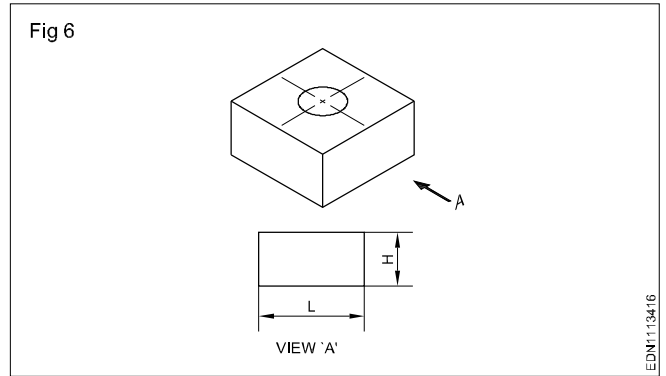

The two views thus required are to be obtained on two different planes which are mutually perpendicular (one HP and one VP) with the object remaining in the same position. The projection or the view obtained on the horizontal plane is called the top view or plan and the view obtained on the vertical plane is called elevation.

First angle and third angle projection: One vertical plane (VP) and one horizontal plane (HP) intersect at right angles to each other. (Fig 7)

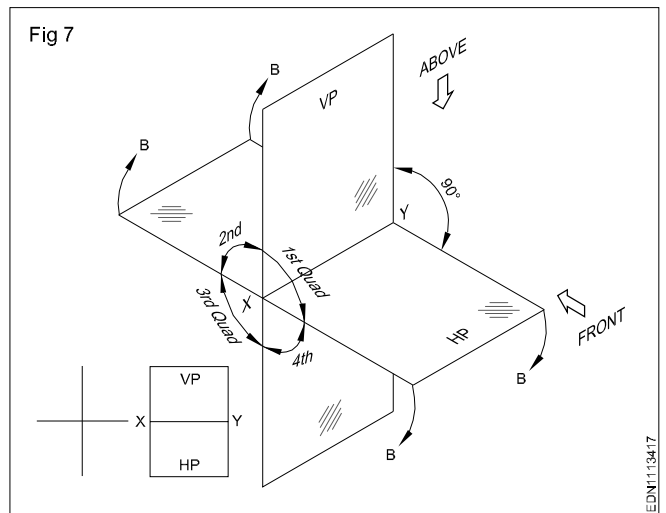

All the four quadrants have one HP and one VP formation. As per convention in mathematics, the quadrants are numbered as 1<sup>st</sup>, 2<sup>nd</sup>, 3<sup>rd</sup> and 4<sup>th</sup>. These four quadrants are called four dihedral angles, namely 1<sup>st</sup> angle, 2<sup>nd</sup> angle, 3<sup>rd</sup> angle and 4<sup>th</sup> angle.

To draw two views of an object, we assume that the object is placed in any one of the quadrant/angles, 1<sup>st</sup> angle & 3<sup>rd</sup> angle Fig 8a, 9a and its plan and elevation projected to the respective planes.

Now to make it possible to draw the two views (Plan & elevation) in one plane i.e the plane of the drawing paper, the horizontal plane is assumed to be unfolded in clockwise direction through 90° Fig 8b & 9b. We proceed this way, when the views are made. When the object is placed in the 2<sup>nd</sup> or fourth quadrant the plan and elevation will get super imposed (one up on the other) Fig 10a & b.

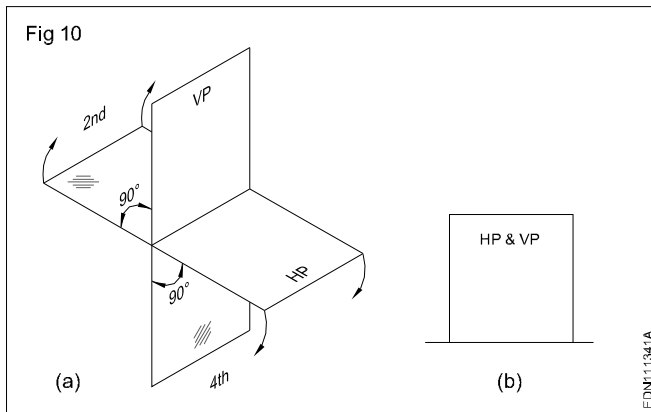
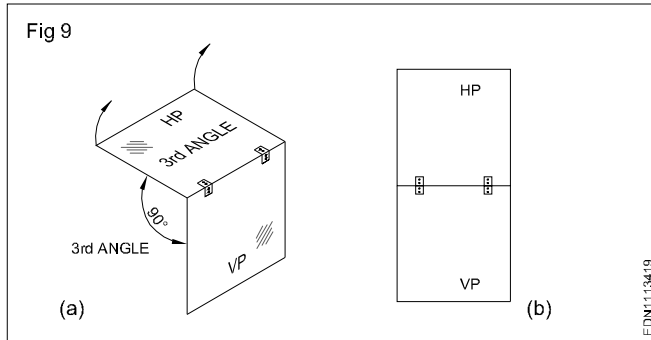
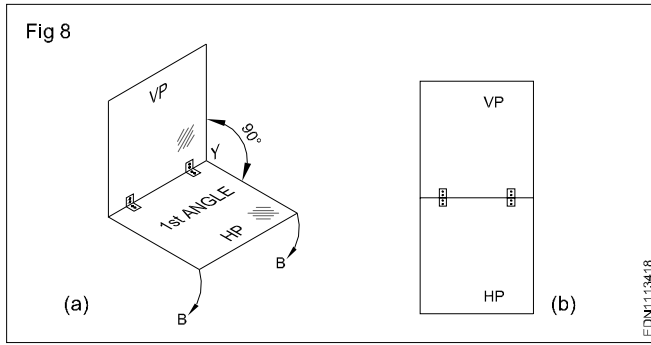

Due to this reason the 2<sup>nd</sup> and 4<sup>th</sup> angle are not used for making engineering drawings as the three dimensions cannot be easily identified. Hence for representing the three dimension of the object, we assume the object is placed either in 1<sup>st</sup> angle and in 3<sup>rd</sup> angle (Fig 11 & 12) respectively

The placement of plan and elevation when the horizontal plane is unfolded will be different in these two systems. It may be observed in Fig 13 that in the first angle projection plan (top views) will be directly below the elevation, whereas in 3<sup>rd</sup> angle projection plan lies directly above the elevation. (Fig 14)

Views can be drawn in any one of these two methods. However Bureau of Indian Standard (BIS) has recommended the first angle method to be used in our country.

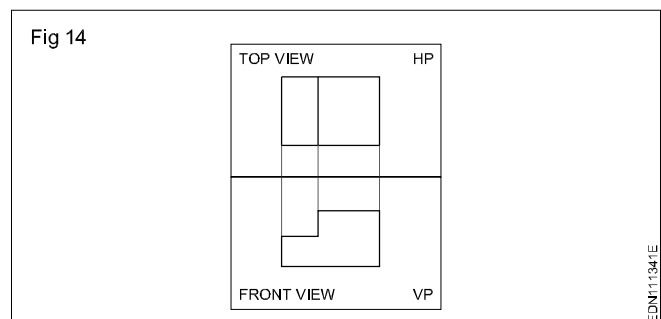
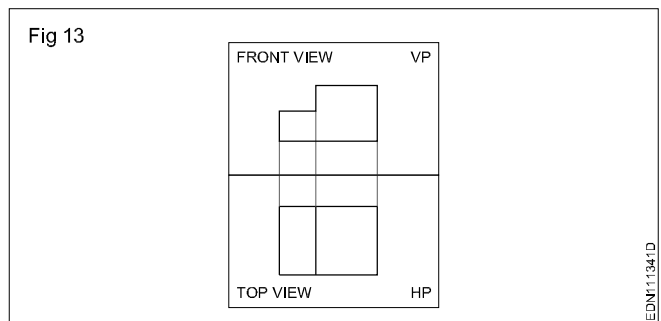
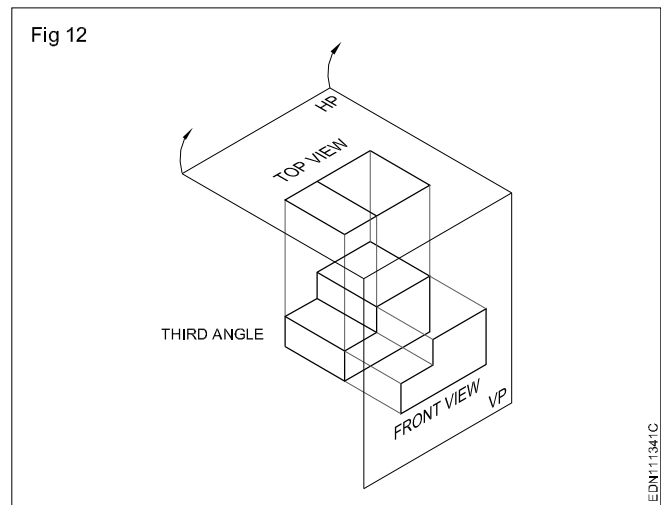
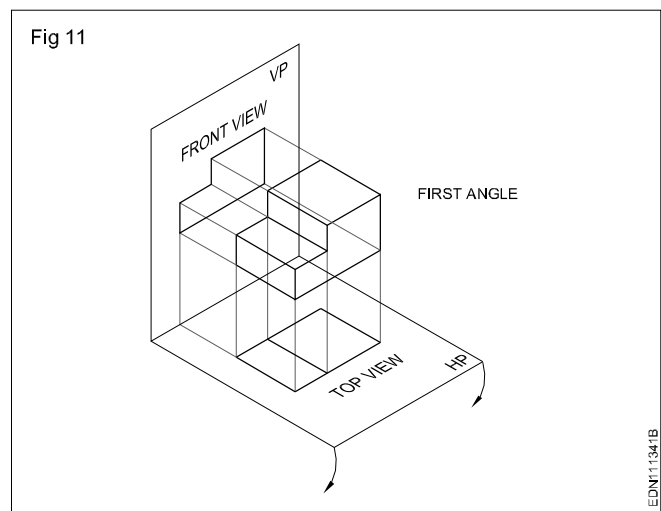



Projections - Orthographic projection

Procedure

Method 1

Draw the orthographic projection (front, top and side views) of the square sheet (40 mm side) kept perpendicular to HP and parallel to VP. (I angle) (Fig 1)

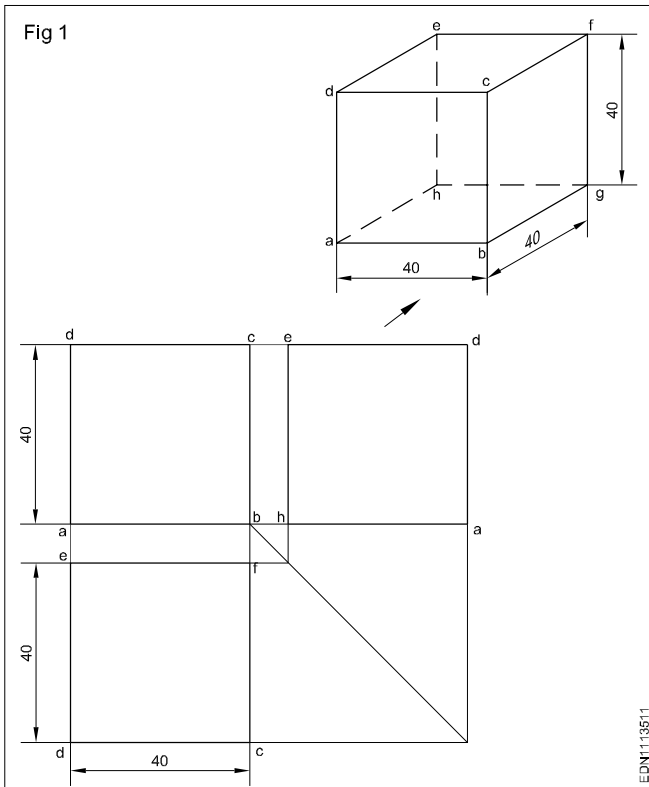

- Draw the xy line.
- Draw the square with its centre 40 mm above the xy line and one edge parallel to xy line.
- Mark the corners of the figure a', b', c' & d'. This will be the front of the square.
- Draw the vertical projectors from a'b' downward beyond the xy line.
- Draw a horizontal line dc at a distance of 20 mm below the xy line. Line dc will be the plan.
- Draw a X'Y' line at a convenient distance from b'c', intersecting the xy line at '0'.
- Project the top to the X Y line meeting at e.
- By arc method transfer Oe to xy and mark the point 'f' at a'' and d'' respectively. Now the line a''d'' is the side view.

Method 2 : Rectangular prism

Draw the Top, Front and side views of the rectangular prism of base 30 x 20 mm and height 40 mm. (Fig 2A)

In this exercise the faces of prism are parallel to the planes of projection. Therefore all the lines orthographic projection are vertical and horizontal lines only.

Visualise the shape of the object and imagine the shape description of views. Surface ABCD (Fig 2B) only visible from the elevation. At the same time all the four sides of ABCD are isometric lines. Therefore in the elevation a rectangle of 40 x 30 mm is seen.

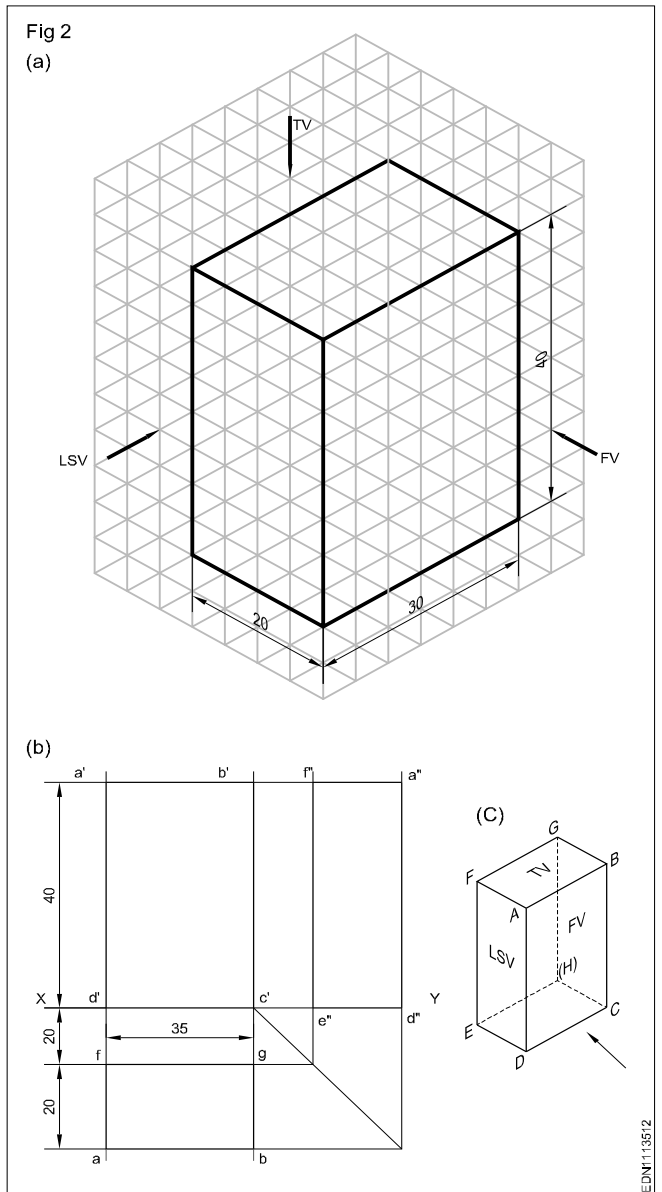

- Draw xy line of convenient length. (Fig 2B)
- Draw a rectangle a'b'c'd' on the xy line. This will be the front view of the prism.
- Project the vertical sides of the front view (a'd' and b'd') downwards beyond xy line.
- Draw a horizontal line fg approximately 20 mm below xy line.

- Draw a rectangle fgba of 35 x 20 mm size. This will be the plan of the prism.
- Project points b' and c' horizontally a convenient length to the right side of the elevation.
- Transfer the width of top view gb by arc and locate points e" d" on the xy line.
- Project e" d" vertically up and locate points f" a" d" e" is the left side view of the prism.

### Method 3 : Hexagonal prism

Draw the three views of the hexagonal prism shown in Fig3A.

From the position described above, it is clear that the hexagonal face of the prism is parallel to AVP. Therefore the end view is a true hexagon and hence this view should be drawn first.

- Draw the side view (hexagonal of side 25 mm) with one side on HP line. (Fig 3B)
- Draw horizontal projectors from side view and complete the front view. (in the front view two lateral faces are visible, but they are fore shortened)

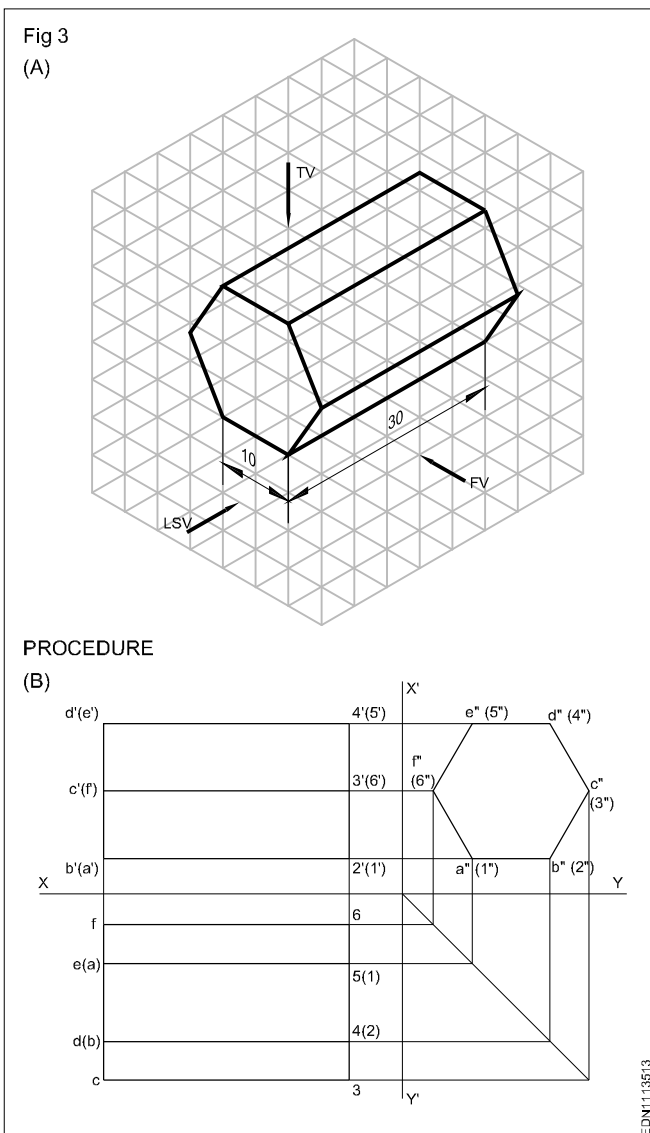

- Draw projectors from elevation and side view and complete the plan.

(Three lateral faces are visible of which one is of true shape and the other two are fore shortened)

### Method 4 : Cylinder

Draw the top, front and side view of a cylinder of diameter 20 mm and length 30 mm. (Fig 4A)

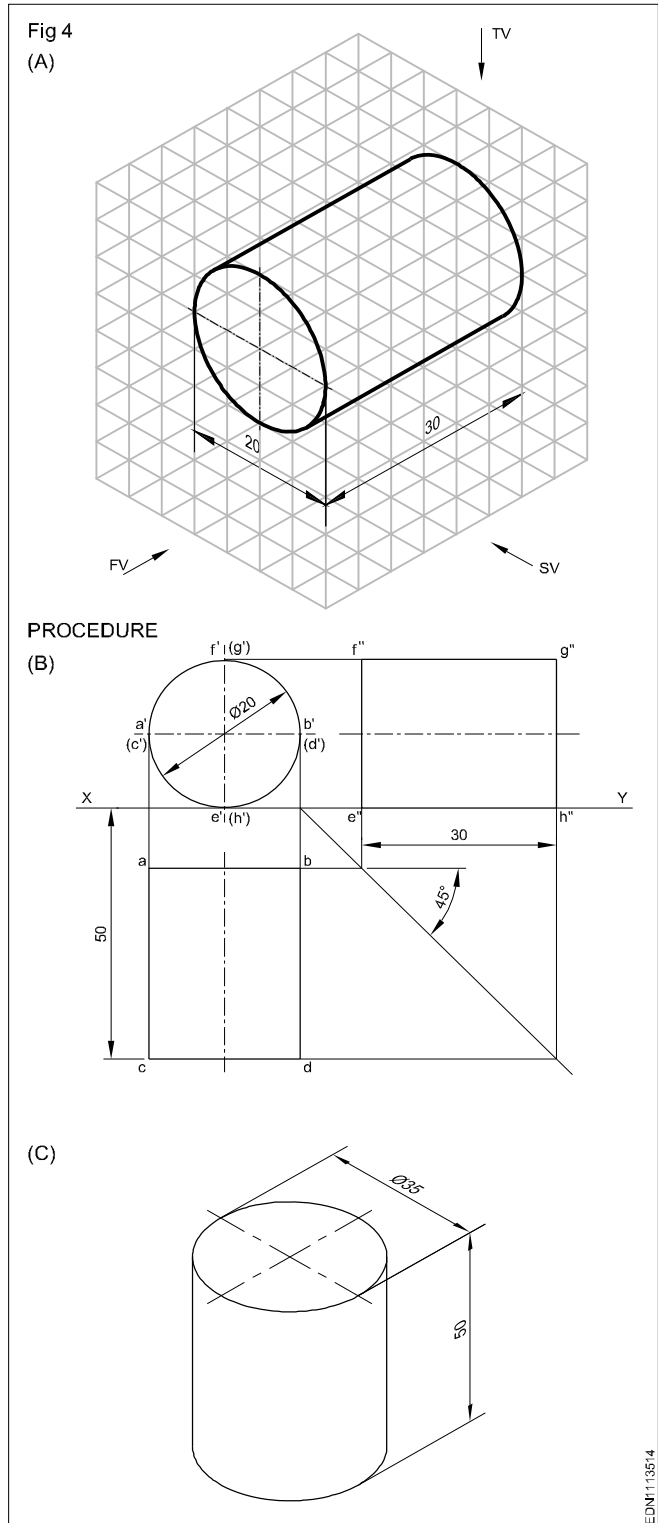

In this problem the circular faces are parallel to VP. Therefore the front is a circle resting on XY line. Plan an end views are rectangles of size 30 mm x 20 mm.

- Draw the circle of diameter 40 mm touching XY line. (Fig4B)
- Draw the plan projecting it from the elevation.
- Draw the end view by drawing projection on it, from the plan and elevation.
- Draw the top, front and side views of a cylinder whose base diameter 35 mm and height 50 mm when its position is as shown in Fig 4C.

**Method 5 : Cone**

Draw the multi-views of the cone shown in the Fig 5A. Follow the procedures of the earlier exercises and draw the multi-views. (Fig 5B)

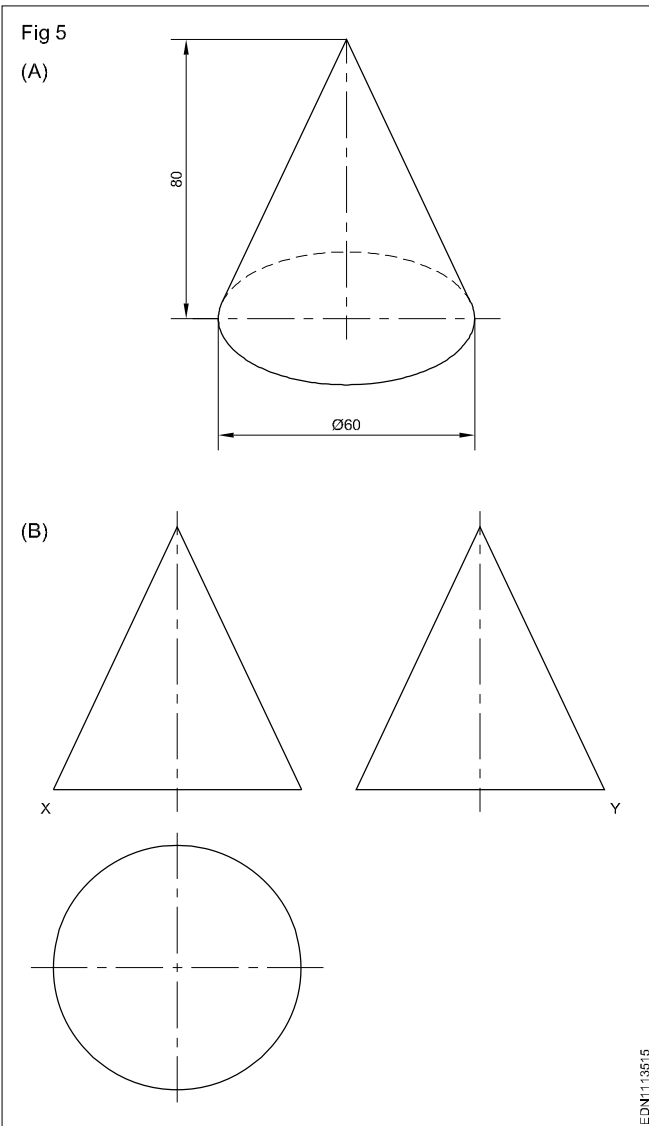

**Method 6 : Regular hexagonal pyramid**

Draw the Orthographic views of a regular hexagonal pyramid of side 20 mm and height 40 mm given its position as below. (Fig 6A)

- standing vertically with its base on HP and one side of the hexagonal base parallel to VP.

The pyramid has 6 triangular faces and one hexagonal base. The top view will show the true shape of the base and other six triangular faces are fore-shortened.

In this front view, three triangular faces are seen and all of them are fore-shortened.

- Mark the centre of hexagon (Point P) and draw lines from P to the six corners of the hexagon. Now this is the required plan. (Fig 6B)
- Project this P from plan upwards and mark P' at a distance of 75 mm from XY line.
- Mark the points f', a'b'c' etc... on XY line by projecting the corresponding points from plan.
- Join the P' with f', a',b',c' etc and complete the required elevation.
- Draw projectors from elevation and plan to complete the required side view.

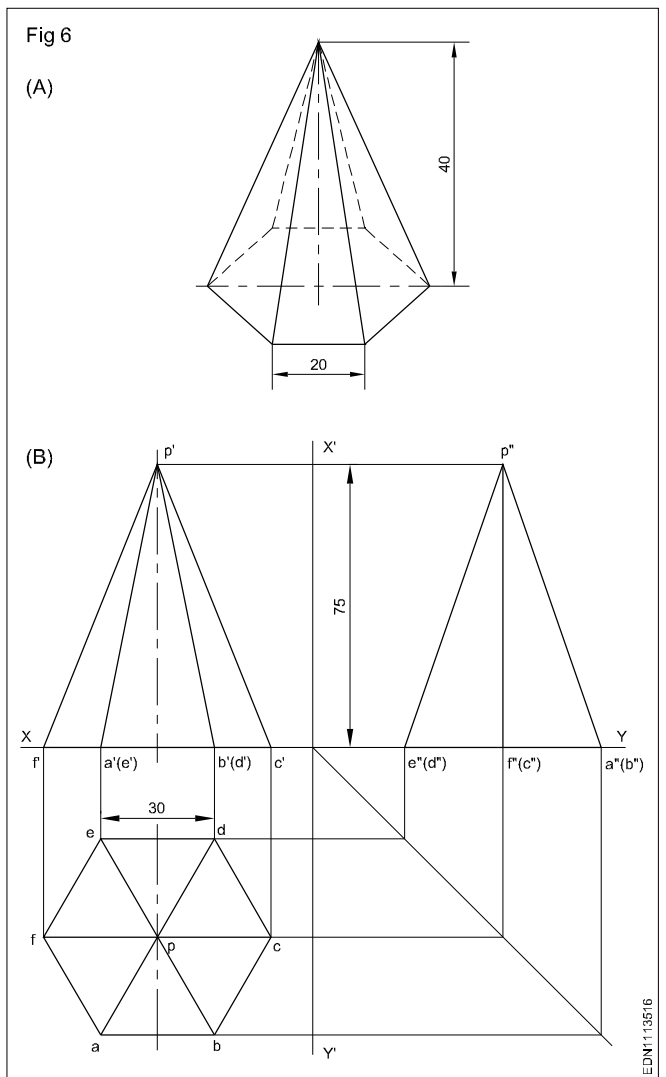

**Method 7**

Identify the surfaces of the block shown in the isometric view with the corresponding multi-views and fill the numericals in the given tabulation column. (Fig 7)

The surfaces are parallel and perpendicular to the plane of projection.

- Study the isometric view and the corresponding multi-views carefully.

- You may observe that the surfaces seen in one view are represented by lines in other two views.
- In this exercise the surface 'A' shown in isometric view is seen as a line in the front elevation and numbered as '5' in the front view of the corresponding multi-views.
- The same surface 'A' in the side view is seen as a line and numbered '6' in the side view of the multi-views.

- Similarly the surface 'A' seen from the top of the isometric views is numbered as '10' in the plan of the multi-views, whereas the full surface area is visible.

When a surface is parallel or perpendicular to the plane of projection vice-versa in a multi-views drawing, full area of the surface will be seen in any one the three views (plan, elevation and side view) and in other two views the corresponding line of the surface will be seen.

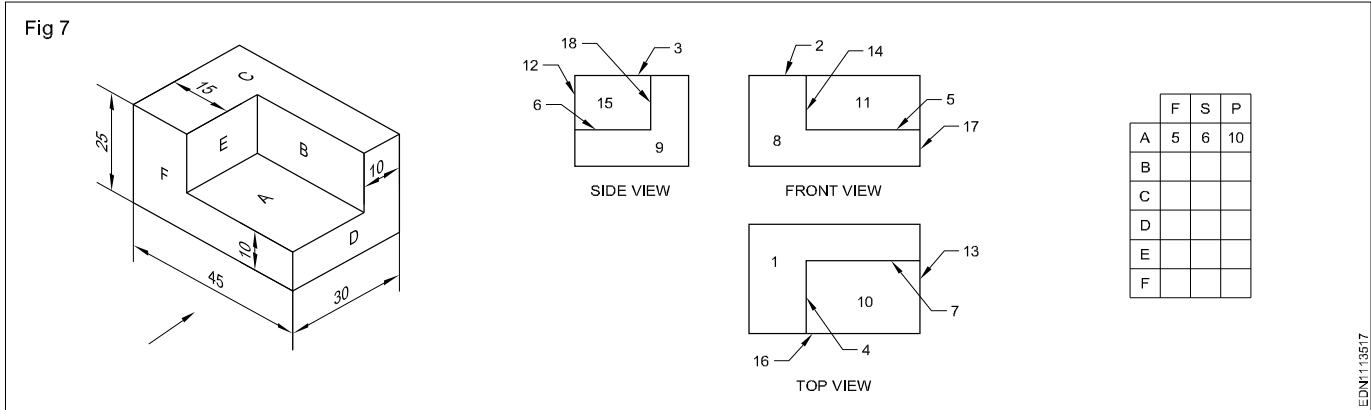

### Method 8

Identify the surfaces of the block with slope cuts shown in isometric view with the corresponding multi-views and fill the tabulation column. (Fig 8)

Surfaces B and F are inclined to HP and parallel to VP.

- You may observe that the surface inclined to one plane is seen in other two views as fore-shortened area of the surface and in other view the corresponding line of the surface is visible.

- In this exercise, the surface 'B' is seen as a surface in front view and top view, numbered in multi-views as 7 & 8 respectively.
- The same surface 'B' in the side view is seen as a line and numbered as 19 in the multi-views which are shown in tabular column. Study the drawing carefully and fill up the other columns.

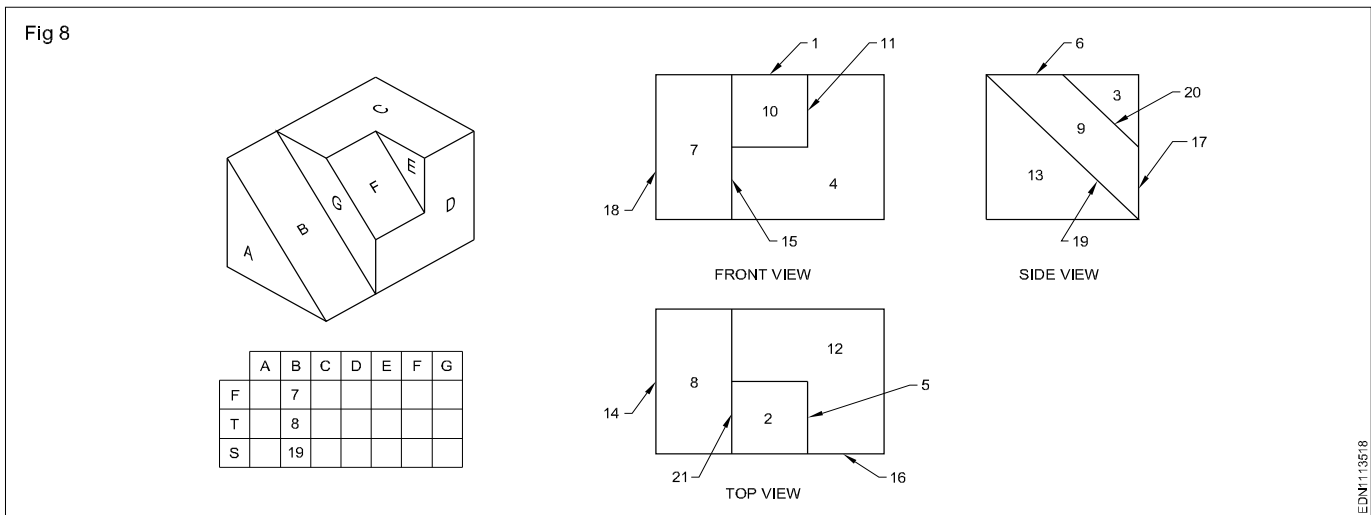

### Method 9 (Fig 9)

Identify the surfaces of the block shown in Isometric view with the corresponding multi-views and fill in the tabulation column. (Fig 9)

The surface is inclined to three planes HP, VP & AVP.

- In this exercise you may observe that the surface 'A' is inclined to all the three planes.
- When you visualise the surface 'A' in the front view of the isometric view, the fore-shortened area of the surface is seen and numbered as 2 in the multi-view.

- Seen from top of the isometric view the fore-shortened area of the surface is seen and numbered as 5 in the top view of the multi-view. Similarly in side view it is numbered as 7 in multi-view.

When a surface of the object is inclined to all the planes, the complete fore-shortened surface will be seen in all the three views.

- Fill the other columns and complete the exercise.

Fig 9

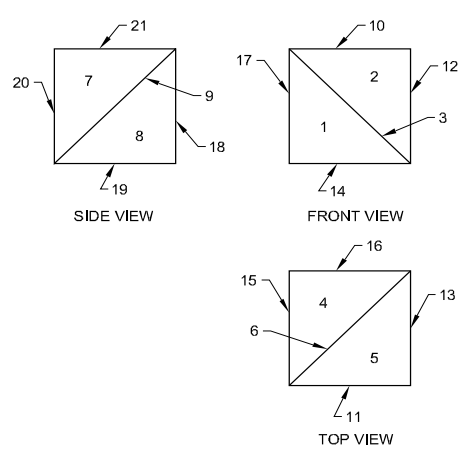
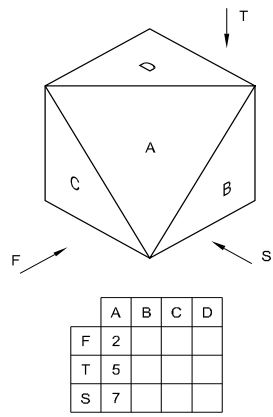

EDN113519

**Method 10**

Draw the isometric view (Fig 10) and also draw the three views in the work book.

Fig 10

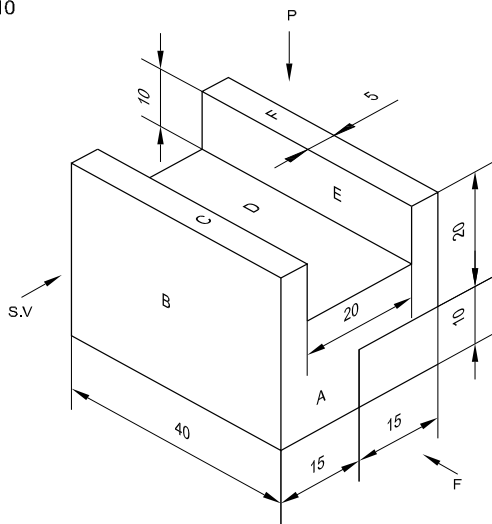

EDN11351A

Orthographic projection shows the shape of a component by drawing number of views each looking at different side of the component.

A minimum of two views are required to represent a component. In order to clarify clearly the internal and external details a minimum of three views are to be drawn. They are:

- Elevation or Front view or Front elevation. (F)
- Plan or Top view. (P)
- Side view or side elevation or end elevation. (S)

In the Fig 10, surface 'A' is only seen when looking at the front of the figure. All the lines in the isometric view are isometric lines. Therefore in the orthographic projection, the front view will be like this. (Fig 11)

In the plan surfaces 'C', 'D' and 'F' are visible and the bottom surface will not be visible. The line joining the two surfaces will not be visible. The line joining the surfaces will appear in the plan by hidden line. (Fig 12)

In the side view surface 'B' is visible and surfaces 'E' and back bottom surfaces are invisible. Due to this reason the

Fig 11

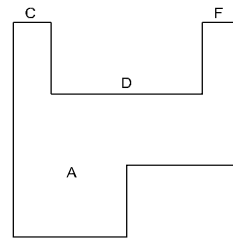

EDN11351B

Fig 12

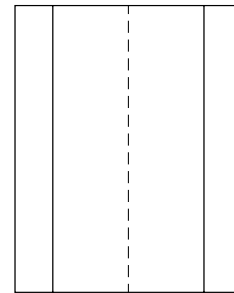

EDN11351C

line joining 'D' and 'E', also the line joining back bottom surfaces are appearing in the side view by hidden line. (Fig 13)

Arrange views as stated earlier with uniform gap between views. (Fig 13)

Fig 13

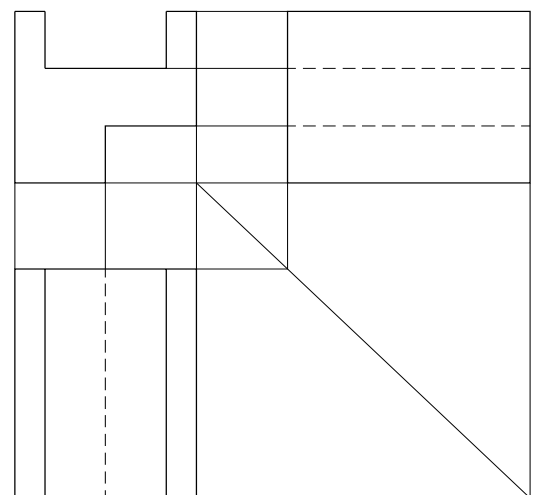

EDN11351D

**Projection - Method of 1<sup>st</sup> angle and 3<sup>rd</sup> angle projections (Definition and difference)**

An orthographic system of projection is the method of representing the exact shape and size of a three dimensional object on a drawing sheet or any other plain surface such as drawing board.

3<sup>rd</sup> Angle projection (Fig 1)

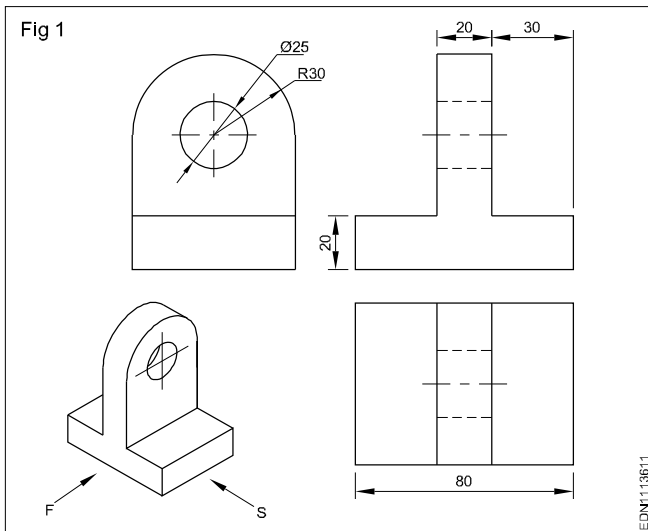

1<sup>st</sup> Angle projection (Fig 2)

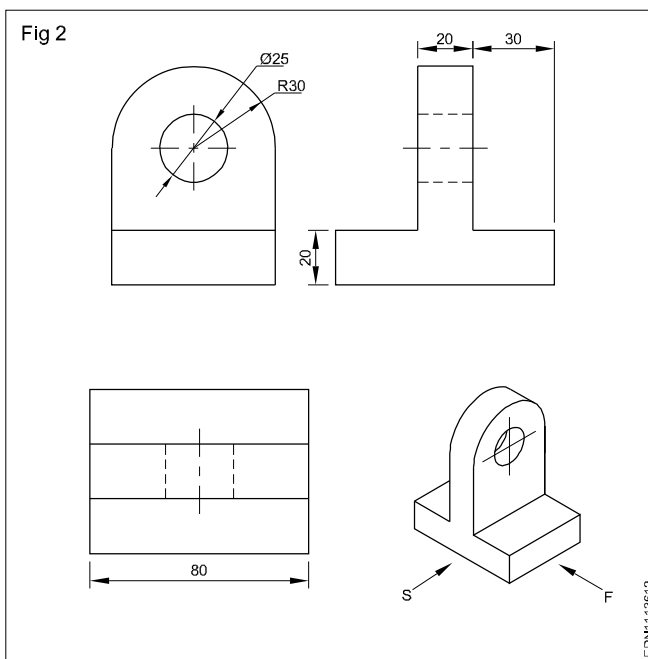

A single orthographic view of an object will show only two of its three dimensions. The view in figure.1 front view shows only the length and height of the object only.

Therefore, it becomes necessary to have an additional views of top and side views to show the missing dimensions (width). Therefore, we have to make two views to represent the three dimensions of an object.

The two views thus required are to be obtained on two different planes which are mutually perpendicular (one HP and one VP) with the object remaining in the same position. The projection or the view obtained on the horizontal plane is called the top view or plan and the view obtained on the vertical plane is called elevation.

First angle and third angle projection: One vertical plane (VP) and one horizontal plane (HP) intersect at right angles to each other. (Fig 3)

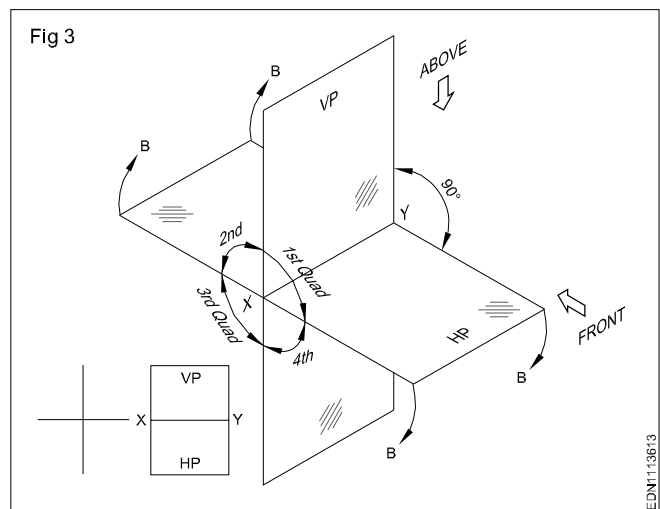

All the four quadrants have one HP and one VP formation. As per convention in mathematics, the quadrants are numbered as 1<sup>st</sup>, 2<sup>nd</sup>, 3<sup>rd</sup> and 4<sup>th</sup>. These four quadrants are called four dihedral angles, namely 1<sup>st</sup> angle, 2<sup>nd</sup> angle, 3<sup>rd</sup> angle and 4<sup>th</sup> angle.

To draw two views of an object, we assume that the object is placed in any one of the quadrant/angles, 1<sup>st</sup> angle & 3<sup>rd</sup> angle (Fig 4a & 5a) and its top and front view projected to the respective planes.

Now to make it possible to draw the two views (Front & Top view) in one plane i.e the plane of the drawing paper, the horizontal plane is assumed to be unfolded in clockwise direction through 90° (Fig 4b & 5b). We proceed this way, when the views are made. When the object is placed in the 2<sup>nd</sup> or fourth quadrant the front and top will get super imposed (one up on the other) (Fig 6a & 6b).

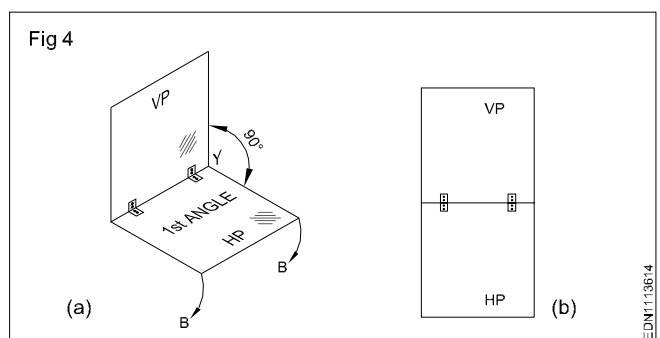

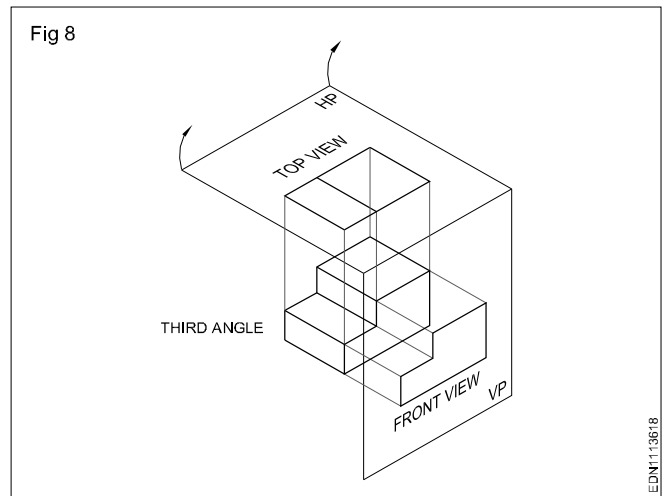
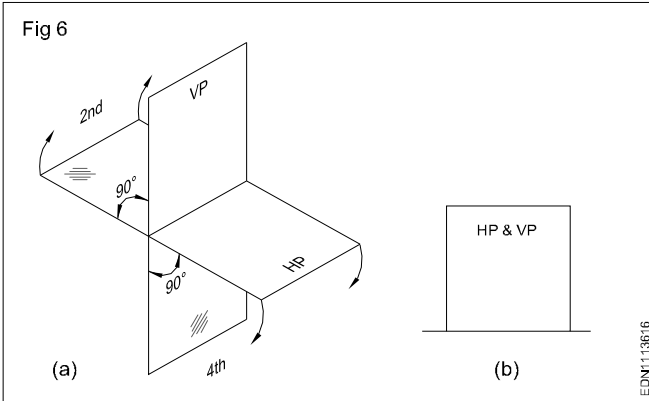
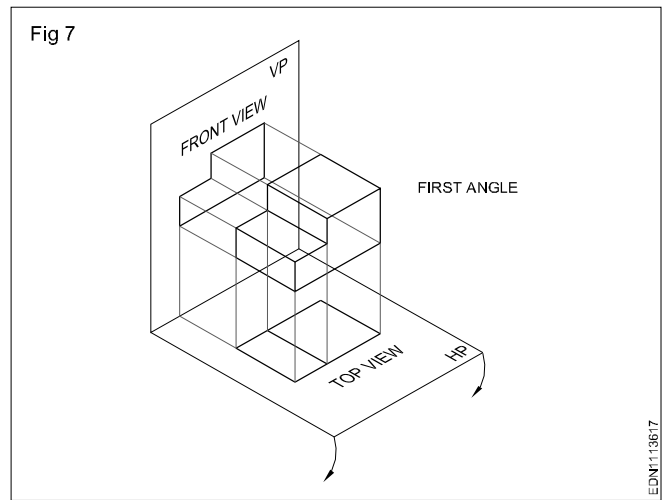
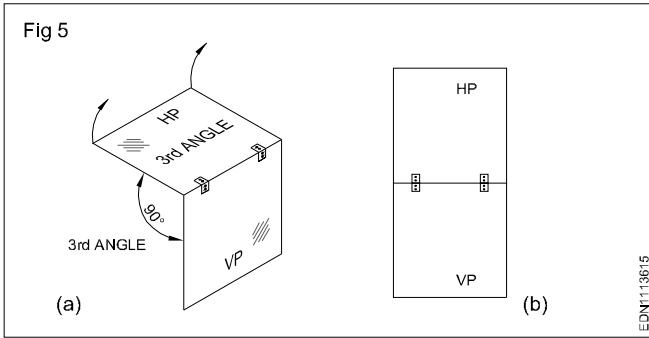

Due to this reason the 2<sup>nd</sup> and 4<sup>th</sup> angle are not used for making engineering drawings as the three dimensions cannot be easily identified. Hence for representing the three dimension of the object, we assume the object is placed either in 1<sup>st</sup> angle and in 3<sup>rd</sup> angle (Fig 7&8) respectively

The placement of front and top views when the horizontal plane is unfolded will be different in these two systems. It may be observed in Fig 8, that in the first angle projection plan (top views) will be directly below the front view, whereas in 3<sup>rd</sup> angle projection top view lies directly above the elevation. (Fig 10)

Views can be drawn in any one of these two methods. However Indian Standard (BIS) has recommended the first angle method to be used in our country.

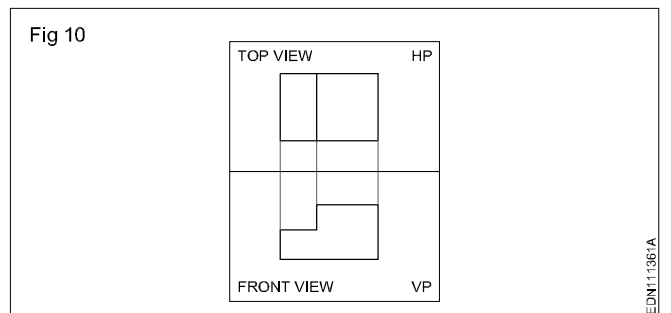
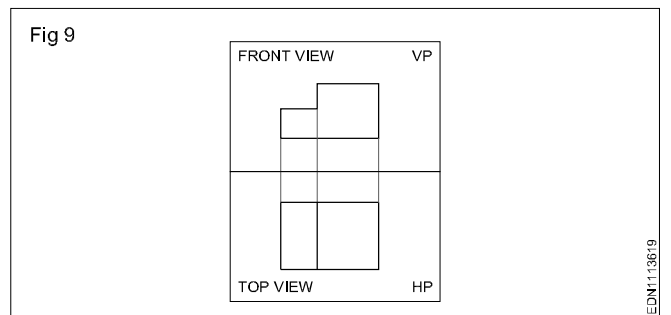

Projection - Symbol of 1<sup>st</sup> angle and 3<sup>rd</sup> angle projection as per IS specification

PROPORTION OF PROJECTION SYMBOLS

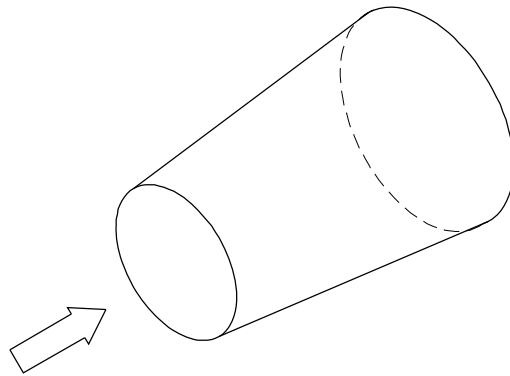

SYMBOL FOR THIRD ANGLE

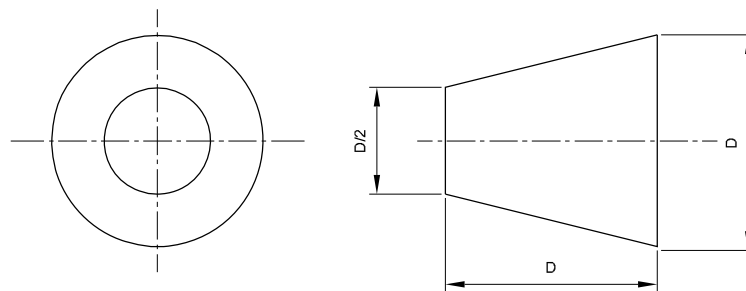

SYMBOL FOR FIRST ANGLE

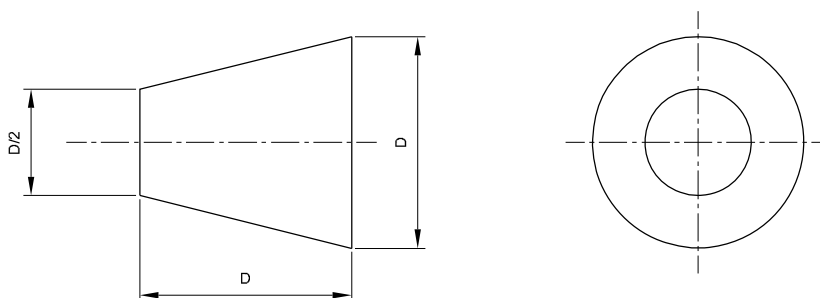

EDN1113611

- 1 a Draw the symbol for 1<sup>st</sup> angle projection as per IS specification, if bigger dia D is 50 mm.  
b Draw the symbol for 3<sup>rd</sup> angle projection as per IS specification, if bigger dia D is 40 mm.
- 2 a Draw the symbol for 1<sup>st</sup> angle projection as per IS specification, if smaller dia D/2 is 20 mm.  
b Draw the symbol for 3<sup>rd</sup> angle projection as per IS specification, if smaller dia D/2 is 15 mm.



Drawing of orthographic projection from isometric projection

Draw Orthographic views in first angle projection

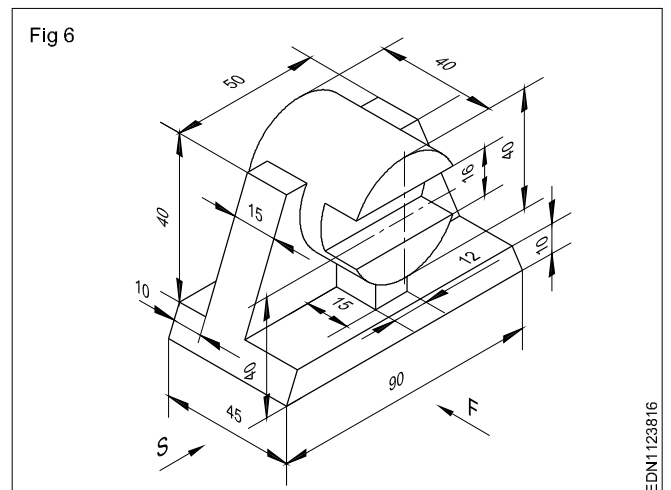
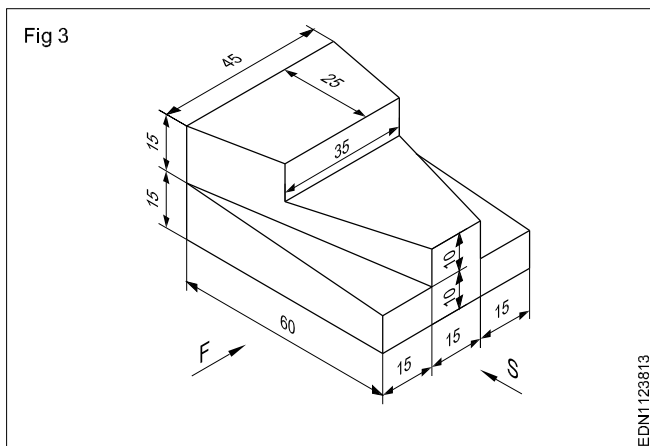
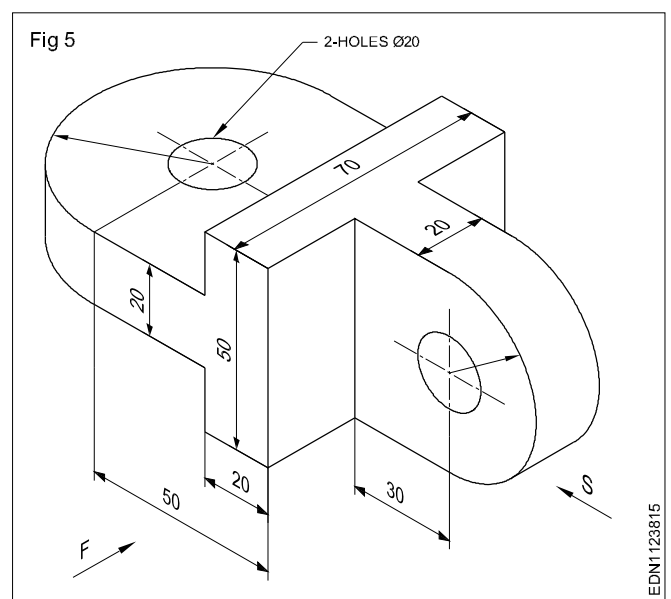
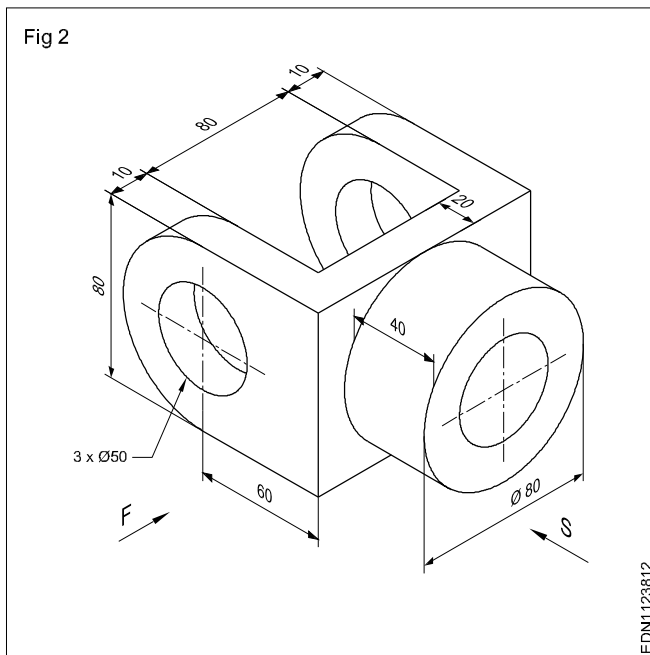
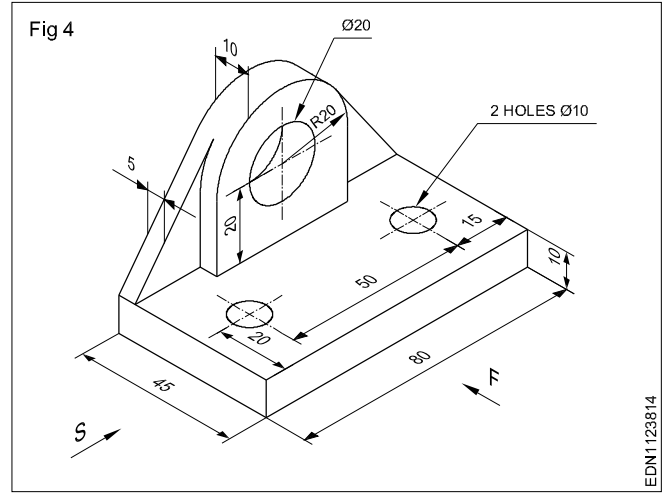
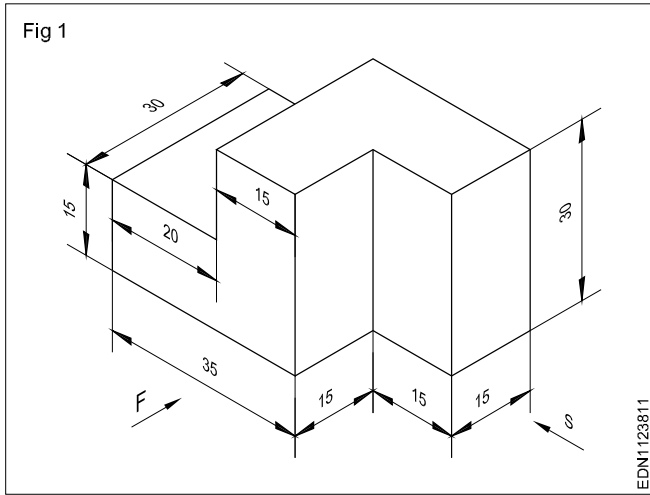

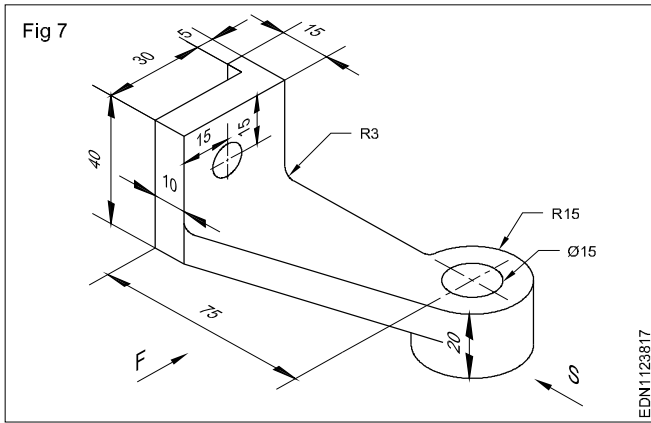

Draw three views of the block both in 1<sup>st</sup> and 3<sup>rd</sup> angle projection.

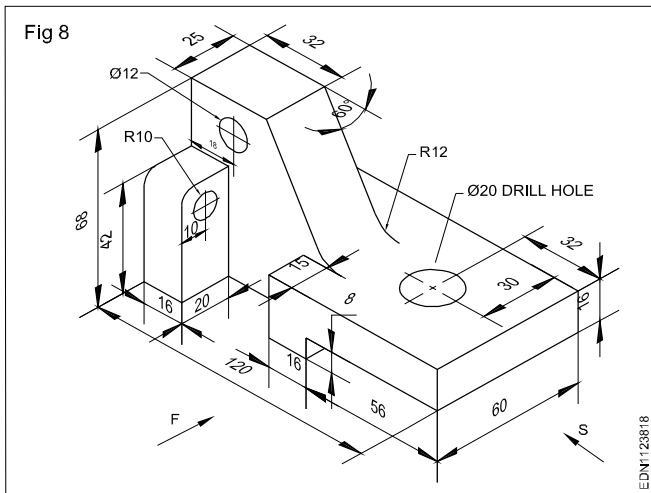

Draw three views of the block in 1<sup>st</sup> angle projection.

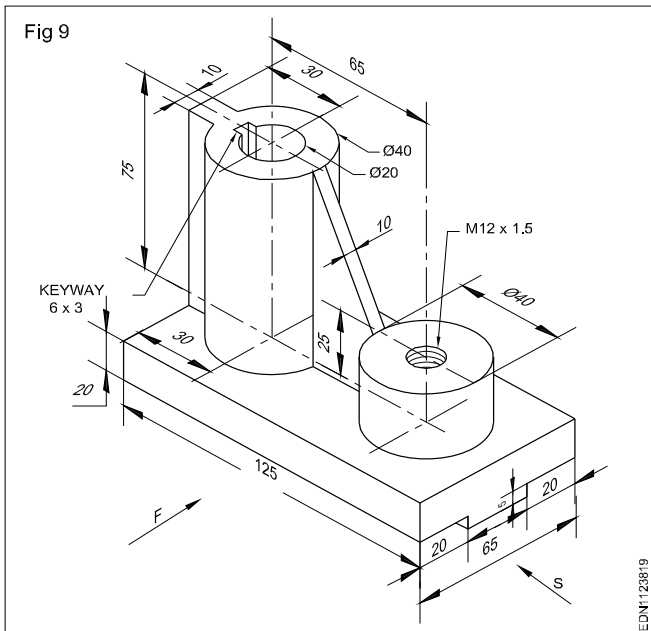

Draw three views of the block in 1<sup>st</sup> angle projection.

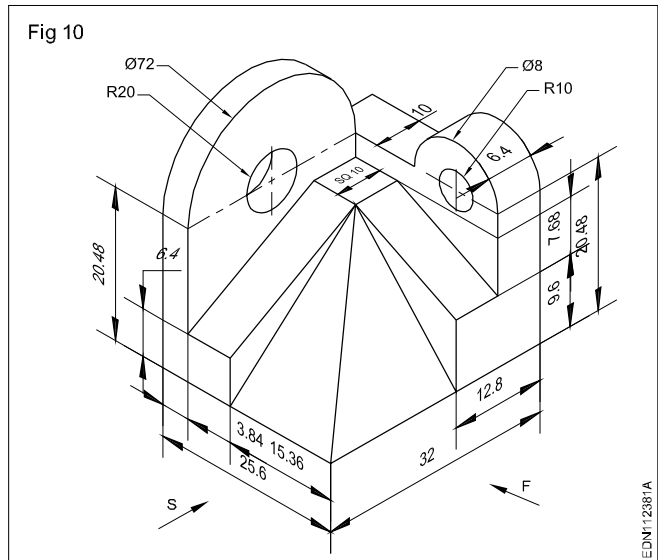

Draw three views of the given block in 3<sup>rd</sup> angle projection.

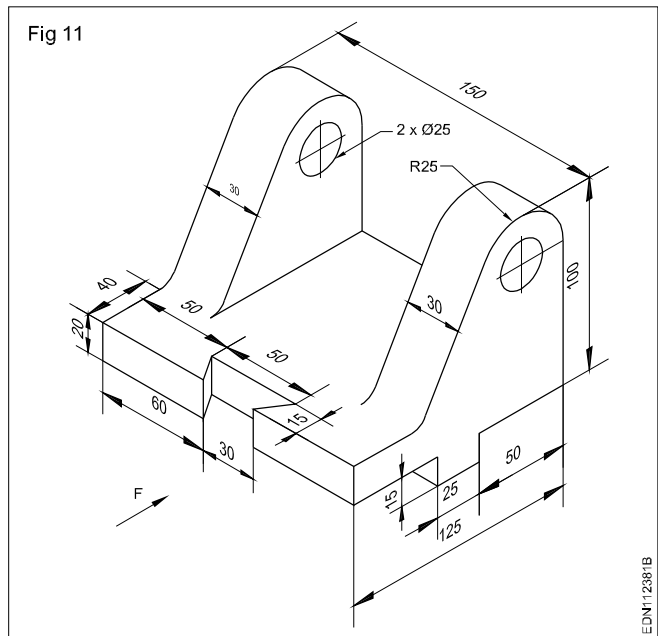

Draw three views of the given block in 3<sup>rd</sup> angle projection.

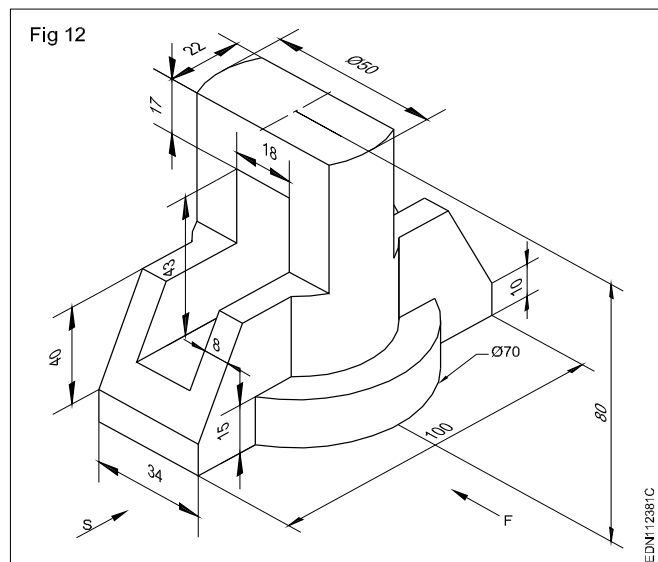

Draw three views of the given block in 1<sup>st</sup> and 3<sup>rd</sup> angle projection.

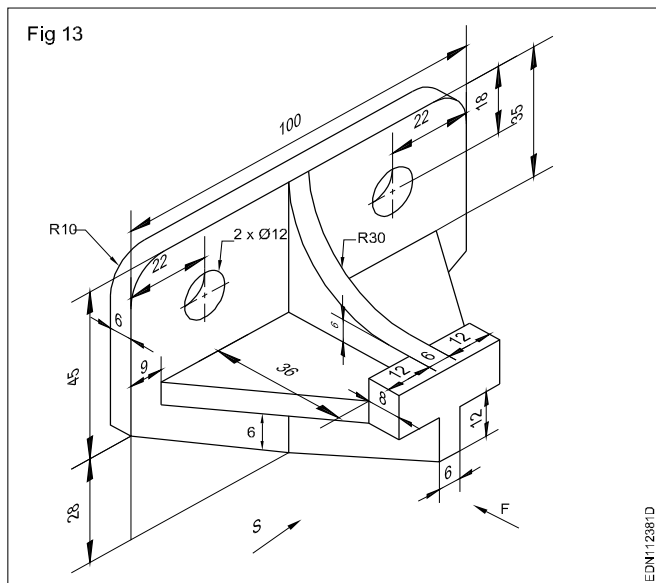

Draw three views of the given block in 3<sup>rd</sup> angle projection.

Draw three views of the given block in 1<sup>st</sup> angle projection.

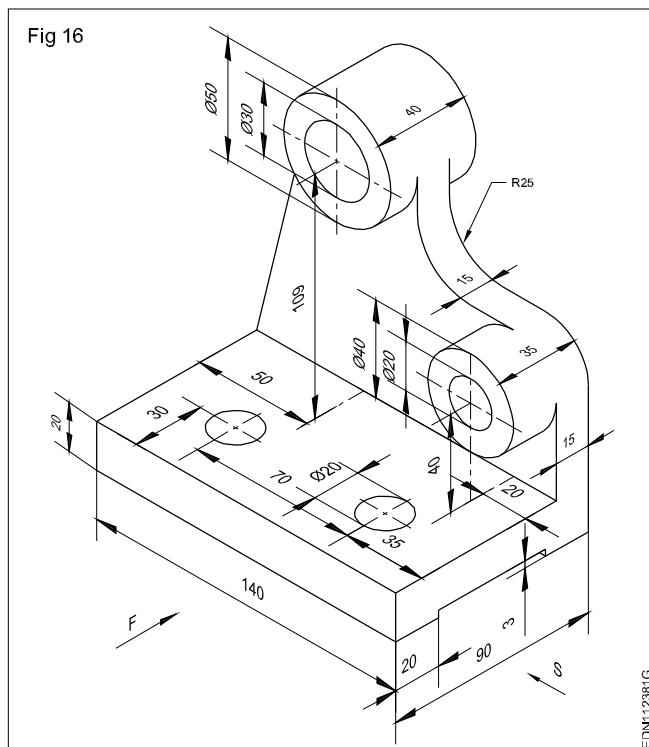

Draw three views of the given block in 1<sup>st</sup> angle projection.

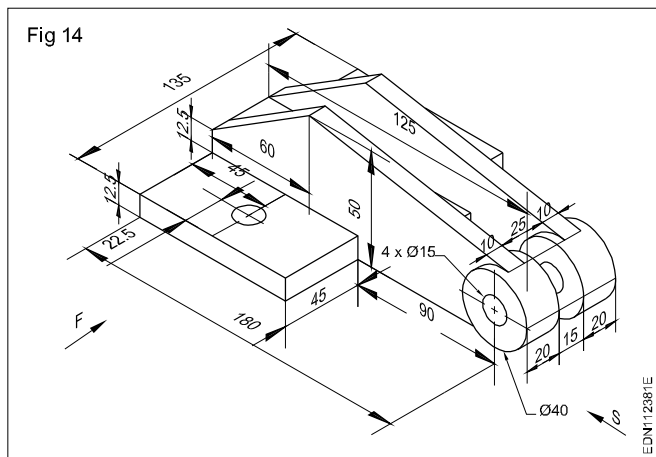

Draw three views of the given block in 3<sup>rd</sup> angle projection.

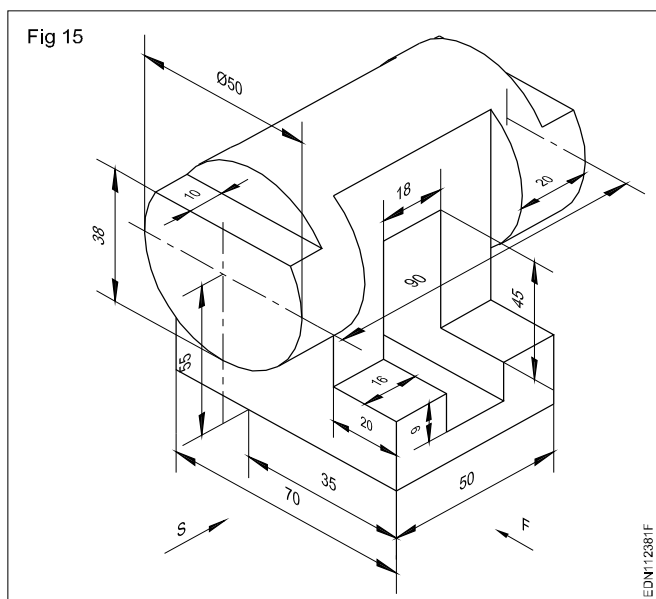
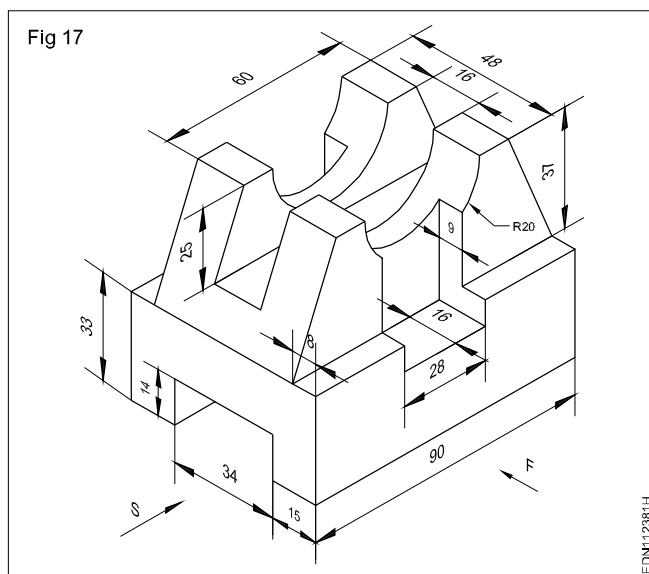

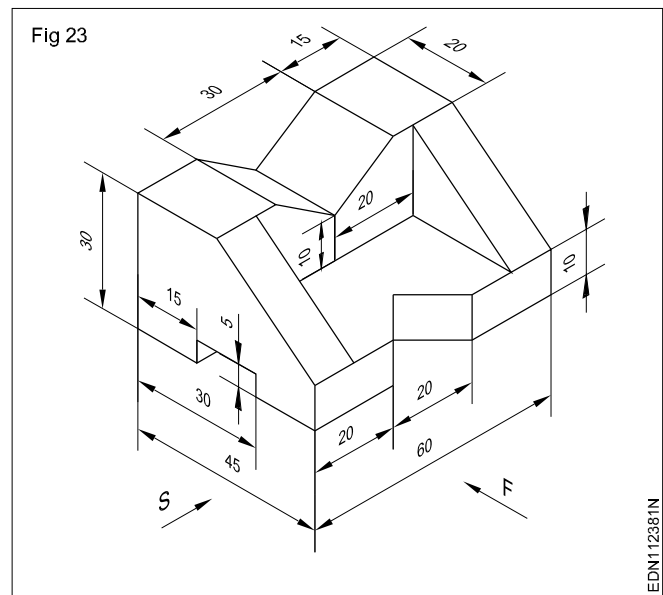
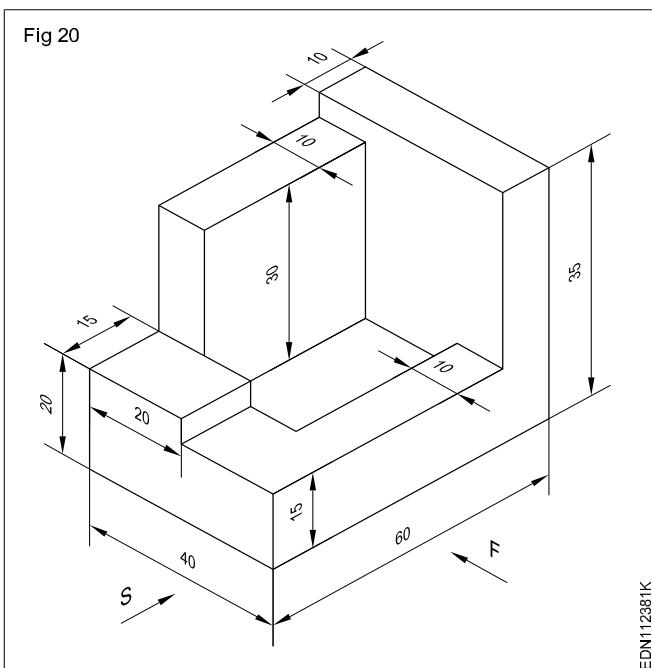
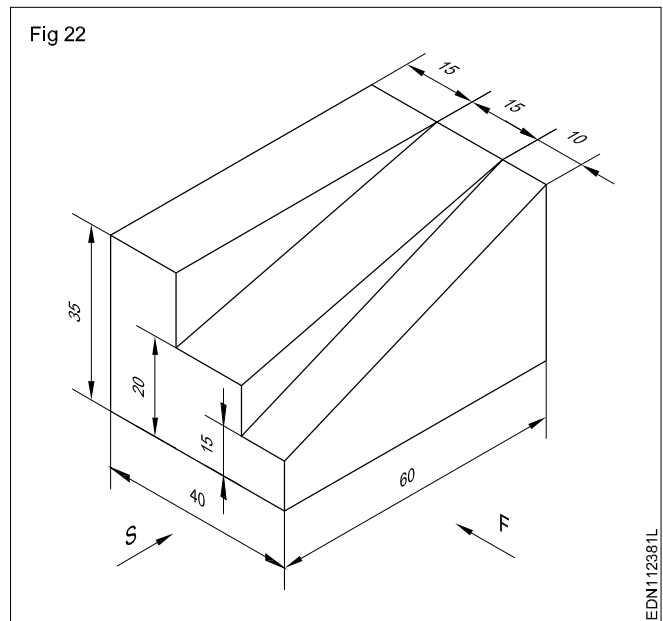
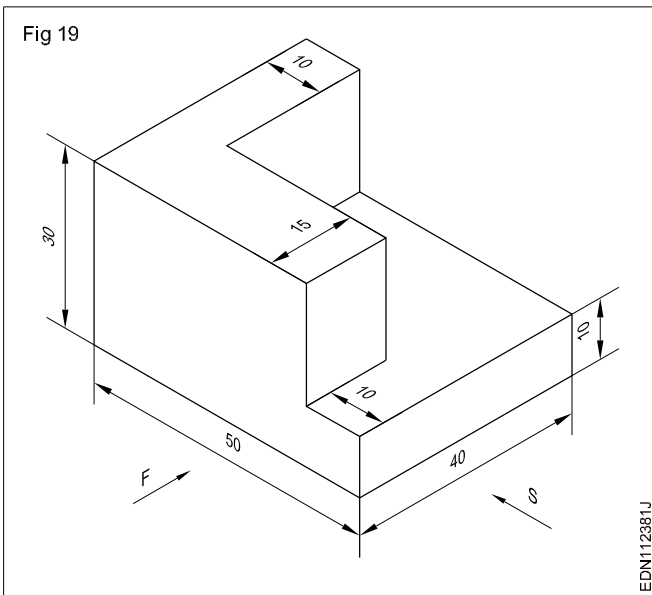
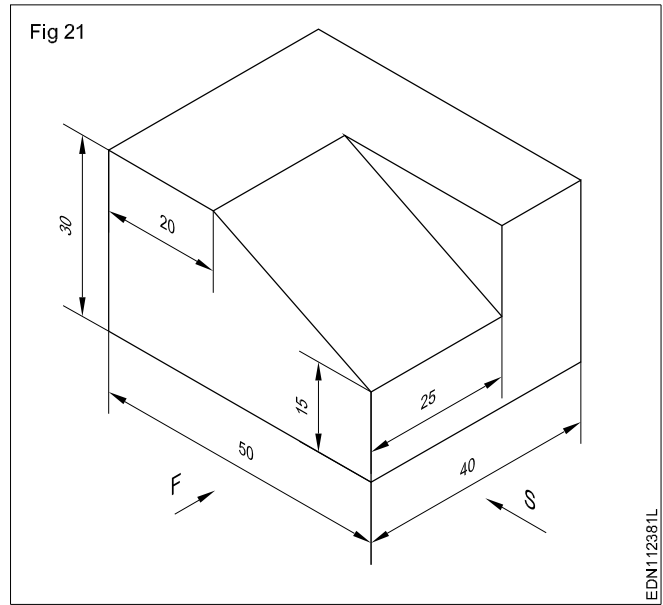
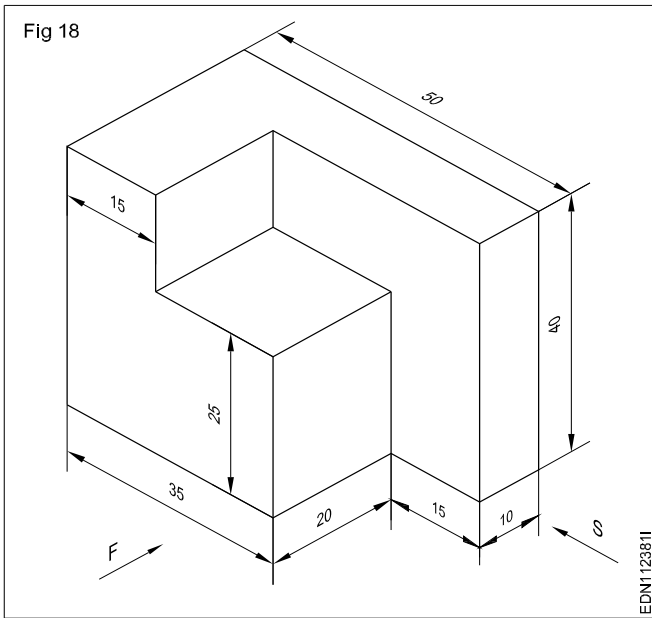

Reading of fabrication drawing for sheet metal worker trade

Funnel

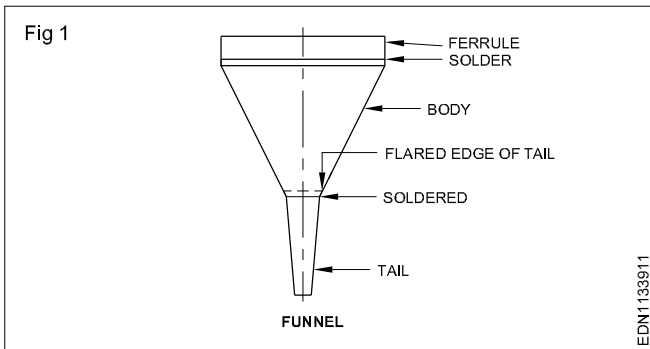

EDN1133911

Wire ring on the flange

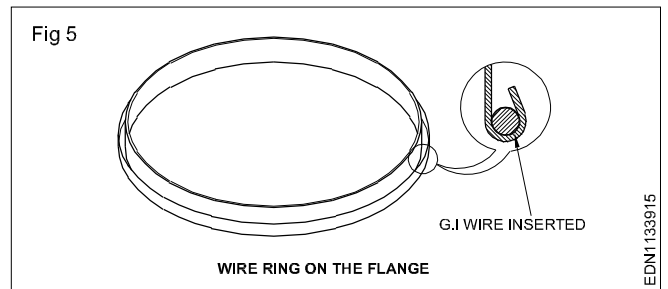

EDN1133915

Curved edge to be fixed using a gauge

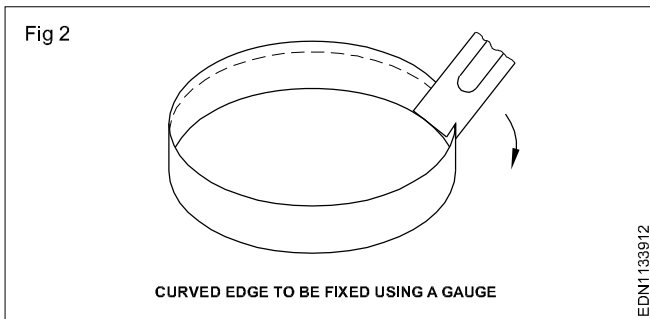

EDN1133912

Cylindrical shape by a round mandrel

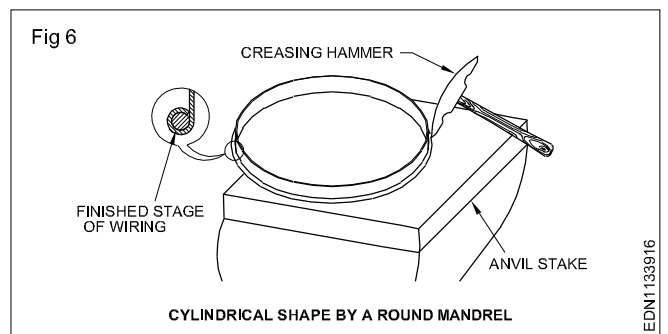

EDN1133916

Upset the flange

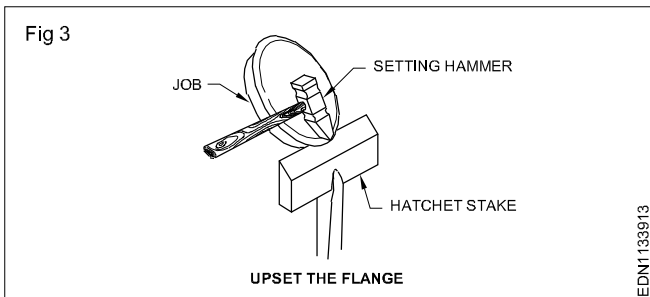

EDN1133913

Shoulder with ferrule

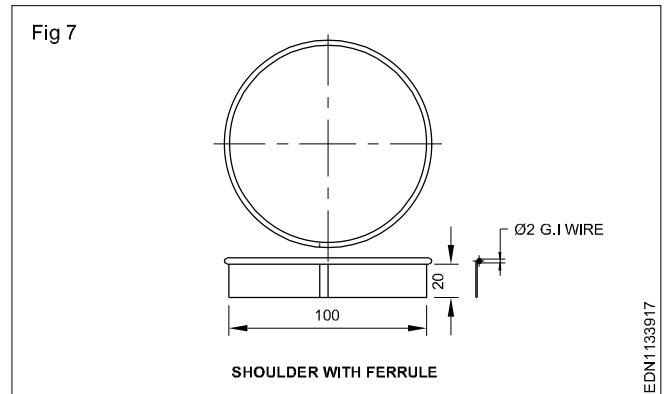

EDN1133917

Curve on the flange for wiring

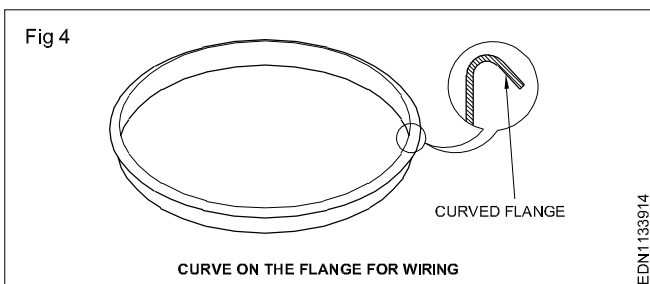

EDN1133914

Body

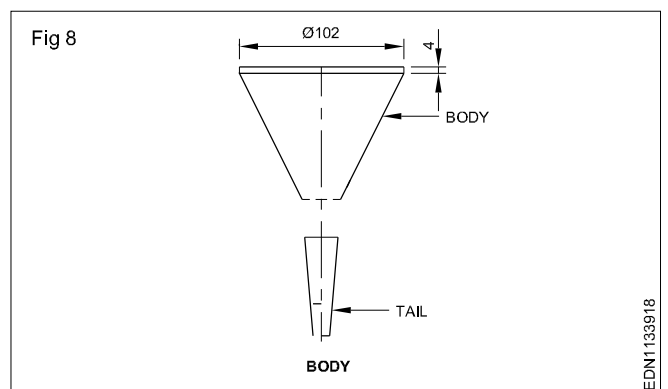

EDN1133918

## Handle

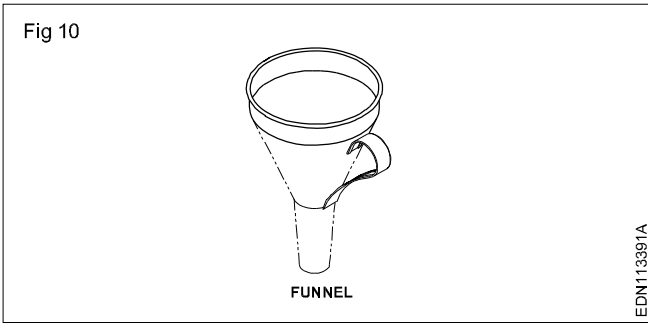

## Funnel

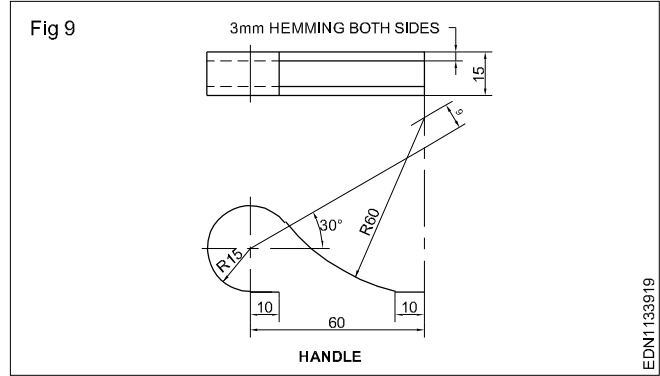

## Reading of fabrication drawing for welder trade

### Basic welding positions

- Flat or down hand position (Fig 1)

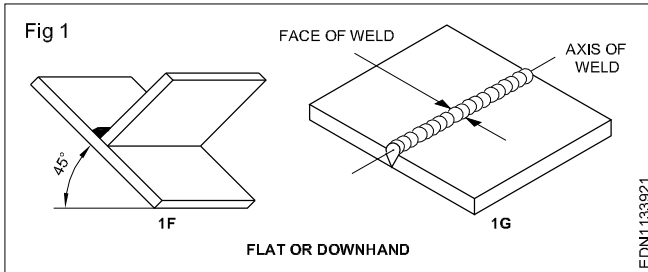

- Horizontal position (Fig 2)

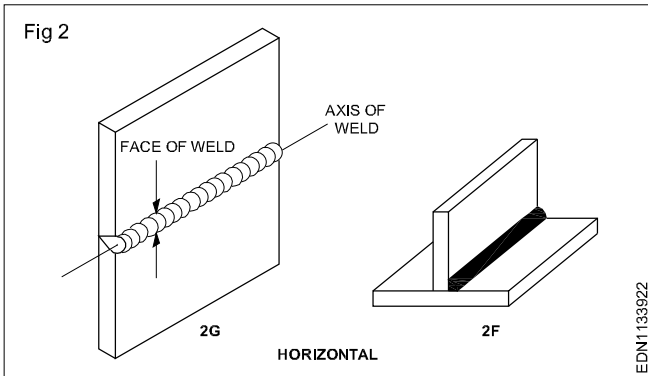

- Vertical position (Vertical up and down) (Fig 3)

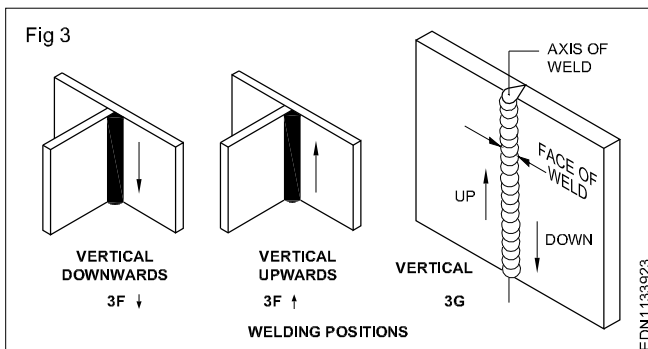

- Overhead position (Fig 4)

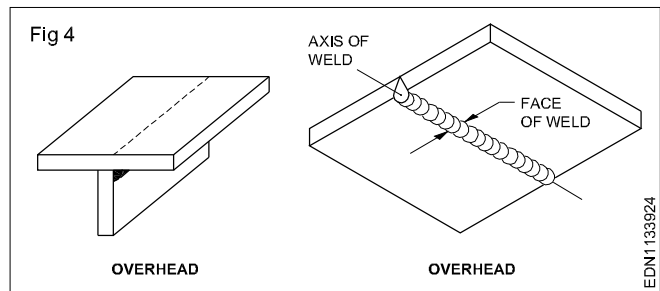

All welding action takes place in the molten pool, formed in the welding joint/welding line.

The position of the welding joint line and the weld face in respect of ground axis indicates the welding position.

All joints may be welded in all positions.

### Plate welding Position:

Welding Position	EN		ASME	
	Groove	Fillet	Groove	Fillet
Flat	PA	PA	1G	1F
Horizontal	PC	PB	2G	2F
Vertical	PG/PF	PG/PF	3G	3F
Overhead	PE	PD	4G	4F

### Pipe welding Position:

Welding Position	EN	ASME
	Groove	Groove
Flat	PA	1G
Horizontal	PC	2G
Multiple position	PF/PG	5G
Inclined (All position)	H-LO45	6G

# Reading of fabrication drawing for carpenter trade

Panel door (Fig 1)

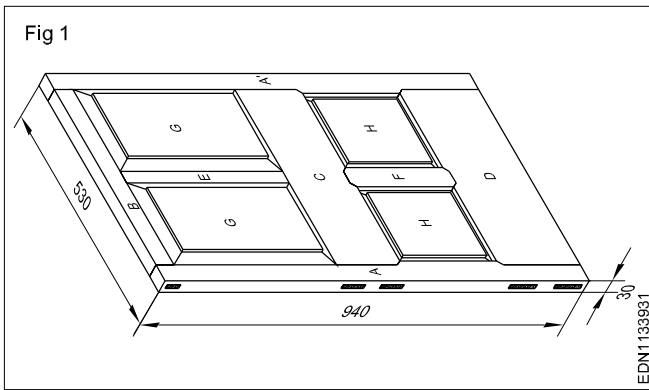

Window frame (Fig 3)

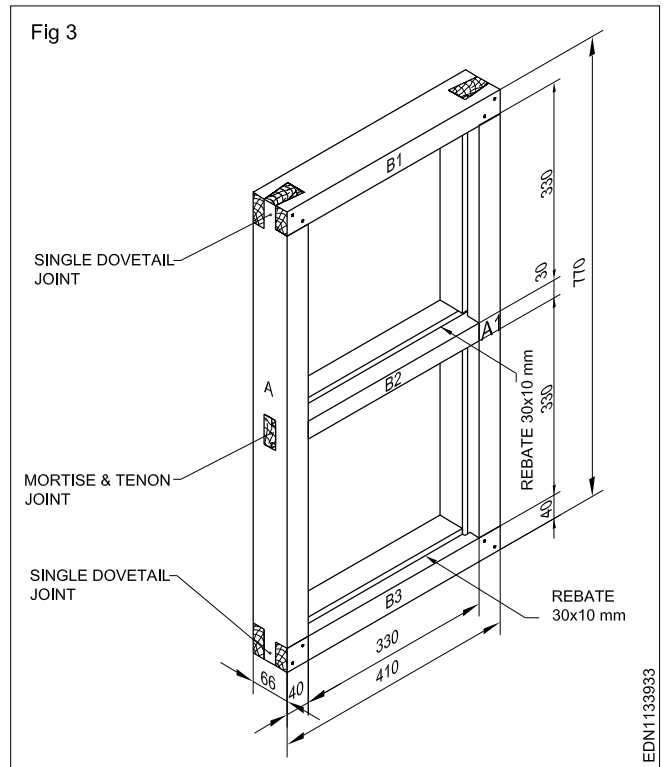

Parts of panel door (Fig 2)

